



*An Online PDH Course
brought to you by
CEDengineering.com*

Fundamentals of Aerodynamics - Part 2

Course No: M06-043

Credit: 6 PDH

Elie Tawil, P.E., LEED AP



Continuing Education and Development, Inc.

P: (877) 322-5800

info@cedengineering.com

This course was adapted from the Naval Aviation Schools Command, Publication No. CIN Q-9B-0020L CH1, “Fundamentals of Aerodynamics” – Training Guide, which is in the public domain.

Note: This course is based on sections Performance and Maneuvering, Spins, and Wake Turbulence and Wind Shear (pages 80 to 166) of this PDF document.

OUTLINE SHEET 2-1-1

BASIC THEORY

A. INTRODUCTION

This lesson is a basic introduction to the theory of aerodynamics. It provides a knowledge base in aerodynamic mathematics, air properties, airspeed and altitude definitions and measurements, airfoil and wing design, and the importance of center of gravity (CG).

B. ENABLING OBJECTIVES

- 2.1 DEFINE scalar, in a classroom, in accordance with Naval Aviation Fundamentals, NAVAVSCOLSCOM-SG-200
- 2.2 DEFINE vector, in a classroom, in accordance with Naval Aviation Fundamentals, NAVAVSCOLSCOM-SG-200
- 2.3 DEFINE mass, in a classroom, in accordance with Naval Aviation Fundamentals, NAVAVSCOLSCOM-SG-200
- 2.4 DEFINE volume, in a classroom, in accordance with Naval Aviation Fundamentals, NAVAVSCOLSCOM-SG-200
- 2.5 DEFINE density, in a classroom, in accordance with Naval Aviation Fundamentals, NAVAVSCOLSCOM-SG-200
- 2.6 DEFINE force, in a classroom, in accordance with Naval Aviation Fundamentals, NAVAVSCOLSCOM-SG-200
- 2.7 DEFINE weight, in a classroom, in accordance with Naval Aviation Fundamentals, NAVAVSCOLSCOM-SG-200
- 2.8 DEFINE moment, in a classroom, in accordance with Naval Aviation Fundamentals, NAVAVSCOLSCOM-SG-200
- 2.9 DEFINE work, in a classroom, in accordance with Naval Aviation Fundamentals, NAVAVSCOLSCOM-SG-200
- 2.10 DEFINE power, in a classroom, in accordance with Naval Aviation Fundamentals, NAVAVSCOLSCOM-SG-200

- 2.11 DEFINE energy, in a classroom, in accordance with Naval Aviation Fundamentals, NAVAVSCOLSCOM-SG-200
- 2.12 DEFINE potential energy, in a classroom, in accordance with Naval Aviation Fundamentals, NAVAVSCOLSCOM-SG-200
- 2.13 DEFINE kinetic energy, in a classroom, in accordance with Naval Aviation Fundamentals, NAVAVSCOLSCOM-SG-200
- 2.14 EXPLAIN Newton's Law of Equilibrium, in a classroom, in accordance with Naval Aviation Fundamentals, NAVAVSCOLSCOM-SG-200
- 2.15 STATE the requirements for an airplane to be in equilibrium flight, in a classroom, in accordance with Naval Aviation Fundamentals, NAVAVSCOLSCOM-SG-200
- 2.16 STATE the requirements for an airplane to be in trimmed flight, in a classroom, in accordance with Naval Aviation Fundamentals, NAVAVSCOLSCOM-SG-200
- 2.17 EXPLAIN Newton's Law of Acceleration, in a classroom, in accordance with Naval Aviation Fundamentals, NAVAVSCOLSCOM-SG-200
- 2.18 EXPLAIN Newton's Law of Interaction, in a classroom, in accordance with Naval Aviation Fundamentals, NAVAVSCOLSCOM-SG-200
- 2.19 DEFINE static pressure, in a classroom, in accordance with Naval Aviation Fundamentals, NAVAVSCOLSCOM-SG-200
- 2.20 DEFINE air density, in a classroom, in accordance with Naval Aviation Fundamentals, NAVAVSCOLSCOM-SG-200
- 2.21 DEFINE temperature, in a classroom, in accordance with Naval Aviation Fundamentals, NAVAVSCOLSCOM-SG-200
- 2.22 DEFINE lapse rate, in a classroom, in accordance with Naval Aviation Fundamentals, NAVAVSCOLSCOM-SG-200
- 2.23 DEFINE humidity, in a classroom, in accordance with Naval Aviation Fundamentals, NAVAVSCOLSCOM-SG-200
- 2.24 DESCRIBE the relationship between humidity and air density, in a classroom, in accordance with Naval Aviation Fundamentals, NAVAVSCOLSCOM-SG-200
- 2.25 DEFINE viscosity, in a classroom, in accordance with Naval Aviation Fundamentals, NAVAVSCOLSCOM-SG-200

- 2.26 DESCRIBE the relationship between temperature and viscosity, in a classroom, in accordance with Naval Aviation Fundamentals, NAVAVSCOLSCOM-SG-200
- 2.27 DEFINE local speed of sound, in a classroom, in accordance with Naval Aviation Fundamentals, NAVAVSCOLSCOM-SG-200
- 2.28 DESCRIBE the relationship between temperature and local speed of sound, in a classroom, in accordance with Naval Aviation Fundamentals, NAVAVSCOLSCOM-SG-200
- 2.29 STATE the values for standard atmosphere, in a classroom, in accordance with Naval Aviation Fundamentals, NAVAVSCOLSCOM-SG-200
- 2.30 DESCRIBE the General Gas Law, given static pressure, air density, temperature, and altitude, in a classroom, in accordance with Naval Aviation Fundamentals, NAVAVSCOLSCOM-SG-200
- 2.31 EXPLAIN Bernoulli's Equation, given dynamic pressure, static pressure, and total pressure, in a classroom, in accordance with Naval Aviation Fundamentals, NAVAVSCOLSCOM-SG-200
- 2.32 DEFINE steady airflow, in a classroom, in accordance with Naval Aviation Fundamentals, NAVAVSCOLSCOM-SG-200
- 2.33 DEFINE streamline, in a classroom, in accordance with Naval Aviation Fundamentals, NAVAVSCOLSCOM-SG-200
- 2.34 DEFINE streamtube, in a classroom, in accordance with Naval Aviation Fundamentals, NAVAVSCOLSCOM-SG-200
- 2.35 EXPLAIN the continuity equation given density, cross-sectional area, and velocity, in a classroom, in accordance with Naval Aviation Fundamentals, NAVAVSCOLSCOM-SG-200
- 2.36 DEFINE indicated altitude, in a classroom, in accordance with Naval Aviation Fundamentals, NAVAVSCOLSCOM-SG-200
- 2.37 DEFINE Above Ground Level (AGL) altitude, in a classroom, in accordance with Naval Aviation Fundamentals, NAVAVSCOLSCOM-SG-200
- 2.38 DEFINE Mean Sea Level (MSL) altitude, in a classroom, in accordance with Naval Aviation Fundamentals, NAVAVSCOLSCOM-SG-200

- 2.39 DEFINE pressure altitude, in a classroom, in accordance with Naval Aviation Fundamentals, NAVAVSCOLSCOM-SG-200
- 2.40 DEFINE density altitude, in a classroom, in accordance with Naval Aviation Fundamentals, NAVAVSCOLSCOM-SG-200
- 2.41 DESCRIBE the pitot-static system given the system components and Bernoulli's equation, in a classroom, in accordance with Naval Aviation Fundamentals, NAVAVSCOLSCOM-SG-200
- 2.42 DEFINE indicated airspeed, in a classroom, in accordance with Naval Aviation Fundamentals, NAVAVSCOLSCOM-SG-200
- 2.43 DEFINE calibrated airspeed, in a classroom, in accordance with Naval Aviation Fundamentals, NAVAVSCOLSCOM-SG-200
- 2.44 DEFINE equivalent airspeed, in a classroom, in accordance with Naval Aviation Fundamentals, NAVAVSCOLSCOM-SG-200
- 2.45 DEFINE true airspeed, in a classroom, in accordance with Naval Aviation Fundamentals, NAVAVSCOLSCOM-SG-200
- 2.46 DEFINE ground speed, in a classroom, in accordance with Naval Aviation Fundamentals, NAVAVSCOLSCOM-SG-200
- 2.47 DESCRIBE the factors affecting the different types of airspeed, in a classroom, in accordance with Naval Aviation Fundamentals, NAVAVSCOLSCOM-SG-200
- 2.48 DEFINE an aircraft, in a classroom, in accordance with Naval Aviation Fundamentals, NAVAVSCOLSCOM-SG-200
- 2.49 DEFINE an airplane, in a classroom, in accordance with Naval Aviation Fundamentals, NAVAVSCOLSCOM-SG-200
- 2.50 DESCRIBE the five components of an airplane, in a classroom, in accordance with Naval Aviation Fundamentals, NAVAVSCOLSCOM-SG-200
- 2.51 STATE the advantages of the semi-monocoque fuselage construction, in a classroom, in accordance with Naval Aviation Fundamentals, NAVAVSCOLSCOM-SG-200
- 2.52 DEFINE full cantilever wing construction, in a classroom, in accordance with Naval Aviation Fundamentals, NAVAVSCOLSCOM-SG-200

- 2.53 DESCRIBE the airplane three-axis reference system, in a classroom, in accordance with Naval Aviation Fundamentals, NAVAVSCOLSCOM-SG-200
- 2.54 DEFINE chord line, in a classroom, in accordance with Naval Aviation Fundamentals, NAVAVSCOLSCOM-SG-200
- 2.55 DEFINE chord, in a classroom, in accordance with Naval Aviation Fundamentals, NAVAVSCOLSCOM-SG-200
- 2.56 DEFINE root chord, in a classroom, in accordance with Naval Aviation Fundamentals, NAVAVSCOLSCOM-SG-200
- 2.57 DEFINE tip chord, in a classroom, in accordance with Naval Aviation Fundamentals, NAVAVSCOLSCOM-SG-200
- 2.58 DEFINE average chord, in a classroom, in accordance with Naval Aviation Fundamentals, NAVAVSCOLSCOM-SG-200
- 2.59 DEFINE mean camber line, in a classroom, in accordance with Naval Aviation Fundamentals, NAVAVSCOLSCOM-SG-200
- 2.60 DEFINE symmetric airfoil, in a classroom, in accordance with Naval Aviation Fundamentals, NAVAVSCOLSCOM-SG-200
- 2.61 DEFINE positive camber, in a classroom, in accordance with Naval Aviation Fundamentals, NAVAVSCOLSCOM-SG-200
- 2.62 DEFINE negative camber, in a classroom, in accordance with Naval Aviation Fundamentals, NAVAVSCOLSCOM-SG-200
- 2.63 DEFINE spanwise flow, in a classroom, in accordance with Naval Aviation Fundamentals, NAVAVSCOLSCOM-SG-200
- 2.64 DEFINE chordwise flow, in a classroom, in accordance with Naval Aviation Fundamentals, NAVAVSCOLSCOM-SG-200
- 2.65 DEFINE pitch attitude, in a classroom, in accordance with Naval Aviation Fundamentals, NAVAVSCOLSCOM-SG-200
- 2.66 DEFINE flight path, in a classroom, in accordance with Naval Aviation Fundamentals, NAVAVSCOLSCOM-SG-200
- 2.67 DEFINE relative wind, in a classroom, in accordance with Naval Aviation Fundamentals, NAVAVSCOLSCOM-SG-200

- 2.68 DEFINE angle of attack, in a classroom, in accordance with Naval Aviation Fundamentals, NAVAVSCOLSCOM-SG-200
- 2.69 DEFINE angle of incidence, in a classroom, in accordance with Naval Aviation Fundamentals, NAVAVSCOLSCOM-SG-200
- 2.70 DEFINE dihedral angle, in a classroom, in accordance with Naval Aviation Fundamentals, NAVAVSCOLSCOM-SG-200
- 2.71 DEFINE wingspan, in a classroom, in accordance with Naval Aviation Fundamentals, NAVAVSCOLSCOM-SG-200
- 2.72 DEFINE wing area, in a classroom, in accordance with Naval Aviation Fundamentals, NAVAVSCOLSCOM-SG-200
- 2.73 DEFINE wing loading, in a classroom, in accordance with Naval Aviation Fundamentals, NAVAVSCOLSCOM-SG-200
- 2.74 DEFINE taper ratio, in a classroom, in accordance with Naval Aviation Fundamentals, NAVAVSCOLSCOM-SG-200
- 2.75 DEFINE sweep angle, in a classroom, in accordance with Naval Aviation Fundamentals, NAVAVSCOLSCOM-SG-200
- 2.76 DEFINE aspect ratio, in a classroom, in accordance with Naval Aviation Fundamentals, NAVAVSCOLSCOM-SG-200
- 2.77 DEFINE the center of gravity, in a classroom, in accordance with Naval Aviation Fundamentals, NAVAVSCOLSCOM-SG-200
- 2.78 DEFINE the aerodynamic center, in a classroom, in accordance with Naval Aviation Fundamentals, NAVAVSCOLSCOM-SG-200
- 2.79 DESCRIBE the motions that occur around the airplane center of gravity, in a classroom, in accordance with Naval Aviation Fundamentals, NAVAVSCOLSCOM-SG-200

C. TOPIC OUTLINE

1. Introduction
2. This Lesson Topic
3. Basics
4. Atmospheric Properties
5. Properties of Airflow
6. Altitude Measurement
7. Airspeed Measurement
8. Major Components of an Airplane
9. Airfoils and Wing Properties
10. Center of Gravity (CG)
11. Summary and Review
12. Application
13. Assignment

INFORMATION SHEET 2-1-2

BASIC THEORY

A. INTRODUCTION

This lesson is a basic introduction to the theory of aerodynamics. It provides a knowledge base in aerodynamic mathematics, air properties, airspeed and altitude definitions and measurements, airfoil and wing design, and the importance of center of gravity (CG).

B. REFERENCES

1. Aerodynamics for Naval Aviators, NAVAIR 00-80T-80
2. Introduction to the Aerodynamics of Flight, NASA SP-367
3. Publication, U.S. Standard Atmosphere, 1976, NOAA-S/T 76-1562
4. T-6 Joint Primary Pilot Training, AETC / CNATRA Syllabus P-V4A-J NATOPS Flight Manual

C. INFORMATION

MATHEMATICAL SYSTEMS

A **scalar** is a quantity that represents only magnitude, e.g., time, temperature, or volume. It is expressed using a single number, including any units. A **vector** is a quantity that represents magnitude and direction. It is commonly used to represent displacement, velocity, acceleration, or force. **Displacement (s)** is the distance and direction of a body's movement (an airplane flies east 100 nm). **Velocity (V)** is the speed and direction of a body's motion, the rate of change of position (an airplane flies south at 400 knots). **Speed** is a scalar equal to the magnitude of the velocity vector. **Acceleration (a)** is the rate and direction of a body's change of velocity (gravity accelerates bodies toward the center of the earth at 32.174 ft/s²). A **force (F)** is a push or pull exerted on a body (1,000 lbs of thrust pushes a jet through the sky).

A vector may be represented graphically by an arrow. The length of the arrow represents the magnitude and the heading of the arrow represents the direction. Vectors may be added by placing the head of the first vector on the tail of the second and drawing a third vector from the tail of the first to the head of the second. This new vector (Figure 1-1) is the resulting magnitude and direction of the original two vectors working together.

DEFINITIONS

Mass (m) is the quantity of molecular material that comprises an object.

Volume (v) is the amount of space occupied by an object.

Density (ρ) is mass per unit volume. It is expressed:

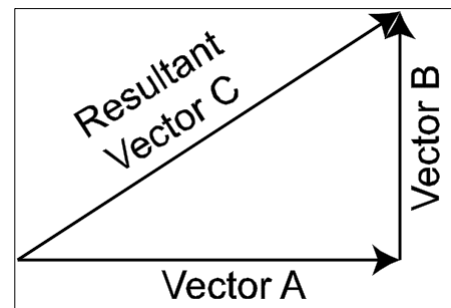

Figure 1-1 Vector Addition

$$\rho = \text{mass} / \text{volume}$$

Weight (W) is the force with which a mass is attracted toward the center of the earth by gravity.

Force (F) is mass times acceleration:

$$F = m \times a$$

A **moment (M)** is created when a force is applied at some distance from an axis or fulcrum, and tends to produce rotation about that point. A moment is a vector quantity equal to a force (F) times the distance (d) from the point of rotation that is perpendicular to the force (Figure 1-2). This perpendicular distance is called the moment arm.

Work (W) is done when a force acts on a body and moves it. It is a scalar quantity equal to the force (F) times the distance of displacement (s).

$$W = F \times s$$

Power (P) is the rate of doing work or work done per unit of time.

$$P = W / t$$

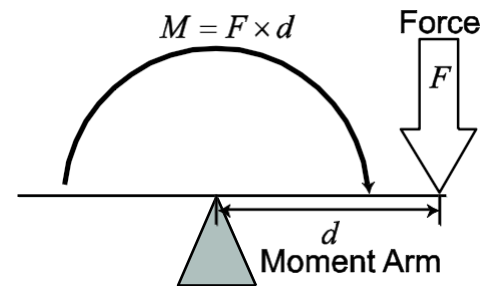

Figure 1-2 Moment

Energy is a scalar measure of a body's capacity to do work. There are two types of energy: potential energy and kinetic energy. Energy cannot be created or destroyed, but may be transformed from one form to another. This principle is called conservation of energy. The equation for total energy is:

$$TE = PE + KE$$

Potential energy (PE) is the ability of a body to do work because of its position or state of being. It is a function of mass (m), gravity (g), and height (h):

$$PE = \text{weight} \times \text{height} = mgh$$

Kinetic energy (KE) is the ability of a body to do work because of its motion. It is a function of mass (m) and velocity (V):

$$KE = \frac{1}{2} mV^2$$

Work may be performed on a body to change its position and give it potential energy or work may give the body motion so that it has kinetic energy. Under ideal conditions, potential energy may be completely converted to kinetic energy, and vice versa. The kinetic energy of a glider in forward flight is converted into potential energy in a climb. As the glider's velocity (KE) diminishes, its altitude (PE) increases.

NEWTON'S LAWS OF MOTION

NEWTON'S FIRST LAW - THE LAW OF EQUILIBRIUM

"A body at rest tends to remain at rest and a body in motion tends to remain in motion in a straight line at a constant velocity unless acted upon by some unbalanced force."

The tendency of a body to remain in its condition of rest or motion is called inertia. **Equilibrium** is the absence of acceleration, either linear or angular. **Equilibrium flight** exists when the sum of all forces and the sum of all moments around the center of gravity are equal to zero. An airplane in straight and level flight at a constant velocity is acted upon by four forces: thrust, drag, lift and weight. When these forces exactly cancel each other out, the airplane is in equilibrium (Figure 1-3).

Trimmed flight exists when the sum of all moments around the center of gravity is equal to zero. In trimmed flight, the sum of the forces may not be equal to zero. For example, an airplane in a constant rate, constant angle of bank turn is in trimmed, but not equilibrium, flight. An airplane in equilibrium flight, however, is always in trimmed flight.

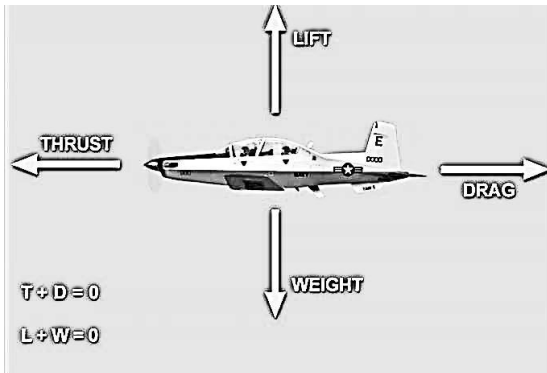

Figure 1-3 Equilibrium Level Flight

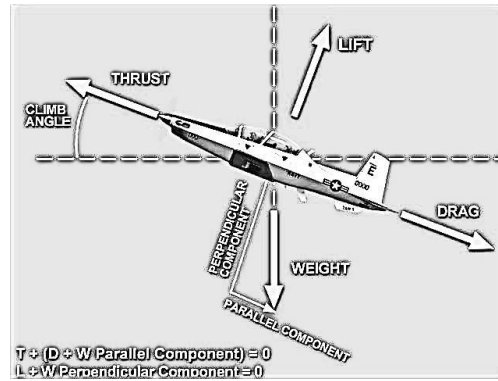

Figure 1-4 Equilibrium Climbing Flight

An airplane does not have to be in straight and level flight to be in equilibrium. Figure 1-4 shows an airplane that is climbing, but not accelerating or decelerating, i.e., there are no unbalanced forces. It is another example of equilibrium flight. Thrust must overcome drag plus the parallel component of weight. Lift must overcome the perpendicular component of weight.

An airplane with sufficient thrust to climb vertically at a constant true airspeed can achieve an equilibrium vertical flight condition. Thrust must equal weight plus total drag, and lift must be zero (Figure 1-5).

NEWTON'S SECOND LAW - THE LAW OF ACCELERATION

“An unbalanced force (F) acting on a body produces an acceleration (a) in the direction of the force that is directly proportional to the force and inversely proportional to the mass (m) of the body.”

In equation form:

$$a = \frac{F}{m} \quad a = \frac{V_{out} - V_{in}}{time}$$

When an airplane's thrust is greater than its drag (in level flight), the excess thrust will accelerate the airplane until drag increases to equal thrust.

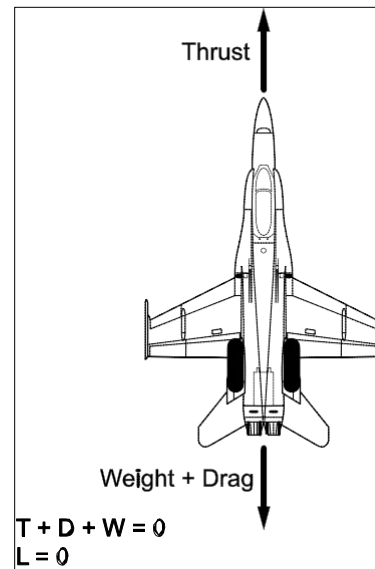

Figure 1-5 Equilibrium Vertical Flight

NEWTON'S THIRD LAW - THE LAW OF INTERACTION

“For every action, there is an equal and opposite reaction; the forces of two bodies on each other are always equal and are directed in opposite directions.”

This law is demonstrated when the rearward force from an aircraft propeller's propwash causes an aircraft to thrust forward at an equal amount of force (Figure 1-6).

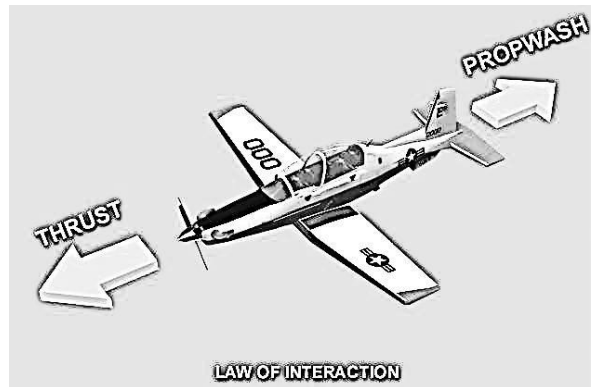

Figure 1-6 Action and Reaction

PROPERTIES OF THE ATMOSPHERE

The atmosphere is composed of approximately 78% nitrogen, 21% oxygen, and 1% other gases, including argon and carbon dioxide. Air is considered to be a uniform mixture of these gases, so we will examine its characteristics as a whole rather than as separate gases.

Static pressure (P_s) is the pressure particles of air exert on adjacent bodies. Ambient static pressure is equal to the weight of a column of air over a given area. The force of static pressure always acts perpendicular to any surface that the air particles collide with, regardless of whether the air is moving with respect to that surface.

As altitude increases, there is less air in the column above, so it weighs less. Thus atmospheric static pressure decreases with an increase in altitude. At low altitudes, it decreases at a rate of approximately 1.0 in. Hg per 1000 ft.

Air density (ρ) is the total mass of air particles per unit of volume. The distance between individual air particles increases with altitude resulting in fewer particles per unit volume. Therefore, air density decreases with an increase in altitude.

Air consists of very many individual particles, each moving randomly with respect to the others. **Temperature (T)** is a measure of the average random kinetic energy of air particles. Air temperature decreases linearly with an increase in altitude at a rate of 2 °C (3.57 °F) per 1000 ft until approximately 36,000 feet. This rate of temperature change is called the **average lapse rate**. From 36,000 feet through approximately 66,000 feet, the air remains at a constant -56.5 °C (-69.7 °F). This layer of constant temperature is called the **isothermal layer**.

Humidity is the amount of water vapor in the air. As humidity increases, water molecules displace an equal number of air molecules. Since water molecules have less mass and do not change the number of particles per unit volume of air, density decreases. Therefore, as humidity increases, air density decreases.

Viscosity (μ) is a measure of the air's resistance to flow and shearing. Air viscosity can be demonstrated by its tendency to stick to a surface. For liquids, as temperature increases, viscosity decreases. Recall that the oil in a

car gets thinner when the engine gets hot. Just the opposite happens with air: Air viscosity increases with an increase in temperature.

Sound is caused by disturbances of the air that causes a sudden compression or vibration. This creates a series of alternating compressions and rarefactions which is transmitted to our ears as sound. The compressions and rarefactions are transmitted from one particle to another, but particles do not flow from one point to another. Sound is wave motion, not particle motion. The **local speed of sound** is the rate at which sound waves travel through a particular air mass. The speed of sound, in air, is dependent only on the temperature of the air. The warmer the air, the more excited the particles are in that air mass. The more excited the molecules are, the more easily adjacent molecules can propagate a sound wave. As the temperature of air increases, the speed of sound increases.

THE STANDARD ATMOSPHERE

The atmospheric layer in which most flying is done is an ever-changing environment. Temperature and pressure vary with altitude, season, location, time, and even sunspot activity. It is impractical to take all of these into consideration when discussing airplane performance. In order to disregard these atmospheric changes, an engineering baseline has been developed called the **standard atmosphere**. It is a set of reference conditions giving representative values of air properties as a function of altitude. A summary may be found in Appendix C. Although it is rare to encounter weather conditions that match the standard atmosphere, it is nonetheless representative of average zero humidity conditions at middle latitudes. Unless otherwise stated, any discussion of atmospheric properties in this course will assume standard atmospheric conditions.

	English	Metric (SI)
Static Pressure P_{s0}	29.92 in. Hg	1013.25 mbar
Temperature T_0	59 °F	15 °C
Average Lapse Rate	3.57 °F / 1000 ft	2 °C / 1000 ft
ρ_0	.0024 slugs / ft ³	1.225 g / l
Local Speed of Sound	661.7 knots	340.4 m / s

Table 1-1 Sea Level Standard Atmospheric Conditions

THE GENERAL GAS LAW

The General Gas Law sets the relationship between three properties of air: pressure (P), density (ρ), and temperature (T). It is expressed as an equation where R is a constant for any given gas (such as dry air):

$$P = \rho RT$$

One method to increase pressure is to keep density constant and increase temperature (as in a pressure cooker). If pressure remains constant, there is an inverse relationship between density and temperature. An increase in temperature must result in a decrease in density, and vice versa.

ALTITUDE MEASUREMENT

Altitude is defined as the geometric height above a given plane of reference. **True altitude** is the actual height above mean sea level. **Pressure altitude (PA)** is the height above the standard datum plane. The standard datum plane is the actual elevation at which the barometric pressure is 29.92 in. Hg. Since the standard datum plane is at sea level in the standard atmosphere, true altitude will be equal to pressure altitude.

Density altitude (DA) is the altitude in the standard atmosphere where the air density is equal to local air density. It is found by correcting pressure altitude for temperature and humidity deviations from the standard atmosphere. In the standard atmosphere, density altitude is equal to pressure altitude. But as temperature or humidity increase, the air becomes less dense, with the effect that the actual air density at one altitude is equal to that of a higher altitude on a standard day. A high DA indicates a low air density.

Density altitude is not used as a height reference, but as a predictor of aircraft performance. A high DA will decrease the power produced by an engine because less oxygen is available for combustion. It will also reduce the thrust produced by a propeller or jet engine because fewer air molecules are available to be accelerated. The reduced power and thrust will reduce an airplane's acceleration and climb performance. A high DA also requires a higher true airspeed for takeoff and landing and will therefore increase takeoff and landing distances.

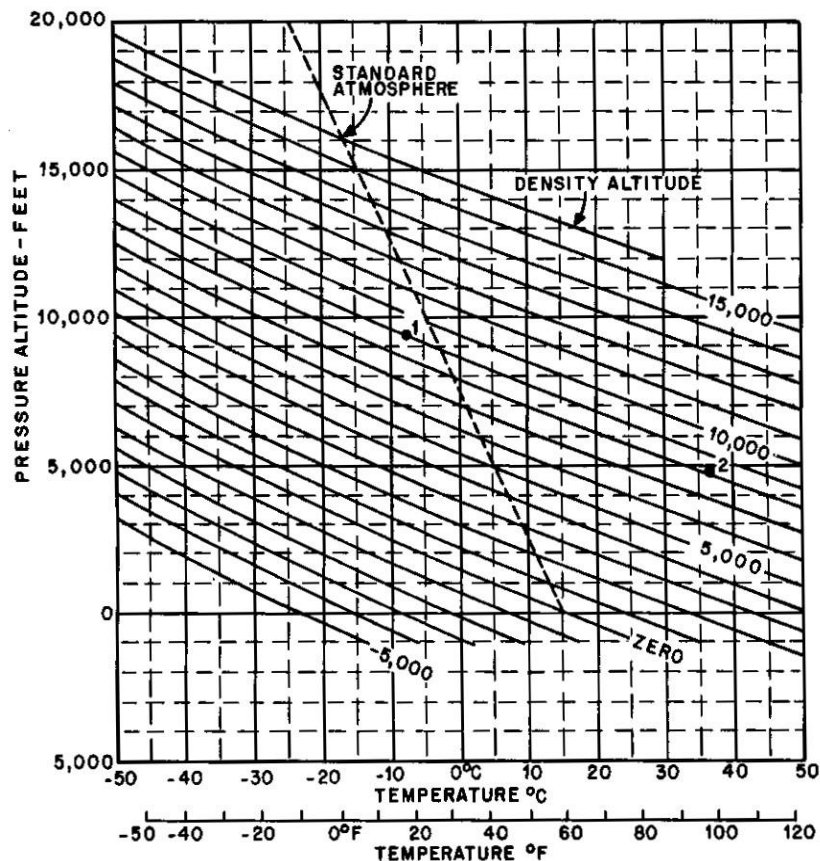

Figure 1-7 Density Altitude as a Function of Temperature and Pressure Altitude

Over a typical day, static pressure and pressure altitude remain virtually constant. However, as the sun heats the air, the reduced density causes a dramatic increase in density altitude. This will have a noticeable impact on aircraft performance. Figure 1-7 can be used to determine density altitude from pressure altitude and temperature (but does not take into account the effects of humidity).

Properties of Airflow

The atmosphere is a uniform mixture of gases with the properties of a fluid and subject to the laws of fluid motion. Fluids can flow and may be of a liquid or gaseous state. They yield easily to changes in static pressure, density, temperature and velocity. **Steady airflow** exists if at every point in the airflow static pressure, density, temperature and velocity remain constant over time. The speed and/or direction of the individual air particles may vary from one point to another in the flow, but the velocity of every particle that passes any given point is always the same. In steady airflow, a particle of air follows the same path as the preceding particle. A **streamline** is the path that air particles follow in steady airflow (Figure 1-8). In steady airflow, particles do not cross streamlines.

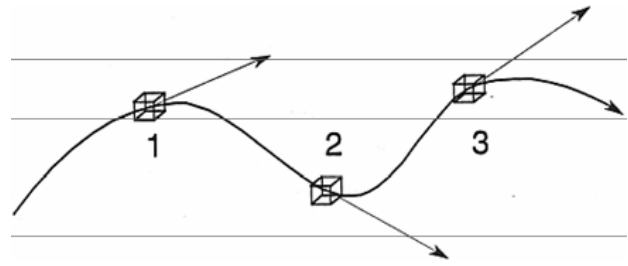

Figure 1-8 Streamline in Steady Airflow

A collection of many adjacent streamlines forms a **streamtube**, which contains a flow just as effectively as a tube with solid walls (Figure 1-9). In steady airflow, a streamtube is a closed system, in which mass and total energy must remain constant. If mass is added to the streamtube, an equal amount of mass will be removed. An analogy is a garden hose in which each unit of water that flows in displaces another that flows out. Energy cannot be added to or removed from the system, although it can be transformed from one form to another.

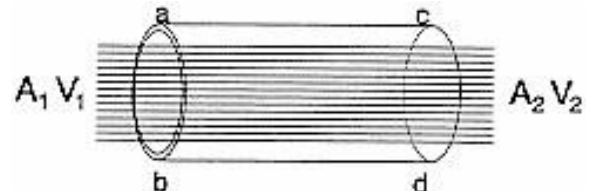

Figure 1-9 Streamtube

The Continuity Equation

Let us intersect the streamtube with two planes perpendicular to the airflow at points a-b and c-d, with cross-sectional areas of A_1 and A_2 , respectively (Figure 1-10). The amount of mass passing any point in the streamtube may be found by multiplying area by velocity to give volume/unit time and then multiplying by density to give mass/unit time. This is called mass flow rate (\dot{M}) and is expressed as:

$$\dot{M} = \rho AV$$

The amount of mass flowing through A_1 must equal that flowing through A_2 , since no mass can flow through the walls of the streamtube. Thus, an equation expressing the continuity of flow through a streamtube is:

$$\rho_1 A_1 V_1 = \rho_2 A_2 V_2$$

Our discussion is limited to subsonic airflow, so we can ignore changes in density due to compressibility. If we assume that both ends of the streamtube are at the same altitude, then ρ_1 is equal to ρ_2 and we can cancel them from our equation. The simplified, subsonic, continuity equation that we will use is:

$$A_1 V_1 = A_2 V_2$$

If the cross sectional area decreases on one side of the equation, the velocity must increase on the same side so both sides remain equal. Thus velocity and area in a streamtube are inversely related.

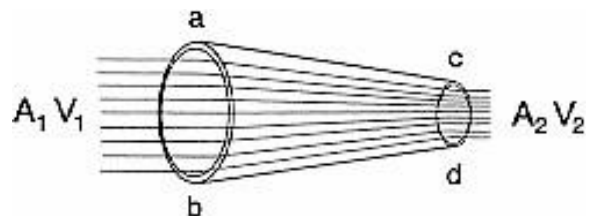

Figure 1-10 Continuity of Flow

Bernoulli's Equation

Daniel Bernoulli, a Swiss mathematician, described the variation of pressure exerted by a moving mass of fluid. His equation shows that the total energy of a fluid can be separated into potential energy (static pressure) and kinetic energy (dynamic pressure). Bernoulli's equation applies in a frictionless, incompressible airflow.

Static pressure (p_s) is the pressure particles of air exert on adjacent bodies. Ambient static pressure is equal to the weight of a column of air over a given area. The force of static pressure always acts perpendicular to any surface that the air particles collide with, regardless of whether the air is moving with respect to that surface.

Dynamic Pressure (q) is a measure of impact pressure of a large group of air molecules moving together. If a gas is static and not flowing, the measured pressure is the same in all directions. However, if the gas is flowing, the measured pressure depends on the direction of motion. It is expressed as:

$$q = \frac{1}{2} \rho V^2$$

Total Pressure (H) is the sum of static and dynamic pressure. For a closed system, total pressure is constant; therefore, an increase in static pressure results in a decrease in dynamic pressure, and vice versa. It is expressed as:

$$H = p_s + \frac{1}{2} \rho V^2$$

Where:

H = total pressure

p = static pressure

ρ = density

V = velocity

Substituting for dynamic pressure gives us Bernoulli's equation:

$$H = p_s + q$$

Airspeed Measurement

Airspeed is a necessary calculation for aircraft. Airspeed is critical for ensuring you have sufficient airflow over the wings for takeoff but not enough to cause structural damage, for navigation, for weapon employment and many other scenarios. However, unlike automobiles, aircraft cannot measure velocity, or dynamic pressure, directly. However, using Bernoulli's equation, dynamic pressure can be calculated by measuring the total and static pressure acting on the aircraft. The system that accomplishes this measurement is the **pitot static system**. The pitot static system consists of a pitot tube that senses total pressure (H), a static port that senses static pressure (P_s), and a differential pressure gauge.

$$q = H - P_s$$

Pitot tubes are used to measure total pressure. A pitot tube is a hollow tube open at one end and closed at the back. The open end is exposed into the airflow and begins to fill with air (Figure 1-1-13). Soon, the pitot tube is completely filled with air and since there is nowhere for the air to go, all motion ceases. The motion ceases at the inlet to the tube as well. According to Bernoulli's equation, if velocity is zero, static pressure is equivalent to total pressure. The total pressure is measured at the closed end of the pitot tube.

Now that we have total pressure, we need to measure static pressure. A **Static port** measures static pressure. The static pressure port is a hole or series of small holes on the surface of the airplane's fuselage that are flush with the surface, and parallel to the airflow (Figure 1-11). Since the static port is parallel to the airflow, only ambient static pressure (P_s) affects the static port; no dynamic pressure is sensed.

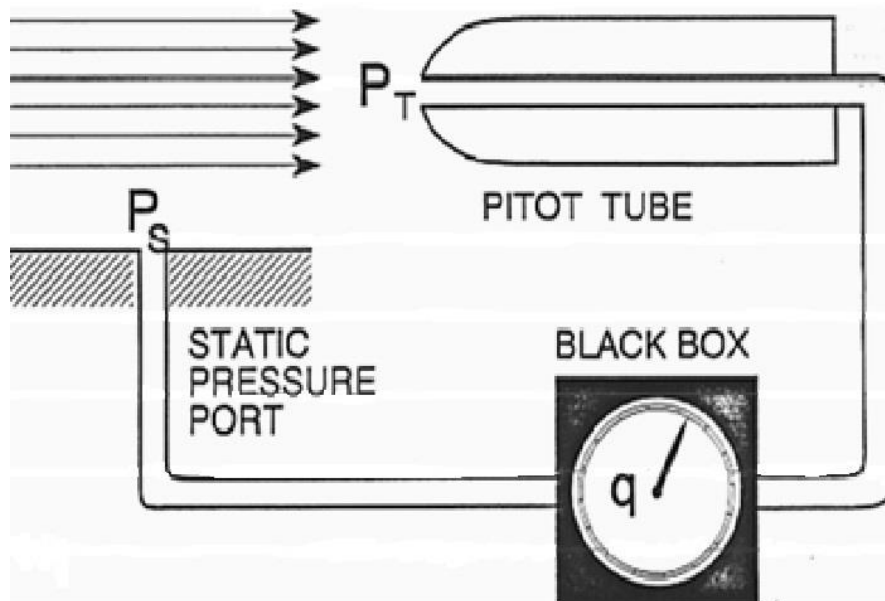

Figure 1-11 Pitot Static System

Now that we have both total pressure (H) from the pitot tube, and static pressure (P_s) from the static port, the differential pressure gauge measures the difference and has an output of dynamic pressure (q). Recalling Bernoulli's equation, and substituting for q :

$$H = P_s + \frac{1}{2} \rho V^2$$

By rearranging Bernoulli's equation, we are able to solve velocity for total and static pressure:

$$V = \sqrt{\frac{2(H - P_s)}{\rho}}$$

Where:

V = velocity

H = total pressure

P_s = static pressure

ρ = density

Using the equation above, we can now turn the difference measured by the pitot static system into useable velocity. The velocity is read on the airspeed indicator in the cockpit.

Indicated airspeed (IAS) is the actual instrument indication of the dynamic pressure the airplane is exposed to during flight. Factors such as altitude other than standard sea level, errors of the instrument and errors due to the installation, etc., may create great variances between instrument indication and the actual flight speed. The airspeed indicator is calibrated in knots of indicated airspeed (KIAS).

Instrument error is caused by the indicator errors and errors due to the physical location of the static port on the aircraft. Indicator error is small by design and is often negligible in properly maintained equipment. When the aircraft is operated through a large range of angles of attack, the static pressure distribution varies greatly and it becomes quite difficult to minimize the position error. In most instances a compensating group of static sources may be combined to reduce the position error. When indicated airspeed is corrected for instrument error, it is called **calibrated airspeed (CAS)**.

Compressibility error is caused by the ram effect of air in the pitot tube resulting in higher than normal airspeed indications at airspeeds approaching the speed of sound. The aerodynamics and mathematics for compressible flow are complex and outside the scope of this chapter; however, the compressibility corrections can usually be found in charts. **Equivalent airspeed (EAS)** is the true airspeed at sea level on a standard day that produces the same dynamic pressure as the actual flight condition. It is found by correcting calibrated airspeed for compressibility error.

True airspeed (TAS) is the actual velocity at which an airplane moves through an air mass. It is found by correcting equivalent airspeed for the difference between the local air density (ρ) and the density of the air at sea level on a standard day (ρ_0):

$$\rho(TAS)^2 = \rho_0(EAS)^2$$

$$TAS = EAS \sqrt{\frac{\rho_0}{\rho}}$$

As instrument error is typically small, and compressibility error is minor at subsonic velocities, we will ignore them and derive TAS directly from IAS:

$$TAS = IAS \sqrt{\frac{\rho_0}{\rho}}$$

The pitot static system is calibrated for standard sea level density, so TAS will equal IAS only under standard day conditions at sea level. Since air density decreases with an increase in temperature or altitude, if IAS remains constant while climbing from sea level to some higher altitude, TAS must increase. A rule of thumb is that for a constant IAS, TAS will increase approximately three knots for every thousand feet increase in altitude.

Ground speed is the airplane's actual speed over the ground. Since TAS is the actual speed of the airplane through the air mass, if we correct TAS for the movement of the air mass (wind), we will have ground speed. It is calculated using the following formulas:

$$GS = TAS - HEADWIND$$

$$GS = TAS + TAILWIND$$

“ICE-TG” is a helpful mnemonic device for the order of the airspeeds.

Major components of an airplane

An **aircraft** is any device used or intended to be used for flight in the air. It is normally supported either by the buoyancy of the structure (e.g. a balloon or dirigible) or by the dynamic reaction of the air against its surfaces (e.g. an airplane, glider or helicopter).

An **airplane** is a mechanically driven fixed-wing aircraft, heavier than air, which is supported by the dynamic reaction of the air against its wings. The T-6B is single-turboprop-engine, two-place, pressurized, low-wing training aircraft. It will be the primary example of a conventional airplane used throughout this course. The components of a conventional airplane are the fuselage, wings, empennage, landing gear, and engine(s) (Figure 1-12).

The **fuselage** is the basic structure of the airplane to which all other components are attached. It is designed to hold crewmembers, passengers, cargo, etc. Three basic fuselage types are possible: Truss, full monocoque, and semi-monocoque. The **truss** type consists of a metal or wooden frame over which a light skin is stretched. The truss supports the entire stress load of the airplane. It is very strong and easily repaired, but quite heavy. **Full**

monocoque is extremely light and strong because it consists of only a skin shell which is highly stressed, but is almost impossible to repair if damaged. The skin supports the entire stress load of the aircraft. **Semi-monocoque** is a modified version of monocoque, having skin, transverse frame members, and stringers, which all share in stress loads and may be readily repaired if damaged. The T-6B uses a semi-monocoque fuselage.

The **wing** is an airfoil attached to the fuselage and is designed to produce lift. It may contain control surfaces, fuel cells, engine nacelles, and landing gear. **Ailerons** are one of three major control surfaces of an airplane and are attached to the wing to control roll. Flaps and slots are high lift devices attached to the wing to increase lift at low airspeeds. The T-6B has a single low-mounted wing with split flaps integrated into the trailing edge inboard of the ailerons. Since all bracing is internal, the wings are considered to be **full cantilever**.

The **empennage** is the assembly of stabilizing and control surfaces on the tail of an airplane. It provides the greatest stabilizing influence of all the components of the conventional airplane. The empennage consists of the aft part of the fuselage, the vertical stabilizer, and the horizontal stabilizer. The **rudder** is one of three major control surfaces of an airplane and is the upright control surface attached to the vertical stabilizer to control yaw. **Elevators** are one of the three major control surfaces of an airplane and are the horizontal control surfaces attached to the horizontal stabilizer to control pitch.

The **landing gear** permits ground taxi operation and absorbs the shock encountered during takeoff and landing. The T-6B has retractable tricycle landing gear that includes a steerable nosewheel and two main wheels. During taxi operations steering is controlled by either nosewheel steering, which is accomplished using rudder pedals, rudder, and/or differential braking.

The **engine** provides the thrust necessary for powered flight. Military and commercial airplanes may be fitted with multiple turboprop, turbojet, or turbofan engines. The type of engine depends on the mission requirements of the aircraft. The T-6B has a PT6A-68 turboprop engine.

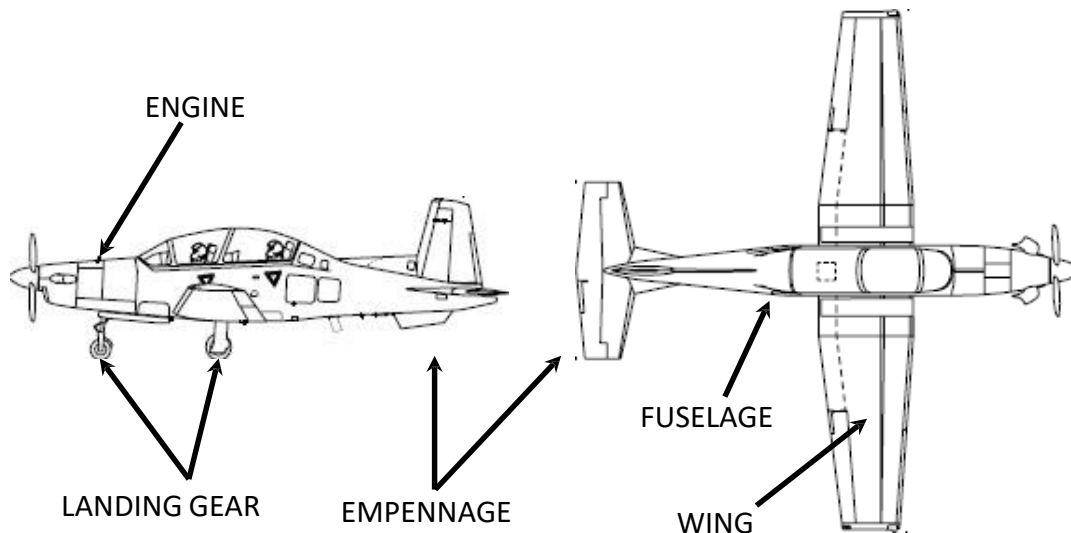

Figure 1-12 Airplane Components

AIRFOILS AND WING PROPERTIES

Aircraft wings are designed to take advantage of atmospheric and airflow properties. The cross-sectional shape obtained by the intersection of the wing with a perpendicular plane is called an airfoil (Figure 1-13). An airfoil is a streamlined shape designed to produce lift as it moves through the air.

The major design characteristic of an airfoil is the mean camber line. The **mean camber line (MCL)** is a line halfway between the upper and lower surface of an airfoil. The most forward and rearward points of the mean camber line are the leading edges and trailing edges, respectively. The **chord line** of an airfoil is an infinitely long, straight line which passes through its leading and trailing edges. **Chord** is the precise measurement between the leading and trailing edges measured along the chord line. Chord will typically vary from the wingtip to the wing root. The **root chord (c_R)** is the chord at the wing centerline and the **tip chord (c_T)** is measured at the wingtip. The **average chord (c)** is the average of every chord from the wing root to the wingtip. The **camber** of an airfoil is the maximum distance between the mean camber line and the chord line, measured perpendicular to the chord line.

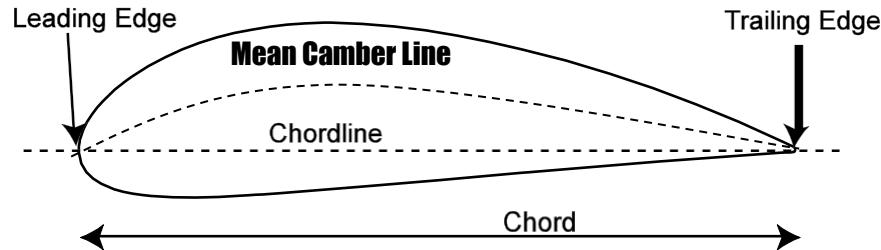

Figure 1-13 Wing Cross-Section View

There are three types of airfoils: positively cambered, symmetric and negatively cambered. Positively cambered airfoils have the MCL above the chord line. A positively cambered airfoil produces lift at zero angle of attack. A symmetric airfoil has zero camber, which indicates that the MCL and the chord line are the same. A symmetric airfoil produces no lift at zero angle of attack. A negatively cambered airfoil has the MCL below the chord line and will produce negative lift at zero angle of attack.

The **aerodynamic center** is the point along the chord line around which all changes in the aerodynamic force take place. On a subsonic airfoil, the aerodynamic center is located approximately one-quarter (between 23% and 27%) of the length of the chord from the leading edge. The aerodynamic center will remain essentially stationary unless the airflow over the wings approaches the speed of sound. Transonic and supersonic flight are not discussed in course.

Wingspan (b) is the length of a wing, measured from wingtip to wingtip. It always refers to the entire wing, not just the wing on one side of the fuselage. The wingspan of the T-6B is 33'5".

Wing area (S) is the apparent surface area of a wing from wingtip to wingtip (Figure 1-14). More precisely, it is the area within the outline of a wing in the plane of its chord, including that area within the fuselage, hull or nacelles. The formula for S is:

$$S = bc$$

Taper is the reduction in the chord of an airfoil from root to tip (Figure 1-14). The wings of the T-6B are tapered to reduce weight, improve structural stiffness, and reduce wingtip vortices. Assuming the wing to have straight leading and trailing edges, taper ratio (λ) is the ratio of the tip chord to the root chord.

$$\lambda = \frac{c_T}{c_R}$$

Sweep angle (Λ) is the angle between the lateral axis and a line drawn 25% aft of the leading edge (Figure 1-14). Sweep angle is not parallel to the leading edge on a tapered wing. Wing sweep affects maximum lift and stall characteristics. The T-6B wing is swept.

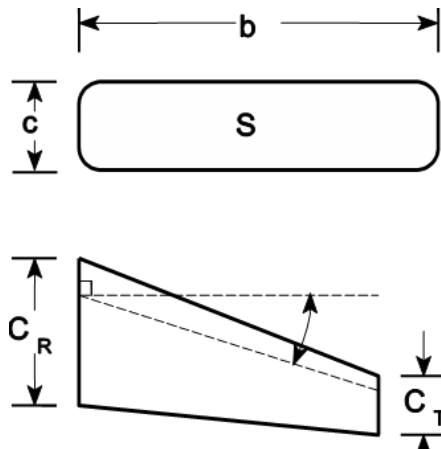

Figure 1-14 Wing Planform Views

Aspect ratio (AR) is the ratio of the wingspan to the average chord. An aircraft with a high aspect ratio (35:1), such as a glider, would have a long, slender wing. A low aspect ratio (3:1) indicates a short, stubby wing, such as on a high performance jet.

$$AR = \frac{b}{c}$$

Wing loading (WL) is the ratio of an airplane's weight to the surface area of its wings. There tends to be an inverse relationship between aspect ratio and wing loading. Gliders have high aspect ratios and low wing loading. Fighters with low aspect ratios maneuver at high g-loads and are designed with high wing loading. The wing loading formula is:

$$WL = \frac{W}{S}$$

The **angle of incidence** of a wing is the angle between the airplane's longitudinal axis and the chord line of the wing (Figure 1-15).



Figure 1-15 Angle of Incidence

Dihedral angle is the angle between the spanwise inclination of the wing and the lateral axis (Figure 1-16). More simply, it is the upward slope of the wing when viewed from the front. A negative dihedral angle is called an **anhedral** angle (sometimes cathedral). The T-6B has dihedral wings to improve lateral stability.

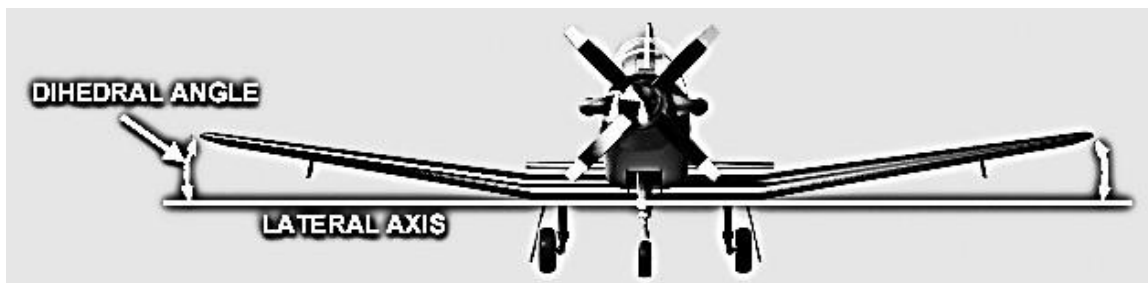

Figure 1-16 Dihedral Angle

AIRPLANE REFERENCE SYSTEM

An airplane's reference system consists of three mutually perpendicular axes referenced to the center of gravity (Figure 1-17). As an airplane moves through the air, the axis system also moves. Therefore, the movement of the airplane can be described by the movement of its center of gravity. The **center of gravity (CG)** is the point at which all weight is considered to be concentrated and about which all forces and moments are measured. Theoretically, the airplane will balance if suspended at the center of gravity. As fuel burns, ordnance is expended or cargo loaded/unloaded, the CG can shift.

The **longitudinal axis** passes from the nose to the tail of the airplane. Movement around the longitudinal axis is called **roll**. The **lateral axis** passes from wingtip to wingtip. Movement around the lateral axis is called **pitch**. The **vertical axis** passes vertically through the center of gravity. Movement of the longitudinal axis around the vertical axis is called **yaw**.

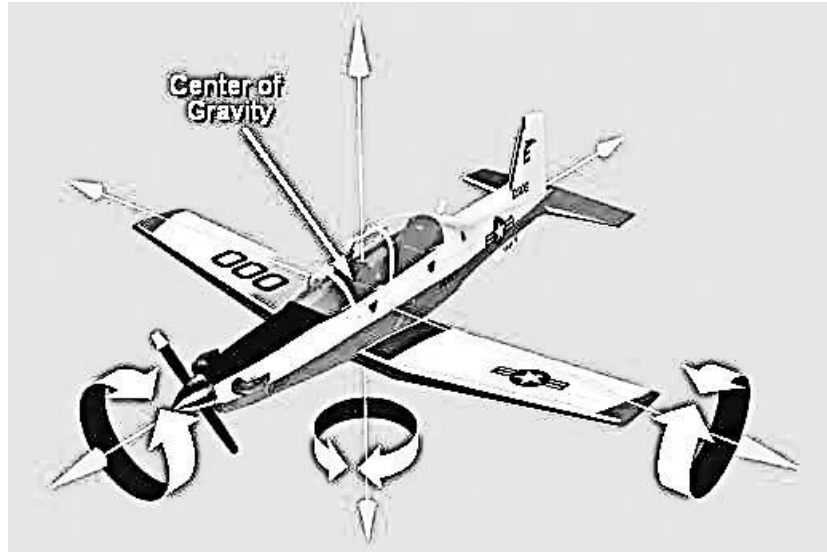

Figure 1-17 Airplane Reference System

Pitch attitude (θ) is the angle between an airplane's longitudinal axis and the horizon. An airplane's **flight path** is the path described by its center of gravity as it moves through an air mass. **Relative wind** is the airflow the airplane experiences as it moves through the air. It is equal in magnitude and opposite in direction to the flight path.

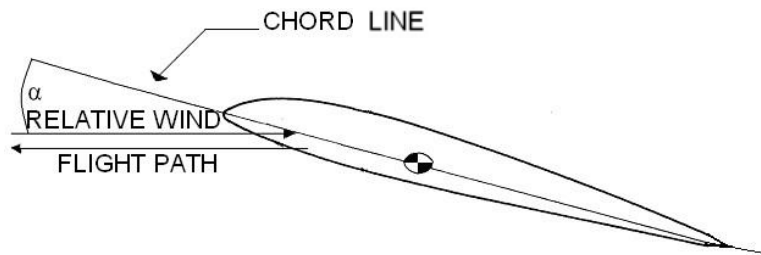

Figure 1-18 Flight Path, Relative Wind and Angle of Attack

Angle of attack (α) is the angle between the relative wind and the chord line of an airfoil. Angle of attack is often abbreviated AOA.

Flight path, relative wind, and angle of attack should never be inferred from pitch attitude.

Spanwise flow is airflow that travels along the span of the wing, parallel to the leading edge. Spanwise flow is normally from the root to the tip. This airflow is not accelerated over the wing and therefore produces no lift.



Chordwise flow is air flowing at right angles to the leading edge of an airfoil. Since chordwise flow is the only flow that accelerates over a wing, it is the only airflow that produces lift.



ASSIGNMENT SHEET 2-1-3

BASIC THEORY REVIEW

A. INTRODUCTION

This lesson is a basic introduction to the theory of aerodynamics. It provides a knowledge base in aerodynamic mathematics, air properties, airspeed and altitude definitions and measurements, airfoil and wing design, and the importance of center of gravity (CG).

B. ENABLING OBJECTIVES

C. STUDY ASSIGNMENT

1. Review Naval Aviation Fundamentals, NAVAVSCOLSCOM-SG-200 Unit 2, Chapter 1
2. Read Naval Aviation Fundamentals, NAVAVSCOLSCOM-SG-200 Unit 2, Chapter 2

D. STUDY QUESTIONS

1. A moment is _____.
 - a. the force with which a mass is attracted toward the center of the earth
 - b. the result of mass x acceleration
 - c. a body's capacity to do work
 - d. created when a force is applied at some distance from an axis or fulcrum, producing rotation about that point
2. Mass per unit of volume defines which of the following?
 - a. Work
 - b. Play
 - c. Density
 - d. Power
3. Potential energy is _____.
 - a. the ability of a body to do work due to its motion
 - b. dependent on mass and velocity
 - c. a scalar measure of a body's capacity to do work
 - d. the ability of a body to do work due to its position or state of being

4. The Law of Interaction states _____.
 - a. “For every action there is an equal and opposite reaction.”
 - b. “A body at rest tends to stay at rest.”
 - c. “Two opposite forces cannot interact.”
 - d. “An unbalanced force acting upon a body produces an acceleration in the direction of the force that is directly proportional to the force and inversely proportional to the mass of the body.”

5. True airspeed will be _____ indicated airspeed at 10,000 feet MSL.
 - a. less than
 - b. equal to
 - c. greater than
 - d. not enough information to determine

6. The chord of an airfoil is defined as _____.
 - a. the angle between the longitudinal axis and the horizon
 - b. a measure of the wing along the chord line, from the leading edge to the trailing edge
 - c. an infinitely long line drawn through the leading and trailing edges of an airfoil
 - d. the length of a wing

7. Air density is _____ at 10,000 feet compared to _____ feet.
 - a. lower/5000
 - b. equal/5000
 - c. equal/20,000
 - d. lower/20,000

8. The altimeter setting for standard day where pressure altitude equals true altitude is _____ in-Hg.
 - a. 29.92
 - b. 92.29
 - c. 92.92
 - d. 1013.2

9. The center of gravity is the point at which _____.
 - a. lift is generated
 - b. all aerodynamic forces are concentrated
 - c. elevator authority is lost
 - d. all weight is concentrated

10. The _____ axis is which the aircraft nose moves left or right about the center of gravity.
 - a. center
 - b. yaw
 - c. pitch
 - d. roll

Answers:

- | | |
|-----|-------|
| 1.D | 6. B |
| 2.C | 7. A |
| 3.D | 8. A |
| 4.A | 9. D |
| 5.C | 10. B |

OUTLINE SHEET 2-2-1

LIFT PRODUCTION AND DRAG

A. INTRODUCTION

This lesson is a continuation of aerodynamic principles from Lesson 2.1. Definitions of lift, weight, thrust and drag and how each relates to one another on an aircraft will be presented. Basic configuration principles and effects on lift production will also be discussed.

B. ENABLING OBJECTIVES

- 2.80 EXPLAIN the aerodynamic relationship of the four primary forces of equilibrium flight, in a classroom, in accordance with Naval Aviation Fundamentals, NAVAVSCOLSCOM-SG-200
- 2.81 DESCRIBE how the primary aerodynamic forces affect each other, in a classroom, in accordance with Naval Aviation Fundamentals, NAVAVSCOLSCOM-SG-200
- 2.82 STATE the pressure distribution around an airfoil, given changes in angle of attack and camber, in a classroom, in accordance with Naval Aviation Fundamentals, NAVAVSCOLSCOM-SG-200
- 2.83 DEFINE the lift component of aerodynamic force, in a classroom, in accordance with Naval Aviation Fundamentals, NAVAVSCOLSCOM-SG-200
- 2.84 DESCRIBE how factors in the lift equation affect lift production, given density, velocity, surface area, and coefficient of lift, in a classroom, in accordance with Naval Aviation Fundamentals, NAVAVSCOLSCOM-SG-200
- 2.85 LIST the factors affecting coefficient of lift that the pilot can directly control, in a classroom, in accordance with Naval Aviation Fundamentals, NAVAVSCOLSCOM-SG-200
- 2.86 DEFINE the drag component of aerodynamic force, in a classroom, in accordance with Naval Aviation Fundamentals, NAVAVSCOLSCOM-SG-200
- 2.87 DEFINE parasite drag and its components: form, friction, and interference drag, in a classroom, in accordance with Naval Aviation Fundamentals, NAVAVSCOLSCOM-SG-200

- 2.88 DESCRIBE the measures that can be taken to reduce each of the components of parasite drag, in a classroom, in accordance with Naval Aviation Fundamentals, NAVAVSCOLSCOM-SG-200
- 2.89 STATE the effects of upwash and downwash on an infinite wing, in a classroom, in accordance with Naval Aviation Fundamentals, NAVAVSCOLSCOM-SG-200
- 2.90 STATE the effects of upwash and downwash on a finite wing, in a classroom, in accordance with Naval Aviation Fundamentals, NAVAVSCOLSCOM-SG-200
- 2.91 DEFINE induced drag, in a classroom, in accordance with Naval Aviation Fundamentals, NAVAVSCOLSCOM-SG-200
- 2.92 STATE the cause of induced drag on a finite wing, in a classroom, in accordance with Naval Aviation Fundamentals, NAVAVSCOLSCOM-SG-200
- 2.93 DESCRIBE factors affecting induced drag, given the induced drag equation, and changes in lift, weight, density velocity, and wingspan, in a classroom, in accordance with Naval Aviation Fundamentals, NAVAVSCOLSCOM-SG-200
- 2.94 STATE when a plane will enter ground effect, in a classroom, in accordance with Naval Aviation Fundamentals, NAVAVSCOLSCOM-SG-200
- 2.95 STATE the effects of ground effect on lift, effective lift, and induced drag, in a classroom, in accordance with Naval Aviation Fundamentals, NAVAVSCOLSCOM-SG-200
- 2.96 DESCRIBE effects of angle of attack changes on coefficient of lift and coefficient of drag, in a classroom, in accordance with Naval Aviation Fundamentals, NAVAVSCOLSCOM-SG-200
- 2.97 EXPLAIN the lift to drag ratio, using the lift and drag equations, in a classroom, in accordance with Naval Aviation Fundamentals, NAVAVSCOLSCOM-SG-200
- 2.98 EXPLAIN the importance of L/D MAX, in a classroom, in accordance with Naval Aviation Fundamentals, NAVAVSCOLSCOM-SG-200
- 2.99 DEFINE total drag, in a classroom, in accordance with Naval Aviation Fundamentals, NAVAVSCOLSCOM-SG-200
- 2.100 DESCRIBE the effects of changes in velocity on total drag, in a classroom, in accordance with Naval Aviation Fundamentals, NAVAVSCOLSCOM-SG-200
- 2.101 DEFINE thrust components: thrust required and thrust available, in a classroom, in accordance with Naval Aviation Fundamentals, NAVAVSCOLSCOM-SG-200

- 2.102 DEFINE power components: power required and power available, in a classroom, in accordance with Naval Aviation Fundamentals, NAVAVSCOLSCOM-SG-200
- 2.103 DESCRIBE the effects of throttle setting, velocity, and density, on thrust available and power available, in a classroom, in accordance with Naval Aviation Fundamentals, NAVAVSCOLSCOM-SG-200
- 2.104 DEFINE thrust horsepower and components: shaft horsepower and propeller efficiency, in a classroom, in accordance with Naval Aviation Fundamentals, NAVAVSCOLSCOM-SG-200
- 2.105 STATE the maximum rated shaft horsepower in the T-6B, in a classroom, in accordance with Naval Aviation Fundamentals, NAVAVSCOLSCOM-SG-200
- 2.106 EXPLAIN how propeller efficiency affects thrust horsepower, in a classroom, in accordance with Naval Aviation Fundamentals, NAVAVSCOLSCOM-SG-200
- 2.107 DESCRIBE power required in terms of thrust required, in a classroom, in accordance with Naval Aviation Fundamentals, NAVAVSCOLSCOM-SG-200
- 2.108 STATE the location of L/D MAX on the thrust required and power required curves, in a classroom, in accordance with Naval Aviation Fundamentals, NAVAVSCOLSCOM-SG-200
- 2.109 DESCRIBE how thrust required and power required vary with velocity, in a classroom, in accordance with Naval Aviation Fundamentals, NAVAVSCOLSCOM-SG-200
- 2.110 DEFINE excess thrust and excess power, in a classroom, in accordance with Naval Aviation Fundamentals, NAVAVSCOLSCOM-SG-200
- 2.111 DESCRIBE the effects of excess thrust and excess power, in a classroom, in accordance with Naval Aviation Fundamentals, NAVAVSCOLSCOM-SG-200
- 2.112 DESCRIBE the effects of changes in weight on thrust and power components: thrust required, power required, excess thrust, and excess power, in a classroom, in accordance with Naval Aviation Fundamentals, NAVAVSCOLSCOM-SG-200
- 2.113 DESCRIBE the effects of changes in altitude on thrust and power components: thrust required, power required, thrust available, power available, excess thrust, and excess power, in a classroom, in accordance with Naval Aviation Fundamentals, NAVAVSCOLSCOM-SG-200

- 2.114 DESCRIBE the effects of changes in configuration on thrust and power components: thrust required, power required, excess thrust, and excess power, in a classroom, in accordance with Naval Aviation Fundamentals, NAVAVSCOLSCOM-SG-200
- 2.115 DESCRIBE the aerodynamic effects of raising or lowering the flaps, in a classroom, in accordance with Naval Aviation Fundamentals, NAVAVSCOLSCOM-SG-200
- 2.116 DESCRIBE the aerodynamic effects of raising and lowering the landing gear, in a classroom, in accordance with Naval Aviation Fundamentals, NAVAVSCOLSCOM-SG-200
- 2.117 EXPLAIN the aerodynamic effects of each primary flight control on the aircraft, in a classroom, in accordance with Naval Aviation Fundamentals, NAVAVSCOLSCOM-SG-200
- 2.118 DESCRIBE how the trim tab system holds an airplane in trimmed flight, in a classroom, in accordance with Naval Aviation Fundamentals, NAVAVSCOLSCOM-SG-200
- 2.119 DEFINE aerodynamic balancing and mass balancing, in a classroom, in accordance with Naval Aviation Fundamentals, NAVAVSCOLSCOM-SG-200
- 2.120 STATE the methods for aerodynamic and mass balancing employed on the T-6B, in a classroom, in accordance with Naval Aviation Fundamentals, NAVAVSCOLSCOM-SG-200
- 2.121 STATE the characteristics of the three basic types of control systems, in a classroom, in accordance with Naval Aviation Fundamentals, NAVAVSCOLSCOM-SG-200
- 2.122 STATE how trim tabs can be used to generate artificial feel on a control surface, in a classroom, in accordance with Naval Aviation Fundamentals, NAVAVSCOLSCOM-SG-200
- 2.123 DESCRIBE the purpose of bobweights and downsprings, in a classroom, in accordance with Naval Aviation Fundamentals, NAVAVSCOLSCOM-SG-200

C. TOPIC OUTLINE

1. Introduction
2. This Lesson Topic
3. Equilibrium
4. Aerodynamic Force
5. Pressure Distribution
6. Factors Affecting Lift
7. Parasite Drag
8. Induced Drag
9. Lift to Drag Ratio
10. Thrust and Power Available
11. Thrust and Power Required
12. Horsepower and Propeller Efficiency
13. Excess Thrust and Power
14. Factors Affecting Excess Thrust and Power
15. Flight Controls
16. Trim
17. Aerodynamic Balancing and Mass Balancing
18. Control Systems
19. Artificial Feel
20. Summary and Review
21. Application
22. Assignment

INFORMATION SHEET 2-2-2

LIFT PRODUCTION AND DRAG

A. INTRODUCTION

This lesson is a continuation of aerodynamic principles from Lesson 2.1. Definitions of lift, weight, thrust and drag and how each relates to one another on an aircraft will be presented. Basic configuration principles and effects on lift production will also be discussed.

B. REFERENCES

1. Aerodynamics for Naval Aviators, NAVAIR 00-80T-80
2. Introduction to the Aerodynamics of Flight, NASA SP-367
3. T-6 Joint Primary Pilot Training, AETC / CNATRA Syllabus P-V4A-J NATOPS Flight Manual

C. INFORMATION

PRIMARY FORCES

There are four primary forces that act on an aircraft: Lift, Weight, Thrust, and Drag. Weight is the force of the Earth's gravity acting on the mass of the aircraft. It is always pointed towards the center of the Earth. Thrust is the force produced by a jet engine or engine/propeller combination. Lift is the force that primarily acts against weight. Drag is the force that primarily acts against thrust and retards aircraft motion. Lift and drag are components of the aerodynamic force which will be discussed in greater detail next.

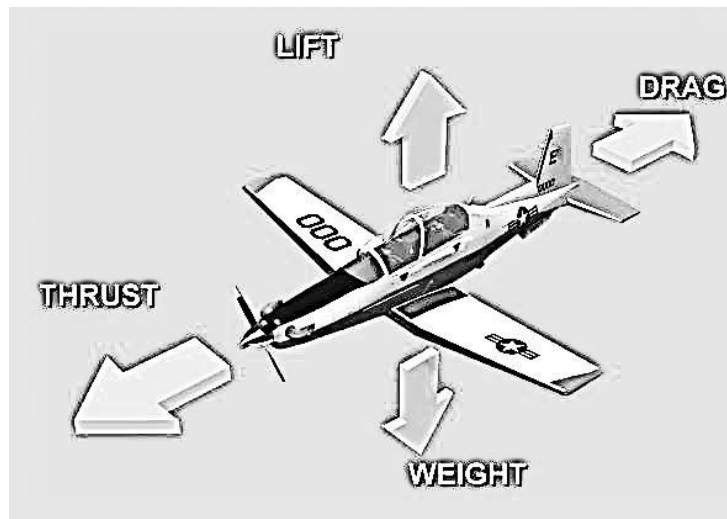

AERODYNAMIC FORCE

Figure 2-1 Aerodynamic Forces

The only mechanisms nature has for communicating a force to a body moving through a fluid are pressure and shear stress distributions on the body surface. Pressure acts normal (perpendicular) to the body while shear stress acts tangential to the surface. When integrated over the entire surface, the resultant vector is the aerodynamic force. The aerodynamic force (AF) is the net force that results from pressure and shear stress distribution over an airfoil, and can be broken down into two components, lift and drag (Figure 2-1). Lift (L) is the component of the aerodynamic force acting perpendicular to the relative wind. Drag (D) is the component of the aerodynamic force acting parallel to and in the same direction as the relative wind.

Aerodynamic force can be expressed as the product of dynamic pressure (q), surface area (S) of the airfoil, and a coefficient of aerodynamic force (C_F). This coefficient represents the shape and orientation of the surface area with respect to the relative wind. The equation is:

$$AF = qSC_F = \frac{1}{2} \rho V^2 SC_F$$

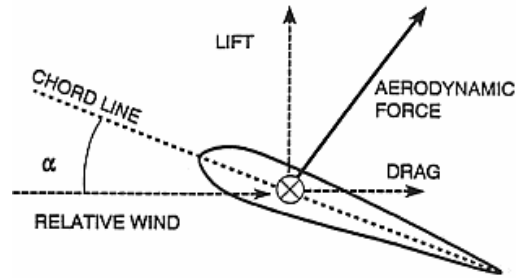
Because lift and drag are components of aerodynamic force, they are also functions of dynamic pressure, surface area and a coefficient that represents the shape and orientation of the surface area. They are expressed as:

$$L = qSC_L = \frac{1}{2} \rho V^2 SC_L$$

$$D = qSC_D = \frac{1}{2} \rho V^2 SC_D$$

Where:

C_L = Coefficient of Lift

C_D = Coefficient of Drag

LIFT**PRODUCTION OF LIFT**

As stated above, pressure and shear stress are the only two aerodynamic forces that can act on a body. Because lift is the component of the resultant force in the perpendicular direction and because the pressure on the surface, at reasonable angles of attack, acts mainly in the lift direction

we can say that lift is mainly due to an imbalance of pressure distributions over the top and bottom surface.

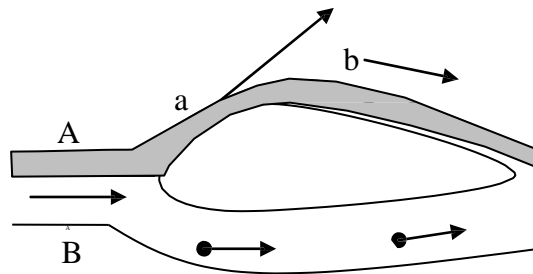

Figure 2-2 Airflow Around a Positive Cambered Airfoil

Figure 2-2 shows two streamtubes flowing around a positively cambered airfoil. The shaded streamtube A flows over the airfoil and streamtube B flows underneath the airfoil. Both streamtubes originate in the free stream ahead of the airfoil. As the streamtube A flows toward the airfoil, it senses the upper portion of the airfoil as an obstruction and must flow around it. In doing so, streamtube A is reduced to a smaller cross-sectional area as it flows over the leading edge of the airfoil. Because of the mass continuity equation ($\rho AV = \text{constant}$), the velocity in the streamtube must increase. The higher velocity at point a is shown by the long arrow. As the flow continues past point a, the cross-sectional area increases and flow velocity decreases, as shown by the smaller velocity arrow at point b. Because the airfoil is positively cambered, streamtube B sees less of an obstruction when flowing over the bottom of the airfoil. Therefore, streamtube B does not have the same reduction in cross-sectional area as streamtube A, resulting in a lower velocity.

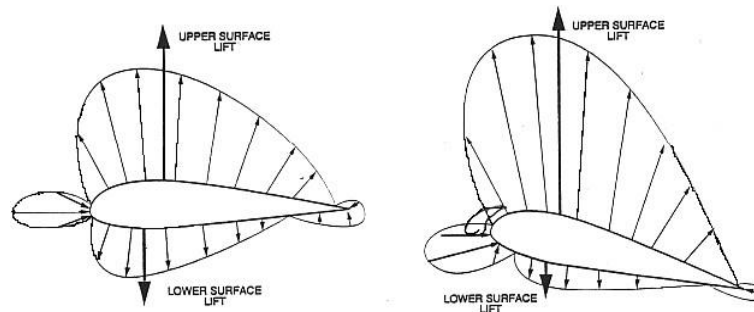

Figure 2-3 Pressure Distribution Around Positively Cambered Airfoil at Zero and Positive AOA

Bernoulli's equation stated that for incompressible flow, $P_s + \frac{1}{2} \rho V^2$ is constant. Therefore, as velocity increases, static pressure decreases. This is called the Bernoulli effect. Finally, because the lower static pressure over the top surface of the airfoil is less than the static pressure on the lower surface, the airfoil experiences a lift force in the upward direction (Figure 2-3).

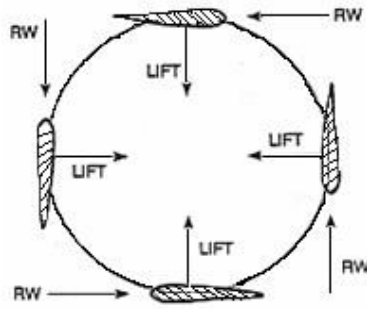

Figure 2-4 Lift in a Loop

Although lift is often thought of as an upward force opposing weight, it can act in any direction. It is always perpendicular to the relative wind, not the horizon. In Figure 2-4, the relative wind and lift vectors are shown for an airfoil during a loop maneuver. Note that the lift vector is always perpendicular to the relative wind.

Increasing the angle of attack results a continued reduction of the cross-sectional area of the streamtube flowing over the top surface of an airfoil, resulting in more lift being created (Figure 2-5). Angle of attack will be discussed in greater detail later.

It is sometimes written that a fluid element that comes to the leading edge splits into two elements, one of which flows over the top surface and the other over the bottom surface. It is then assumed that the two elements meet at the trailing edge and since the distance over the top of the surface is longer than over the bottom that the top element needed to move faster. This is a common misconception and not true. Experimental results and complex mathematics show that the element traveling over the top surface of the airfoil departs the surface long before the companion element reaches the trailing edge.

A symmetric airfoil at zero angle of attack produces identical velocity increases and static pressure decreases on both the upper and lower surfaces. Since there is no pressure differential perpendicular to the relative wind, the airfoil produces zero net lift.

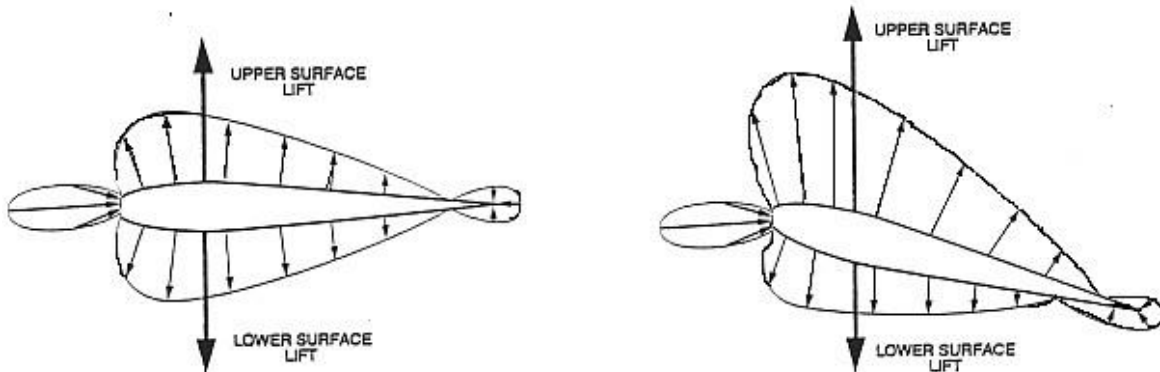

Figure 2-5 Pressure Distribution Around Symmetric Airfoil at Zero and Positive AOA

FACTORS AFFECTING LIFT

$$L = qSC_L = \frac{1}{2} \rho V^2 SC_L$$

There are eight factors that affect lift: density (ρ), velocity (V), surface area (S), compressibility, aspect ratio (AR), viscosity (μ), angle of attack (α), and camber. Compressibility, aspect ratio, viscosity, angle of attack, and camber are accounted for in the coefficient of lift.

When an airfoil is exposed to greater dynamic pressure (q), it encounters more air particles and thus produces more lift. Therefore, lift is dependent upon the density of the air (i.e., the altitude) and the velocity of the airflow. An increase in density or velocity will increase lift.

Since lift is produced by pressure, which is force per unit area, it follows that a greater area produces a greater force. Therefore, an increase in wing surface area produces greater lift.

The pilot has no control over viscosity and compressibility. Viscosity and compressibility will vary with altitude, airspeed, air composition and many other factors. Because there is no way to control viscosity, or compressibility, they will be ignored in this discussion unless specifically addressed. Aspect ratio deals with the shape of the wing. In swing-wing aircraft wing sweep can be controlled. However, since these aircraft are no longer common, aspect ratio will also be ignored in this discussion unless specifically addressed.

The two aspects of the coefficient of lift that can be controlled are the shape of the airfoil and the AOA.

AOA is the most important factor in the coefficient of lift, and the easiest for the pilot to change. As angle of attack increases, the coefficient of lift initially increases. In order to maintain level flight while increasing angle of attack, velocity must decrease. Otherwise, lift will be greater than weight and the airplane will climb. Velocity and angle of attack are inversely related in level flight.

$$L = \frac{1}{2} \rho \overset{\downarrow}{V^2} \overset{\uparrow}{S} C_L$$

As angle of attack increases, the coefficient of lift increases up to a maximum value ($C_{L_{\max}}$). The AOA at which $C_{L_{\max}}$ is reached is called $C_{L_{\max}}$ AOA (Figure 4-6). Any increase in angle of attack beyond $C_{L_{\max}}$ AOA causes a decrease in the coefficient of lift. Since $C_{L_{\max}}$ is the greatest coefficient of lift that can be produced, we call $C_{L_{\max}}$ AOA the most effective angle of attack. Note that as long as the shape of an airfoil remains constant, $C_{L_{\max}}$ AOA will remain constant, regardless of weight, dynamic pressure, bank angle, etc.

Figure 2-6 plots C_L as it varies with AOA. These curves are for three different airfoils: One symmetric, one negative camber and one positive camber. The shape of the C_L curve is similar for most airfoils. At zero angle of attack, the positive camber airfoil has a positive C_L , and the negative camber airfoil has a negative C_L . The point where the curves cross the horizontal axis is the AOA where the airfoil produces no lift ($C_L = 0$). At zero AOA the symmetric airfoil has $C_L = 0$. The positive camber airfoil must be at a negative AOA, and the negative camber airfoil must be at a positive AOA for the C_L to equal zero.

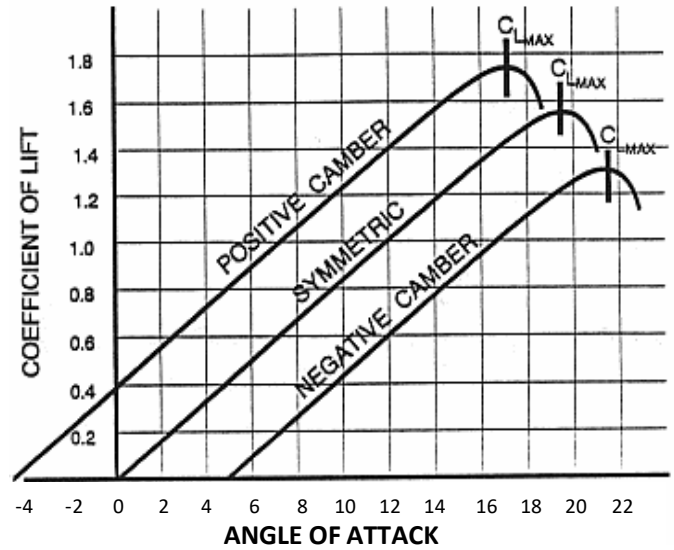

Figure 2-6 Camber vs. AOA

DRAG

Drag is the component of the aerodynamic force that is parallel to the relative wind, and acts in the same direction. The drag equation is the same as the aerodynamic force equation, except that the coefficient of drag (C_D) is used.

$$D = \frac{1}{2} \rho V^2 S C_D$$

C_D may be plotted against angle of attack for a given aircraft with a constant configuration (Figure 2-7). Note that C_D is low and nearly constant at very low angles of attack. As angle of attack increases, C_D rapidly increases. Since there is always some resistance to motion, drag will never be zero, so C_D will never be zero. Drag is divided into parasite drag and induced drag. By independently studying the factors that affect each type, we can better understand how they act when combined.

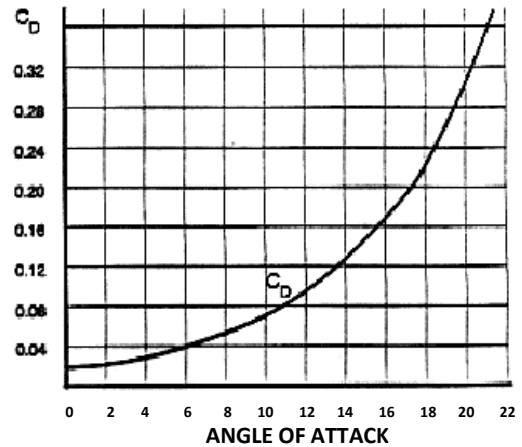

Figure 2-7 Coefficient of Drag

$$D_T = D_P + D_I$$

PARASITE DRAG

Parasite drag (D_P) is drag that is not associated with the production of lift. It is composed of form drag, friction drag and interference drag.

Form drag, also known as pressure drag or profile drag, is caused by airflow separation from a surface and the low pressure wake that is created by that separation. It is primarily dependent upon the shape of the object. In Figure 2-8, the flat plate has a leading edge stagnation point at the front with a very high static pressure. There is also a low static pressure wake area behind the plate. This pressure differential pulls the plate backward and retards forward motion. Conversely, streamlines flow smoothly over a smooth shape (Figure 2-9 and Figure 2-10) and less form drag is developed.

To reduce form drag, the fuselage and other surfaces exposed to the airstream are streamlined (shaped like a teardrop). Streamlining reduces the size of the high static pressure area near the leading edge stagnation point and reduces the size of the low static pressure wake. Because of the decreased pressure differential, form drag is decreased.

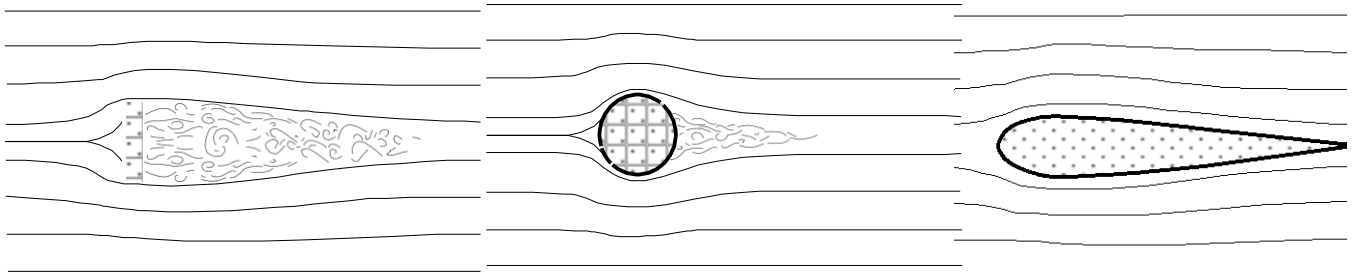

Figure 2-8 Flat Plate

Figure 2-9 Sphere

Figure 2-10 Streamlining

Due to viscosity, a retarding force called friction drag is created as air interacts with the surfaces of an object. Friction drag is usually small per unit area, but since it covers the entire surface of the airplane, friction drag can become significant in larger airplanes. Rough surfaces create irregularities that increase skin friction.

Friction drag can be reduced by smoothing the exposed surfaces of the airplane through painting, cleaning, waxing or polishing. Since irregularities of the wing's surface cause the boundary layer to become turbulent, using flush rivets on the leading edges also reduces friction.

Greater friction drag can be useful in decreasing form drag. Recall that form drag increased with the size of the low pressure wake that resulted from airflow separation around an object. Delaying the separation of airflow reduces the form drag encountered. Friction drag allows airflow to adhere to a surface longer, delaying airflow separation and reducing the size of the turbulent wake. The dimples on a golf ball (Figure 2-11) reduce the overall parasite drag on the ball by reducing the size of the turbulent wake. The reduction in form drag is greater than the increase in friction drag and allows the dimpled golf ball to travel further than a smooth golf ball.

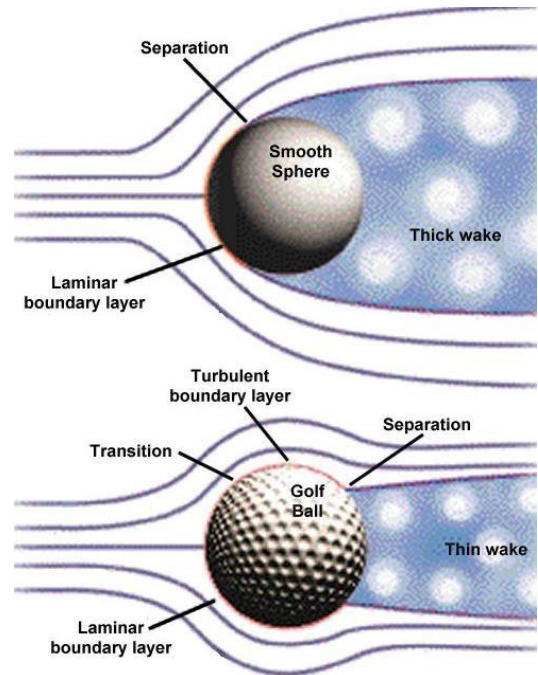
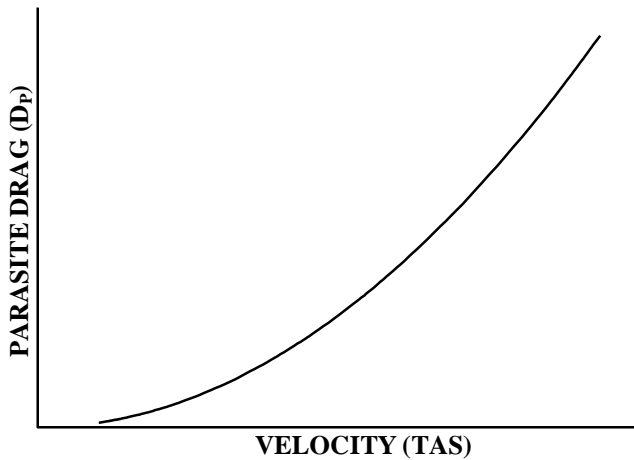

Figure 2-11 Dimples on a Golf Ball

Interference drag is generated by the mixing of streamlines between components. An example is the air flowing around the fuselage mixing with air flowing around an external fuel tank. We know the drag of the fuselage and the drag of the fuel tank individually. The total drag after we attach the fuel tank will be greater than the sum of the fuselage and the fuel tank separately. Roughly 5 to 10 percent of the total drag on an airplane can be attributed to interference drag. Interference drag can be minimized by proper fairing and filleting, which allows the streamlines to meet gradually rather than abruptly.

Figure 2-12 D_p vs. Velocity

Total parasite drag (D_p) can be found by multiplying dynamic pressure by an area. Equivalent parasite area (f) is the area of a flat plate perpendicular to the relative wind that would produce the same amount of drag as form drag, friction drag and interference drag combined. It is not the cross-sectional area of the airplane. The equation for DP is:

$$D_p = \frac{1}{2} \rho V^2 f = qf$$

Parasite drag varies directly with velocity squared (V^2), so a doubling of speed will result in four times as much parasite drag (Figure 2-12).

INDUCED DRAG

INFINITE WING

Consider a wing placed in a wind tunnel with the tips flush against the walls. For all practical purposes it has no wingtips and is called an infinite wing. The relative wind on an infinite wing can only flow chordwise, and therefore produces lift. As the relative wind flows around the infinite wing, the high pressure air under the leading edge attempts to equalize with the low pressure air above the wing. The shortest route is around the leading edge. This results in some of the air that otherwise would have passed under the wing flowing up and over the leading edge. This flow is called upwash. Upwash increases lift because it increases the average angle of attack on the wing. Some of the air on top of the wing also flows down and under the trailing edge. This flow is called downwash. Downwash decreases lift by reducing the average angle of attack on the wing. For an infinite wing, the upwash exactly balances the downwash resulting in no net change in lift. Upwash and downwash exist any time an airfoil produces lift.

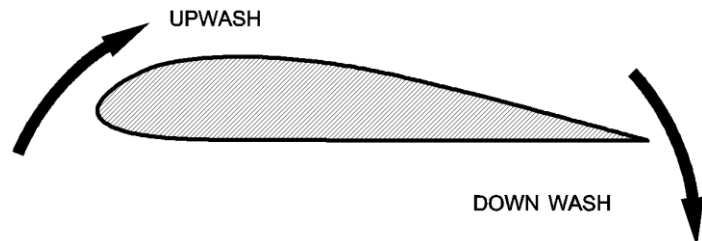

Figure 2-13 Upwash and Downwash

FINITE WING

Upwash and downwash are not equal on a finite wing. Not only does air flow up around the leading edge of a finite wing producing upwash, it also flows around the wingtips. Some of the high pressure air in the leading edge stagnation point flows spanwise to the wingtips instead of chordwise over the upper surface of the wing. Once it reaches the wingtips it flows around the wingtips and up to the upper surface of the wing. There, it combines with the chordwise flow that has already produced lift and adds to the downwash. Downwash approximately doubles by this process due to the spanwise airflow moving around the wingtip. The circular motion imparted to the increased downwash also results in the formation of wingtip vortices.

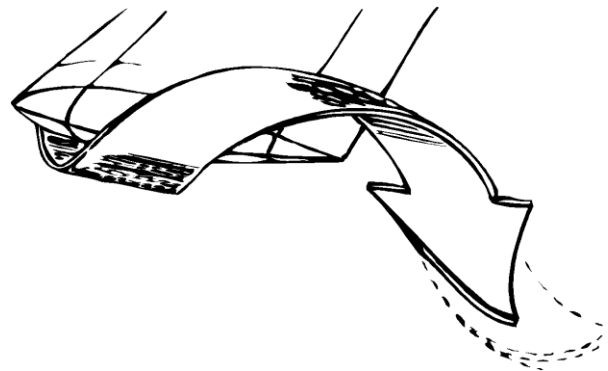

Figure 2-14 Finite Wing

Induced drag (D_I) is that portion of total drag associated with the production of lift. We can add the airflow at the leading edge and the airflow at the trailing edge of the wing in order to determine the average relative wind in the immediate vicinity of the wing. Since there is twice as much downwash as upwash near the wingtips of a finite wing, the average relative wind has a downward slant compared to the free airstream relative wind. The total lift vector will now be inclined aft, in order to remain perpendicular to the average relative wind. The total lift vector has components that are perpendicular and parallel to the free airstream relative wind. The perpendicular component of total lift is called effective lift. Because total lift is inclined aft, effective lift will be less than total lift. The parallel component of total lift is called induced drag since it acts in the same direction as drag and tends to retard the forward motion of the airplane.

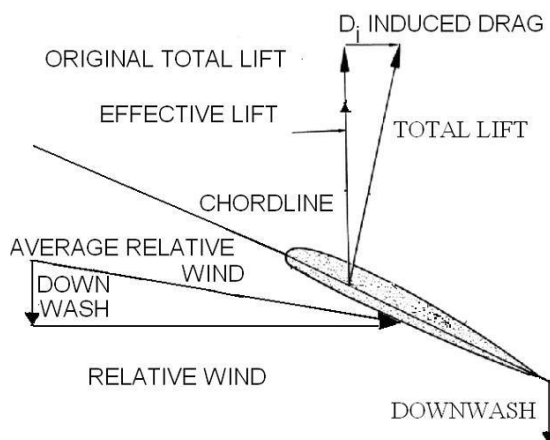

Figure 2-15 Induced Drag

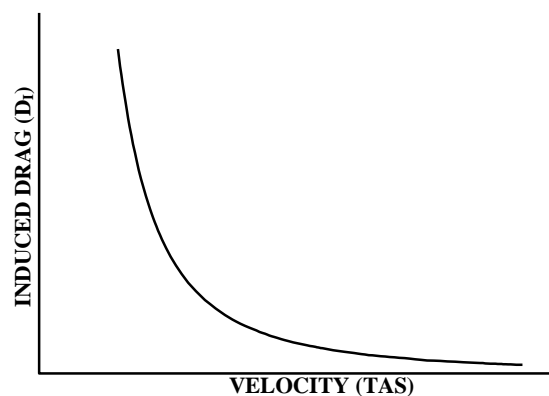

Figure 2-16 D_I vs. Velocity

The D_I equation is derived from the aerodynamic force equation and the assumption that weight equals lift in equilibrium level flight:

$$D_I = \frac{kL^2}{\rho V^2 b^2} = \frac{kW^2}{\rho V^2 b^2}$$

Analyzing the equation shows that increasing the weight of an airplane will increase induced drag, since a heavier airplane requires more lift to maintain level flight. Induced drag is reduced by increasing density (ρ), velocity (V), or wingspan (b). In level flight where lift is constant, induced drag varies inversely with velocity, and directly with angle of attack. Another method to reduce induced drag is to install devices that impede the spanwise airflow around the wingtip. These devices include winglets, wingtip tanks, and missile rails.

GROUND EFFECT

A phenomenon, known as **ground effect**, significantly reduces induced drag and increases effective lift when the airplane is within one wingspan of the ground. Because takeoffs and landings are conducted at low airspeeds, induced drag makes up a large portion of the total drag on the airplane. As an airplane nears the ground, the downwash at the trailing edge of the wing is unable to flow downward. The decrease in downwash allows the total lift vector to rotate forward, increasing effective lift and decreasing induced drag. When the aircraft is one wingspan above the ground (about 33 feet for T-6B) induced drag is reduced by only 1.4%, at one-fourth the wingspan, induced drag is reduced by 23.5%, and a maximum reduction of 60% occurs just prior to touchdown or after liftoff (Figure 2-17).

Because of the increased lift, it is possible to get airborne at an airspeed below normal flying speed. As an airplane takes off and leaves ground effect, induced drag increases and lift decreases, which could cause an altitude loss, possibly resulting in an unintentional gear-up landing.

Entering ground effect (during landing) increases effective lift and decreases induced drag by preventing the aft inclination of the lift vector. When the plane enters ground effect it will float down the runway if the pilot does not reduce thrust. The timing of the flare and power reduction when in ground effect is the most difficult aspect of the landing phase for most students.

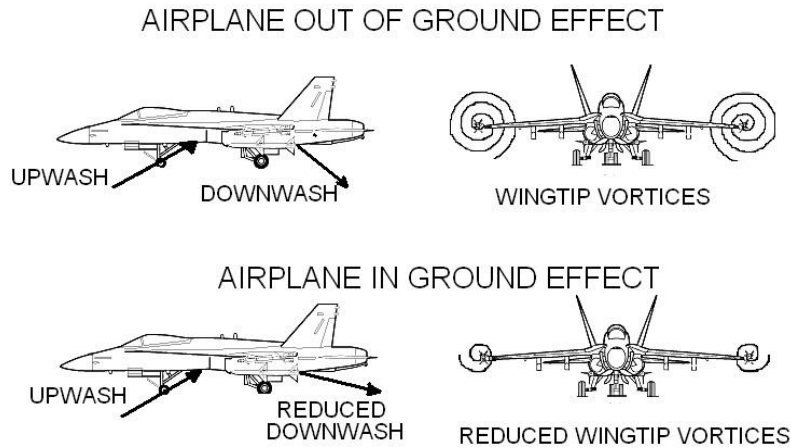

Figure 2-17 Ground Effect

TOTAL DRAG

Parasite and Induced drag can be added together to create a total drag curve. By superimposing both drag curves on the same graph, and adding the values of induced and parasite drag at each velocity, the total drag curve of Figure 2-18 is derived. The numbers 1, 4.4, and 17 depicted near the curve are reference values in the angle of attack scale. Note that they decrease as TAS increases. The drag curve depicted is particular to one aircraft at one weight, one altitude and one configuration. As weight, altitude and configuration change, the total drag curve will shift.

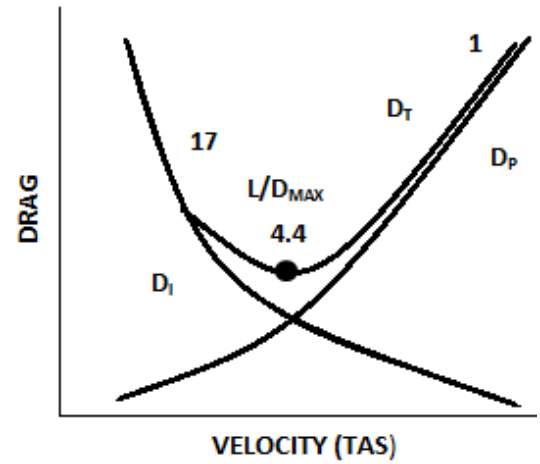

Figure 2-18 D_T vs. Velocity

LIFT TO DRAG RATIO

An airfoil is designed to produce lift, but drag is unavoidable. An airfoil that produced the desired lift but causes excessive drag is not desirable. The lift to drag ratio (L/D) is used to determine the efficiency of an airfoil. A high L/D ratio indicates a more efficient airfoil. L/D is calculated by dividing lift by drag. All terms except C_L and C_D cancel out:

$$\frac{L}{D} = \frac{\frac{1}{2} \rho V^2 S C_L}{\frac{1}{2} \rho V^2 S C_D} = \frac{C_L}{C_D}$$

A ratio of the coefficients at a certain angle of attack determines the L/D ratio at that angle of attack. The L/D ratio can be plotted against angle of attack along with C_L and C_D (Figure 2-19). The maximum L/D ratio is called L/D_{MAX} . Since angle of attack indicators are far less precise than airspeed indicators, pilots will typically fly an airspeed that corresponds to L/D_{MAX} AOA.

L/D_{MAX} AOA produces the minimum total drag. L/D_{MAX} is located at the bottom of the total drag curve. Any movement away from L/D_{MAX} will increase drag.

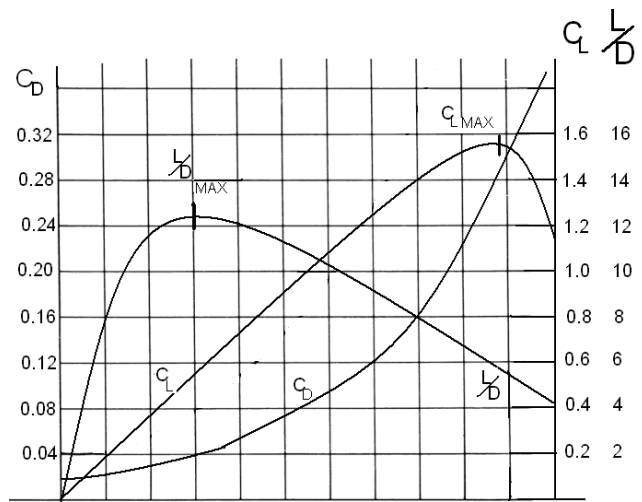

Figure 2-19 Lift to Drag Ratio

- At L/D_{MAX} AOA, parasite drag and induced drag are equal. At velocities below L/D_{MAX} , the airplane is affected primarily by induced drag, while at velocities above L/D_{MAX} , the airplane is affected primarily by parasite drag.
- L/D_{MAX} AOA produces the greatest ratio of lift to drag. Note that this is not the maximum amount of lift that can be produced, nor does it correspond to the airplanes maximum speed.
- L/D_{MAX} AOA is the most efficient angle of attack. Note that L/D is the efficiency of the wing, not the engine.
- An increase in weight or altitude will increase L/D_{MAX} airspeed, but not affect L/D_{MAX} or L/D_{MAX} AOA. A change in configuration may have a large effect on L/D_{MAX} and L/D_{MAX} airspeed. The effect of configuration on L/D_{MAX} AOA will depend on what causes the change (lowering landing gear or flaps, dropping external stores, speed brakes, etc.), and how much change is produced. This will be discussed more in the thrust and power section.

Thrust And Power

Thrust and Power Curves

This lesson makes the following assumptions:

1. Equilibrium flight on a standard day.
2. No afterburner for a turbojet.
3. Fixed pitch propeller for a turboprop.

Propeller Efficiency

The opposing force to drag is called thrust. In propeller driven aircraft the thrust, or power available, is determined by the propeller/engine output. **Thrust horsepower (THP)** is the output from the propeller and **shaft horsepower (SHP)** is the output from the engine. The ability of the propeller to convert SHP into THP is determined by the propeller efficiency (PE). Propeller efficiency is defined as:

$$PE = \frac{THP}{SHP}$$

Under ideal conditions, THP = SHP. However, due to friction in the reduction gearbox and drag on the propeller, efficiency is never 100%.

Fixed vs. Variable Pitch Propellers

All propellers become less efficient as altitude and/or temperature increase due to the decrease in density. The loss of thrust can be minimized in one of two ways: fixed pitch or variable pitch propellers.

Fixed pitch propellers have a constant blade angle and thrust is increased by increasing propeller RPM. **Variable pitch** propellers, also called constant speed propellers, keep propeller RPM constant and increase thrust by increasing blade angle of the propeller blades. The T-6B has a variable pitch, constant speed propeller that rotates at 2000 RPM.

At sea level, the PT6A-68 engine in the T-6B is flat rated at 1100 SHP. There is no direct indication of engine power available to the pilot. Because the T-6B uses a constant speed propeller, the torque the engine exerts on the propeller shaft is directly proportional to engine output power. Shaft torque (referred to as Torque on the instruments) is therefore used as the instrument indication of engine power.

Thrust Required

Total drag is the sum of parasite and induced drag. In equilibrium flight, thrust must equal drag, so the amount of thrust that is required to overcome drag can be found on the total drag curve. This amount of thrust is called **thrust required** (T_R), and is expressed in pounds. As with the drag curve, the thrust required curve is for one specific weight, altitude and configuration. L/D_{MAX} AOA is the point of minimum thrust required, and is obtained at some specific velocity. Flight at greater velocities requires a reduction in AOA (to maintain constant lift) and an increase in thrust (to match the increase in parasite drag). Flight at lower velocities requires an increase in AOA and an increase in thrust (to match the increase in induced drag).

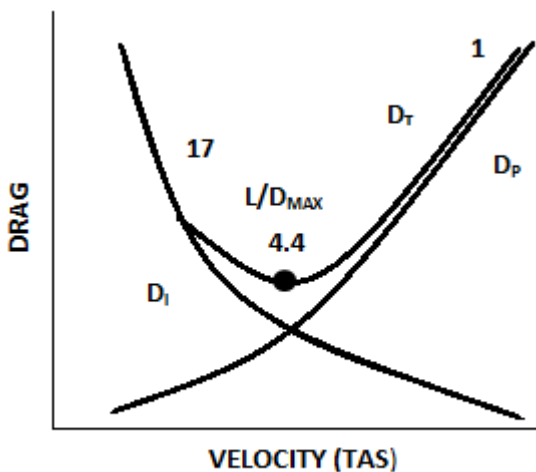

Figure 2-20 Total Drag

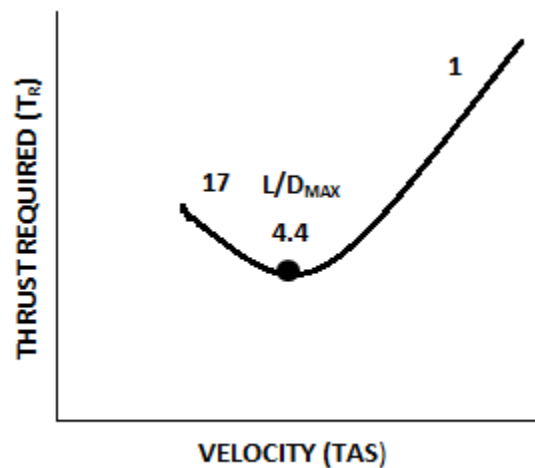

Figure 2-21 Thrust Required

Thrust Available

Thrust available (T_A) is the amount of thrust that the airplane's engines actually produce at a given throttle setting, velocity, and density. The most important factor is the throttle, also called the power control lever (PCL) in turboprops. Maximum engine output occurs at full throttle. As the throttle is retarded, thrust available decreases. Since the propeller can only accelerate the air to a maximum velocity, as the velocity of the incoming air increases, the air is accelerated less through the propeller, and thrust available decreases (Figure 2-22).

Turbojets do not suffer a decrease in thrust available with velocity because ram-effect overcomes the decreased acceleration (Figure 2-23). Therefore, T_A is approximated by a straight line.

For both turbojets and turboprops, as the density of the air decreases, thrust available decreases (Figures 2-35 and 2-37).

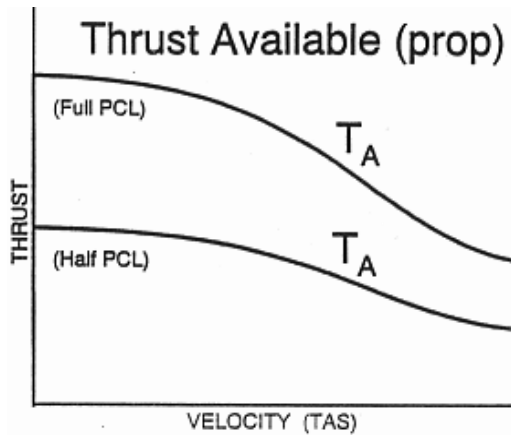

Figure 2-22 Thrust Available (Turboprop)

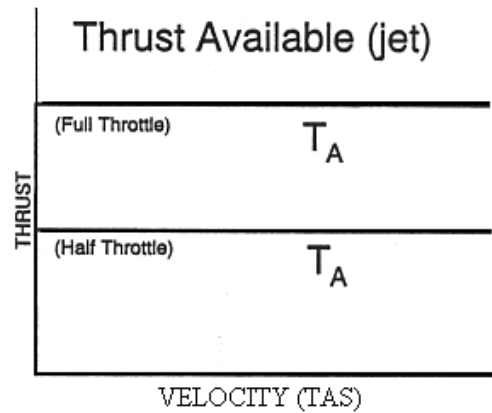

Figure 2-23 Thrust Available (Turbojet)

Power Required

Power is the rate of doing work, and work is a force times a distance. Power required (P_R) is the amount of power that is required to produce thrust required. P_R is the product of T_R and velocity (V). If V is expressed in knots, then the product of T_R and V must be divided by 325 to give power in units of horsepower. Thus, thrust horsepower only depends on thrust and velocity (Figure 2-24). For simplicity, we will use the term power (P) rather than thrust horsepower (THP) or shaft horsepower (SHP) unless there is a significant difference.

$$P_R = \frac{T_R \cdot V}{325}$$

To find L/D_{MAX} on the thrust required curve, draw a horizontal line tangent to the bottom of the curve. By applying the power equation to this line, the result is a straight line from the origin that is tangent to the power curve at L/D_{MAX} . Unlike on the T_R curve, L/D_{MAX} is not at the bottom of the P_R curve, but is to the right of the bottom of the curve. L/D_{MAX} still represents minimum total drag, but minimum P_R is to the left of L/D_{MAX} . It should be noted that the velocity and AOA for L/D_{MAX} are the same on the P_R curve as on the T_R curve.

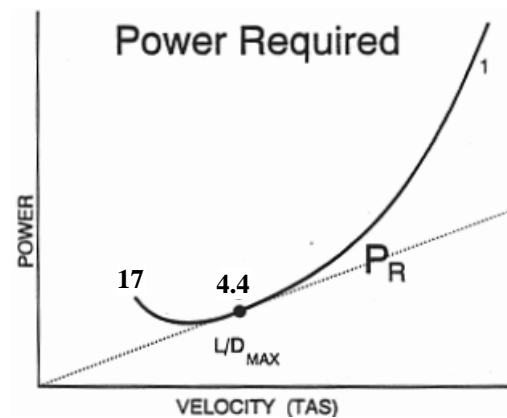

Figure 2-24 Power Required

Power Available

Power available (P_A) is the amount of power that the airplane's engines actually produce at a given throttle setting, velocity, and density. The most important factor is throttle setting. Maximum power available occurs at full throttle.

$$P_A = \frac{T_A \cdot V}{325}$$

As the pilot reduces the throttle setting, power available decreases. As velocity increases, power available for a jet will increase linearly. In a propeller driven aircraft, power available will initially increase, but will then decrease due to a decrease in thrust available (Figure 2-25 and Figure 2-26). As thrust available decreases with a decrease in density, power available will also decrease (Figures 2-36 and 2-38).

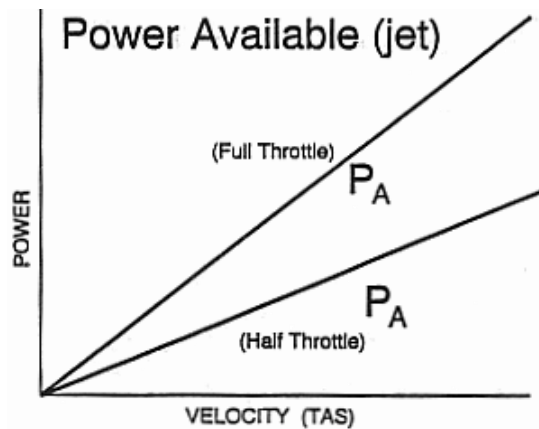

Figure 2-25 Power Available (Turbojet)

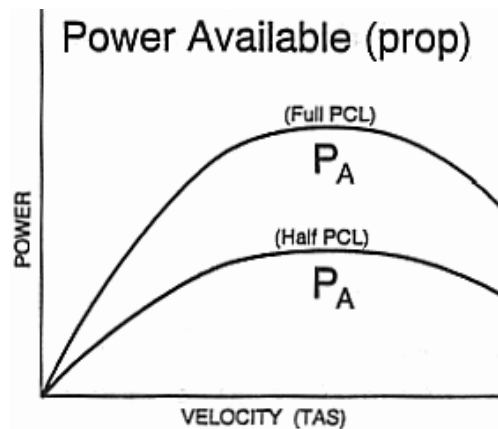

Figure 2-26 Power Available (Turboprop)

Thrust Excess and Power Excess

A comparison of the T_R and T_A curves on one graph allows one to predict airplane performance. To maintain equilibrium level flight, thrust available must equal thrust required for a specific angle of attack and velocity. This is depicted on a graph where the T_R and T_A curves cross. The right-hand point of equilibrium will produce the maximum velocity in level flight. This is the greatest airspeed that the aircraft can maintain without descending. It is approximately 255 KIAS at sea level for the T-6B.

A **thrust excess** (T_E) occurs if thrust available is greater than thrust required at a particular velocity. A positive T_E causes a climb, acceleration, or both, depending on angle of attack. A negative T_E is called a thrust deficit and has the opposite effect. Maximum thrust excess occurs at a full throttle setting, and is depicted on a graph where the distance between the T_R and T_A curves is greatest. For a turbojet, max thrust excess occurs at L/D_{MAX} (Figure 2-27). For a turboprop, max thrust excess occurs at a velocity less than L/D_{MAX} (Figure 2-28).

$$T_E = T_A - T_R$$

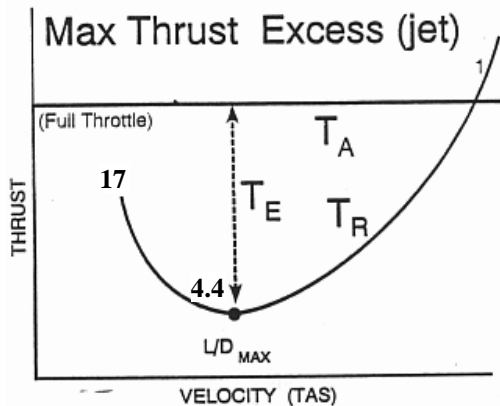

Figure 2-27 Thrust Excess (Turbojet)

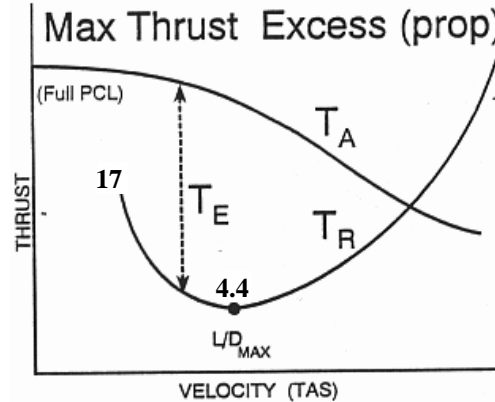

Figure 2-28 Thrust Excess (Turboprop)

Power excess (P_E) is calculated in a similar manner as T_E and will also produce a climb, acceleration, or both. Likewise, a power deficit will cause a decent, a deceleration, or both. For a turbojet, maximum power excess occurs at a velocity greater than L/D_{MAX} (Figure 2-29). For a turboprop, max power excess occurs at L/D_{MAX} (Figure 2-30). It is important to note that maximum power excess is achieved at a greater velocity and a lower angle of attack than maximum thrust excess. It should also be noted that a power excess cannot exist if thrust excess is zero.

$$P_E = P_A - P_R$$

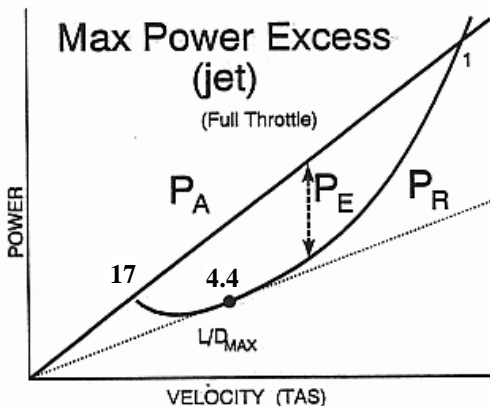

Figure 2-29 Power Excess (Turbojet)

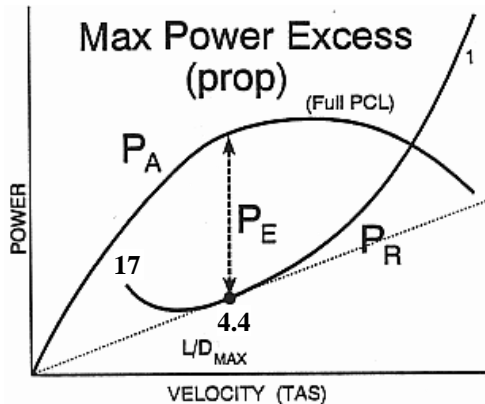

Figure 2-30 Power Excess (Turboprop)

Factors Affecting T_E and P_E

Weight

If an airplane is in equilibrium level flight at a constant angle of attack, an increase in weight requires an increase in lift. In order to increase lift at a constant AOA, velocity must increase.

$$W = L = \frac{1}{2} \rho V^2 SC_L$$

A higher velocity and more lift increases both parasite and induced drag; therefore, total drag increases. The net result is the T_R curve shifts up and to the right (Figure 2-31).

$$T_R = D = \frac{1}{2} \rho V^2 SC_D$$

Power required (P_R) is similarly affected by weight. An increase in weight requires an increase in velocity and a corresponding increase in thrust required (T_R) at a specific angle of attack. Since P_R is a function of thrust required and velocity, an increase in weight will result in an increase in power required. The net result of an increase in weight is that the T_R and P_R curves will shift up and right (Figure 2-32).

$$P_R = \frac{T_R \cdot V}{325}$$

Weight changes have no effect on thrust available or power available, as they do not affect the engine. As weight increases, thrust required and power required increase while thrust available and power available remain constant. Thus thrust excess and power excess decrease at every AOA and velocity.

$$T_E = T_A - T_R$$

$$P_E = P_A - P_R$$

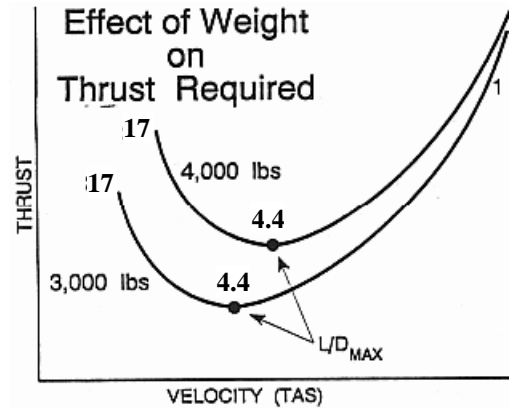

Figure 2-31 Effect of Weight on T_R

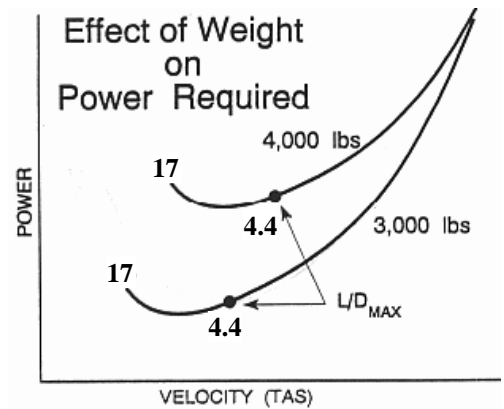

Figure 2-32 Effect of Weight on P_R

Altitude

If an airplane weighs 5,000 lbs at sea level, it requires 5,000 lbs of lift. It will weigh 5,000 lbs and require the same lift at any higher altitude as well. Since density has decreased, velocity must increase to maintain 5,000 lbs of lift. Thus as altitude increases, the T_R curve shifts to the right.

$$\overline{W} = \overline{L} = \frac{1}{2} \rho V^2 S C_L$$

The decrease in density is exactly offset by an increase in velocity to maintain constant lift for any given AOA, so the dynamic pressure felt by the airfoil remains constant. With no change in dynamic pressure as lift is maintained at a higher altitude for any fixed AOA, drag and T_R remain constant. Thus as altitude increases, the thrust required curve shifts to the right, but not up (Figure 2-33).

$$\overline{T}_R = \overline{D} = \frac{1}{2} \rho V^2 S C_D$$

Since P_R is the product of T_R and velocity, the P_R curve will shift to the right as altitude increases and the T_R curve shifts to the right. Because the same thrust is multiplied by a higher velocity, the P_R curve will move up as well (Figure 2-34).

$$P_R = \overline{T}_R \cdot V$$

Maximum engine output decreases with a reduction in air density. Thus, both T_A and P_A decrease at higher altitudes. Thrust excess will decrease with an increase in altitude due to the decrease in thrust available. Power excess will decrease with an increase in altitude because power available decreases and power required increases.

$$T_E = T_A - T_R$$

$$P_E = P_A - P_R$$

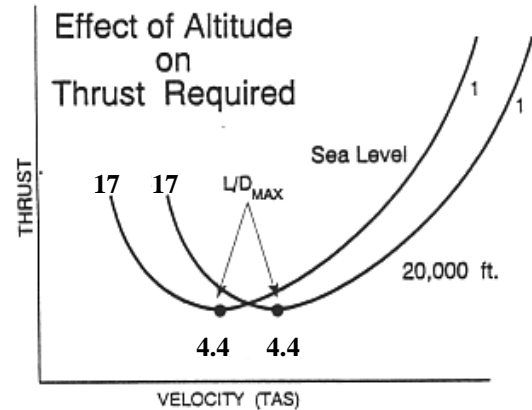

Figure 2-33 Effect of Altitude on T_R

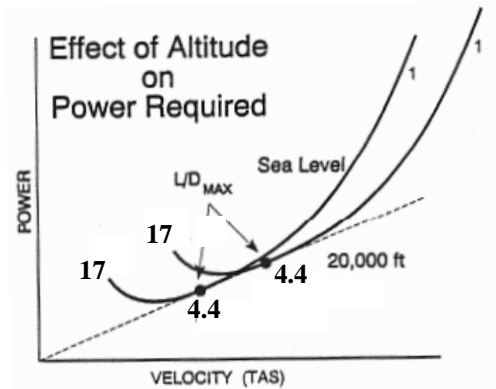

Figure 2-34 Effect of Altitude on P_R

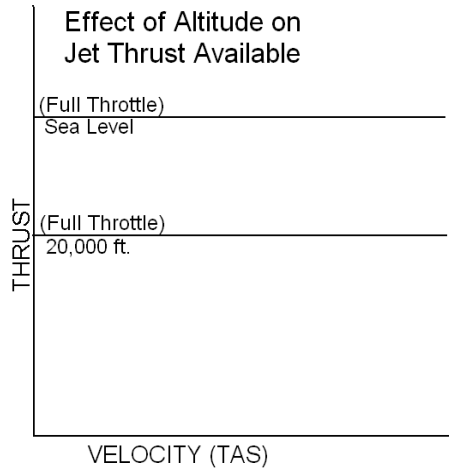

Figure 2-35 Effect of Altitude on T_A (Turbojet)

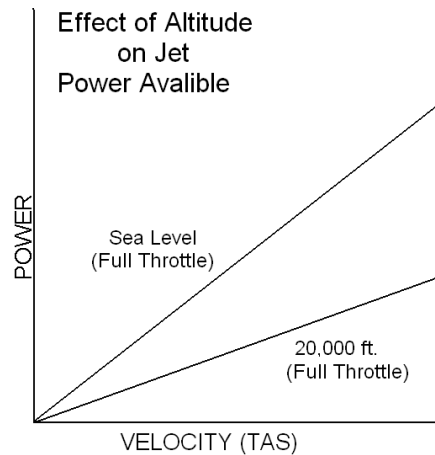

Figure 2-36 Effect of Altitude on P_A (Turbojet)

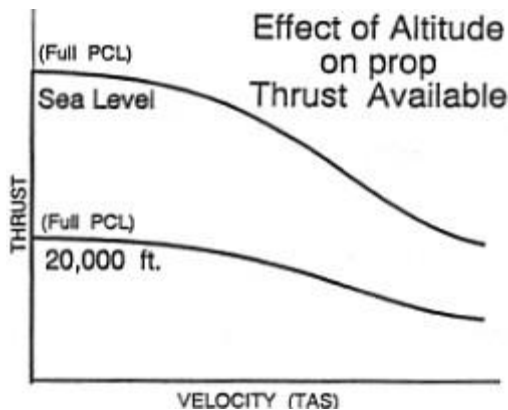

Figure 2-37 Effect of Altitude on T_A (Turboprop)

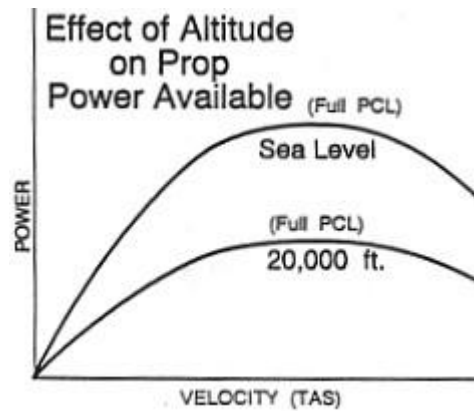

Figure 2-38 Effect of Altitude on P_A (Turboprop)

Configuration

Lowering the landing gear has no effect on the lift produced by the wing, so at any AOA no change in velocity is required to maintain lift. Lowering the landing gear does, however, dramatically increase parasite drag, which causes T_R and P_R to increase. Thus more thrust and power are required to maintain altitude for any given AOA and velocity, so both the T_R and P_R curves shift up.

$$T_R = D = \frac{1}{2} \rho V^2 S C_D$$

The landing gear has no effect on the engine, so T_A and P_A are not affected. Thrust and power excess will decrease with deployment of the landing gear because T_R and P_R increase.

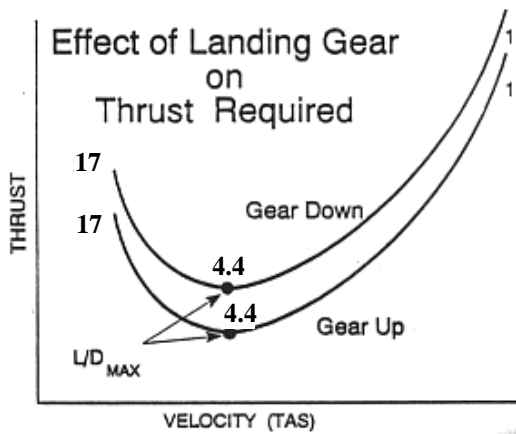

Figure 2-39 Effect of Landing Gear on T_R

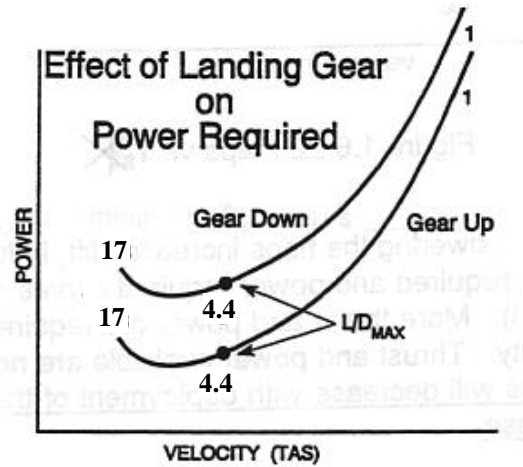

Figure 2-40 Effect of Landing Gear on P_R

Lowering the flaps increases the coefficient of lift, allowing the aircraft to fly at a lower velocity to produce enough lift to offset weight, so the T_R curve shifts left.

$$\overline{W} = \overline{L} = \frac{1}{2} \rho \overline{V}^2 \overline{S} C_L$$

While increasing lift, the flaps greatly increase parasite drag. Induced drag also increases. Thus total drag and thrust required increase. Viewed another way using the drag equation, the decrease in velocity is more than offset by the increase in the coefficient of drag, causing thrust required to increase.

$$\overline{T}_R = \overline{D} = \frac{1}{2} \rho \overline{V}^2 \overline{S} C_D$$

The net effect of lowering flaps is to shift both the T_R and P_R curves up and to the left. More thrust and power are required to maintain altitude for any given velocity.

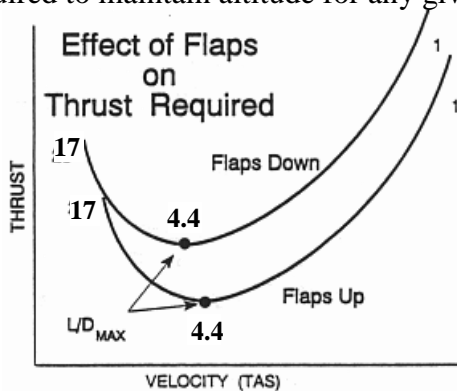

Figure 2-41 Effect of Flaps on T_R

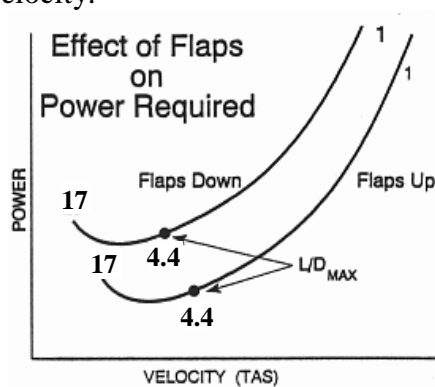

Figure 2-42 Effect of Flaps on P_R

As with the landing gear, flaps have no effect on the engine, so T_A and P_A are not affected. Thrust and power excess will decrease with deployment of the flaps because thrust and power required increase.

Aircraft Control Systems

Control Surfaces

To maneuver, the pilot must redirect the forces acting on the airplane. Control surfaces allow the pilot to change the amount of lift of the airfoil to which they are attached and create different airplane motions, such as yaw, pitch, and roll.

The elevator is attached to the trailing edge of the horizontal stabilizer, and controls the pitching moment around the lateral axis. Moving the control stick forward causes the elevator to move down. When the elevator moves downward, it increases the camber and produces more lift, forcing the tail of the airplane up and pitching the nose down. The opposite movements are used to pitch the aircraft up. Some airplanes move the entire horizontal stabilizer. This is called a stabilator and is used on the F-15 and F/A-18.

The ailerons are attached to the outboard trailing edges of the wings, and produce a rolling moment. Ailerons move in unison in opposite directions. If the control stick is pushed left, the left aileron raises creating a negative camber on left wing, producing lift in the downwards direction. At the same time, the right aileron lowers increasing the camber of the right wing, producing more lift. The difference in lift between the wings causes the plane to roll left (Figure 2-43). As long as the ailerons are deflected the airplane will continue to roll. When the stick is centered, the airplane will stop rolling, and remain at that bank angle until the stick is deflected again.

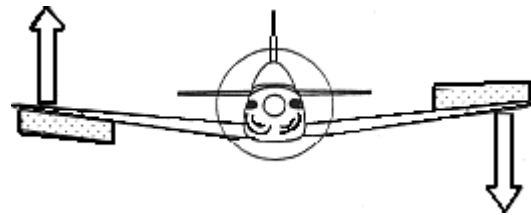

Figure 2-43 Aileron Operation During a Roll to the Left

Spoilers may be attached to the wing's upper surface to provide roll control on some aircraft. Spoilers disrupt the airflow over the top of the wing in order to decrease the lift on the wing and cause the wing to roll downward. Spoilers may be used in conjunction with ailerons and/or stabilators.

The rudder is attached to the trailing edge of the vertical stabilizer, and produces a yawing moment. Stepping on the right rudder pedal moves the rudder to the right, creating an airfoil positively cambered and creating lift causing the tail to "fly" left and yawing the airplane's nose to the right.

Trim Tabs

Trim tabs are attached to the trailing edge of each control surface and have two functions. The primary purpose of trim tabs is to trim. Trimming reduces the force required to hold control surfaces in a position necessary to maintain a desired flight attitude. Trim allows the pilot to fly virtually hands off, momentarily freeing the pilot's hands for other tasks, such as tuning radios or folding charts. The second purpose of trim tabs is to provide artificial feel.

If the pilot pulls back on the control stick, the elevator is deflected up so that the nose of the airplane pitches up. The airflow around the horizontal stabilizer creates a downward force on the elevator that acts at a distance (moment arm) from the hinge line (Figure 2-44). This creates a moment that tends to move the elevator back in line with the horizontal stabilizer. In order to keep the airplane's nose up, the pilot must exert enough back pressure on the control stick to overcome the moment created by the elevator's force. By moving the trim tab in the opposite direction as the control surface, a small force is created by the trim tab in the opposite direction.

Since this small force has a greater moment arm, it creates a moment that exactly opposes the moment created on the elevator.

Once the sum of the moments is zero, the elevator will remain in place until the pilot moves the control stick again. For trimming, trim tabs must always be moved in the opposite direction as the control surface. If the pilot moves a control away from its trimmed position, and then releases it, the trim tabs will cause the control surface to move back to its trimmed position. If the pilot moves the control surface and wants it to remain in place, the control surface must be re-trimmed.

T-6B trim settings are changed by adjusting the trim switches on the control stick (aileron/elevator) and on the PCL (Rudder). There are no aileron trim tabs that can be adjusted in flight on the T-6B.

When the T-6B aileron trim switch is adjusted, the ailerons themselves actually move. T-6B rudder trim is automatically adjusted during flight by the trim aid device (TAD). Rudder trim compensates for prop wash and torque, which vary with power. Elevator trim is adjusted to maintain various angles of attack while changing airspeed. A general rule is: right rudder trim is required for power increases and slower airspeeds; left rudder trim is required for power reductions and faster airspeeds (power changes take precedence at low speeds). Elevator trim is adjusted up at slower speeds and down at higher speeds (Figure 2-45).

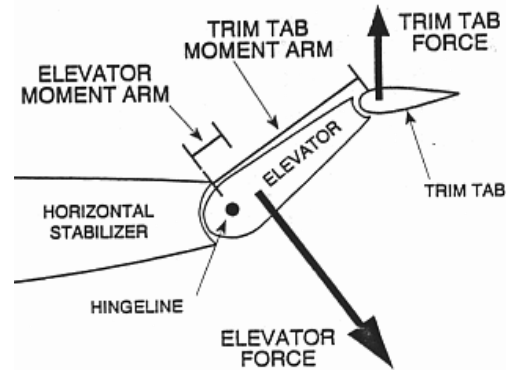

Figure 2-44 Trim Tab Operation

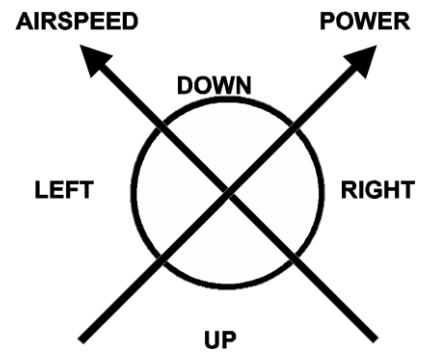

Figure 2-45 Rudder and Elevator Trim

Control Balancing

The forces that act at the control surface's center of gravity and aerodynamic center must be balanced around the hinge line in order to regulate control pressure, prevent control flutter, and provide control-free stability.

Control-free is the situation where the controls are not being manipulated by the pilot (hands off). Aerodynamic balance concerns balancing the forces that act at the aerodynamic center. Mass balance concerns balancing the forces that act at the center of gravity.

Aerodynamic balance is used to keep control pressures associated with higher velocities within reasonable limits. As the trailing edge of the control surface is deflected in one direction, the leading edge deflects into the airstream forward of the hinge line (Figure 2-46). The force on the leading edge creates a moment that reduces the force required to deflect the control surface, so the pilot may control the airplane more easily. For aerodynamic balance, the T-6B uses shielded horns on the elevator and rudder (Figure 2-47).

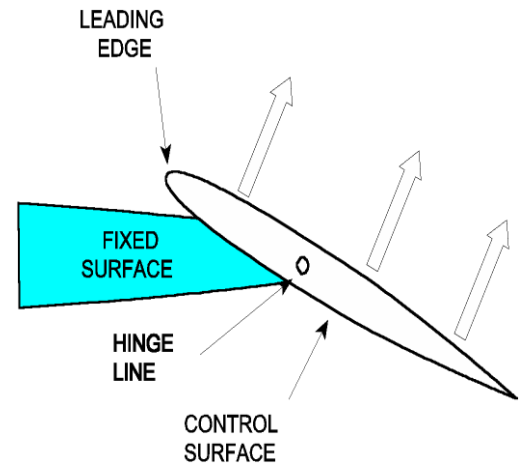

Figure 2-46 Aerodynamic Balance

The relationship of the control surface CG to the hinge line will determine the control-free stability of the airplane. The **hinge line** is the point around which control surfaces are balanced in the T-6B. Stability is more desirable in transport and bomber type airplanes and therefore the control surface CG is usually located forward of the hinge line. This keeps the control surface aligned with the fixed surface ahead of it when struck by gusts from turbulence. For high performance airplanes, the CG is located on or aft of the hinge line. With the CG aft of the hinge line, the control tends to float into the relative wind and cause a greater displacement which allows a faster response to control action and makes the airplane more maneuverable. To gain a balance between control response and stability, the T-6B control surfaces CGs are located on the hinge line. To locate the CG on the hinge line, weights are placed inside the control surface in the area forward of the hinge line (shielded horn and leading edges). This technique is called **mass balancing**. Mass balancing of the T-6B ailerons is achieved by placing weights in the overhang.

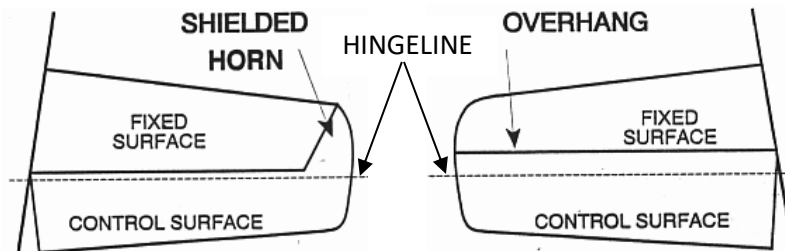

Figure 2-47 Aerodynamic Balance on a Horizontal Stabilizer

Control Feel

There are several basic types of control systems used to move the control surfaces: **conventional**, **power-assisted**, and **full power** (fly-by-wire).

In **conventional** controls the forces applied to the stick and rudder pedals are transferred directly to the control surfaces via push-pull tubes, pulleys, cables and levers. If an external force moves the control surfaces, the stick or rudder pedal will move in the cockpit. This action is called reversibility and gives the pilot feedback.

Feedback is the force that the pilot feels in his hands or feet for a given deflection of the stick or rudder pedals. Without feedback the pilot would tend to over control and possibly overstress the airplane. The T-6B uses conventional controls.

Power-boosted controls have mechanical linkages with hydraulic, pneumatic, or electrical boosters to assist the pilot in moving the controls in the same way power steering assists a car driver. The degree to which the controls are boosted varies depending upon the mission and design of the airplane. These systems have some reversibility, and the pilot receives some control feel through the cockpit controls. If the boost system fails, the pilot can still control the airplane, although the control forces will be greatly increased.

With a **full-power** or fly-by-wire control system, the pilot has no direct connection with the control surfaces. The controls of a full power system are connected to hydraulic valves or electrical switches which control the movement of the control surfaces. The fly-by-wire system uses computer commands to displace the controls. These systems are not reversible. Movement of the control stick causes the control surfaces to move, but movement of the control surfaces will not cause the control stick to move. Since these systems are not reversible, they require an artificial means of producing control feel.

Artificial feel is the use any device used to create or enhance control feedback under various flight conditions such as airspeed and acceleration changes. The T-6B uses trim tabs, a bobweight and 2 downsprings to provide artificial feel to the pilot.

There are three types of trim tabs that provide artificial feel: servo, anti-servo, and neutral.

Servo trim tabs move in the opposite direction of the control surface, helping the pilot deflect the control surface and making the airplane easier to maneuver (Figure 2-48). Servo trim tabs are generally found on ailerons. The T-6B uses neutral trim tabs on the ailerons.

Anti-servo trim tabs move in the same direction, requiring more force to hold the control surface at full deflection. Artificial feel is provided in the T-6B rudder by an anti-servo trim tab. In the T-6B, when the rudder is displaced, the anti-servo trim tab moves in the same direction at a faster rate (Figure 2-49). The more that a rudder pedal is pressed, the greater the resistance that the pilot will feel.

Because trim tabs do not provide the desired type of artificial feel, the T-6B elevator uses a **neutral trim tab** that maintains a constant angle to the elevator when the control surface is deflected (Figure 2-50). The elevator uses both a bobweight, 2 downsprings and a neutral trim tab to provide the pilot with some artificial feel (Figure 2-51). The downsprings increase the force required to pull the stick aft at low airspeeds and the bobweight increases the force required to pull the stick aft during maneuvering flight.

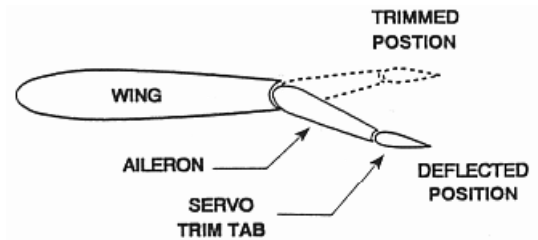

Figure 2-48 Servo Trim Tab

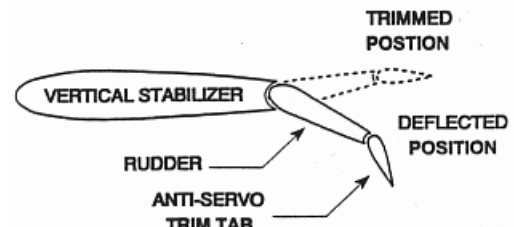

Figure 2-49 Anti-Servo Trim Tab

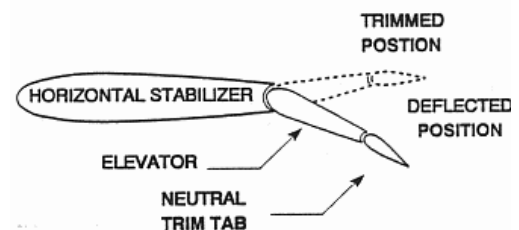

Figure 2-50 Neutral Trim Tab

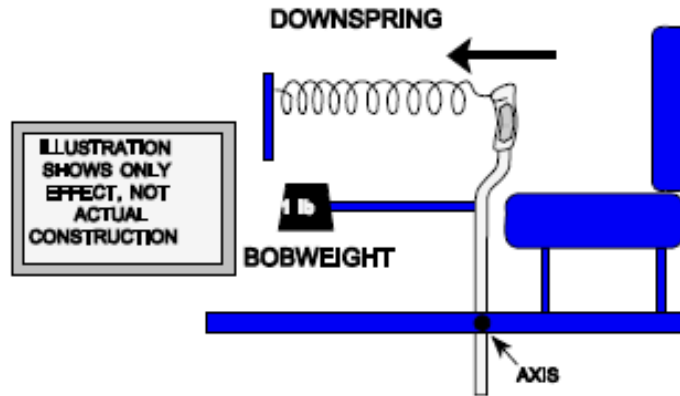

Figure 2-51 Elevator Artificial Feel

Historical Note

The problem of balancing stability and maneuverability has been around since flight began. It is interesting to note that the Wright brothers fully recognized this problem. They were the first to understand the need for positive roll control, such as ailerons. The Wright brothers were the first to demonstrate the use of ailerons with rudder for producing a coordinated turn (no sideslip). Interestingly they made their airplanes highly maneuverable by designing them to be statically unstable. Since then, most airplanes have been statically stable and relatively easy to fly.

ASSIGNMENT SHEET 2-2-3

LIFT PRODUCTION AND DRAG REVIEW

A. INTRODUCTION

This lesson is a continuation of aerodynamic principles from Lesson 2.1. Definitions of lift, weight, thrust and drag and how each relates to one another on an aircraft will be presented. Basic configuration principles and effects on lift production will also be discussed.

B. ENABLING OBJECTIVES

C. STUDY ASSIGNMENT

1. Review Naval Aviation Fundamentals, NAVAVSCOLSCOM-SG-200 Unit 2, Chapter 2
2. Read Naval Aviation Fundamentals, NAVAVSCOLSCOM-SG-200 Unit 2, Chapter 3

D. STUDY QUESTIONS

1. Aerodynamic force is the _____.
 - a. force that is perpendicular to the relative wind
 - b. leading edge stagnation point
 - c. result of pressure and friction distribution over an airfoil
 - d. force that is parallel to the relative wind

2. The component of aerodynamic force that acts parallel to the relative wind is _____.
 - a. parasite drag
 - b. lift
 - c. drag
 - d. angle of attack

3. A _____ airfoil produces lift at zero degrees angle of attack.
 - a. symmetric
 - b. tapered
 - c. dihedral
 - d. positively cambered

4. L/D_{MAX} is the point where _____.
 - a. drag is the greatest
 - b. lift is the greatest
 - c. the ratio of lift to drag is the greatest
 - d. the stall angle of attack is reached

5. Total drag is composed of _____.
 - a. parasite and induced drag
 - b. form and interference drag
 - c. thrust and lift
 - d. upwash and downwash

6. Parasite drag is _____.
 - a. the component of drag associated with the production of lift
 - b. minimized by installing winglets, wingtip fuel tanks or missile rails
 - c. greatest at low airspeeds
 - d. made up of form, friction, and interference drag

7. Maximum excess power for a propeller-driven aircraft occurs _____ L/D_{MAX} .
 - a. at an airspeed below
 - b. at
 - c. at an airspeed above
 - d. independent of

8. As altitude increases, power available _____.
 - a. increases
 - b. remains the same
 - c. decreases
 - d. is equal to thrust available

9. A _____ trim tab will increase the force required to move a control surface to full deflection.
 - a. servo
 - b. neutral
 - c. anti-servo
 - d. balanced

Additional Aero I Review Questions:

1. What are the differences between true airspeed (TAS), groundspeed (GS), indicated airspeed (IAS), calibrated airspeed (CAS), and equivalent airspeed (EAS)?
2. What is the difference between a symmetric and a cambered airfoil?
3. What are the definitions for angle of attack, pitch angle, and angle of incidence?
4. Why does parasite drag increase and induced drag decrease with increased airspeed?
5. When does maximum excess thrust occur for any aircraft in-flight?
6. Does the maximum power excess for a prop aircraft occur at a velocity slower than, equal to, or faster than L/D_{MAX} airspeed?

ANSWERS:

- 1.C 6. D
- 2.C 7. B
- 3.D 8. C
- 4.C 9. C
- 5.A

ADDITIONAL REVIEW ANSWERS:

- 1. a. Indicated airspeed (IAS): Read on airspeed indicator; measure of dynamic pressure
b. Calibrated airspeed (CAS): IAS corrected for instrument error
c. Equivalent airspeed (EAS): CAS corrected for compressibility; speed at sea level on a std day
d. True airspeed (TAS): EAS corrected for density; speed relative to the air mass
e. Groundspeed (GS): TAS corrected for wind; speed relative to the ground
- 2. a. Symmetric: MCL and chord line are the same
b. Positively cambered airfoil: MCL above chord line
- 3. a. Angle of attack (AOA): Angle between relative wind and wing chord line
b. Pitch angle: Angle between the horizon and aircraft longitudinal axis
c. Angle of incidence: Preset angle between wing chord line and aircraft longitudinal axis
- 4. a. Parasite drag is dependent upon the amount of air flowing over, around, and between surfaces. When airflow increases, parasite drag increases.
b. Induced drag is created by the production of lift and is proportional to aircraft AOA. Unless the aircraft is in high G flight, AOA decreases with increased airspeed, therefore induced drag decreases.
- 5. a. Maximum thrust excess occurs when the difference between thrust available and thrust required (total drag) is the greatest.
b. Max thrust excess for a propeller-driven aircraft occurs at an airspeed slower than L/D_{MAX} airspeed.
- 6. a. Maximum power excess occurs when the difference between power available and power required (total drag X velocity) is the greatest.
b. Max power excess for a propeller-driven aircraft occurs at L/D_{MAX} airspeed.

OUTLINE SHEET 2-3-1

STALLS

A. INTRODUCTION

This lesson covers fundamental information on the aerodynamic causes and characteristics of aircraft stalls. Factors affecting stalls, anti-stall devices, and T-6 stalls are also discussed.

B. ENABLING OBJECTIVES

- 3.1 DEFINE the boundary layer, in a classroom, in accordance with Naval Aviation Fundamentals, NAVAVSCOLSCOM-SG-200
- 3.2 DESCRIBE the different types of flow within the boundary layer, in a classroom, in accordance with Naval Aviation Fundamentals, NAVAVSCOLSCOM-SG-200
- 3.3 DESCRIBE boundary layer separation, in a classroom, in accordance with Naval Aviation Fundamentals, NAVAVSCOLSCOM-SG-200
- 3.4 DEFINE CL MAX AOA, in a classroom, in accordance with Naval Aviation Fundamentals, NAVAVSCOLSCOM-SG-200
- 3.5 DEFINE stall, in a classroom, in accordance with Naval Aviation Fundamentals, NAVAVSCOLSCOM-SG-200
- 3.6 EXPLAIN how a stall occurs, in a classroom, in accordance with Naval Aviation Fundamentals, NAVAVSCOLSCOM-SG-200
- 3.7 IDENTIFY the aerodynamic parameters causing a stall, in a classroom, in accordance with Naval Aviation Fundamentals, NAVAVSCOLSCOM-SG-200
- 3.8 COMPARE power-on and power-off stalls, in a classroom, in accordance with Naval Aviation Fundamentals, NAVAVSCOLSCOM-SG-200
- 3.9 DESCRIBE the order of losing control effectiveness approaching a stall in the T-6B, in a classroom, in accordance with Naval Aviation Fundamentals, NAVAVSCOLSCOM-SG-200
- 3.10 EXPLAIN the difference between true and indicated stall speed, in a classroom, in accordance with Naval Aviation Fundamentals, NAVAVSCOLSCOM-SG-200

- 3.11 EXPLAIN the effects of gross weight, altitude, load factor and maneuvering on stall speed, given the stall speed equation, in a classroom, in accordance with Naval Aviation Fundamentals, NAVAVSCOLSCOM-SG-200
- 3.12 STATE the purpose of using high lift devices, in a classroom, in accordance with Naval Aviation Fundamentals, NAVAVSCOLSCOM-SG-200
- 3.13 DESCRIBE how different high lift devices affect the values of CL, CL MAX, and CL MAX AOA, in a classroom, in accordance with Naval Aviation Fundamentals, NAVAVSCOLSCOM-SG-200
- 3.14 DESCRIBE devices used to control boundary layer separation, in a classroom, in accordance with Naval Aviation Fundamentals, NAVAVSCOLSCOM-SG-200
- 3.15 DESCRIBE devices used to change the camber of an airfoil, in a classroom, in accordance with Naval Aviation Fundamentals, NAVAVSCOLSCOM-SG-200
- 3.16 DESCRIBE methods of stall warning used in the T-6B, in a classroom, in accordance with Naval Aviation Fundamentals, NAVAVSCOLSCOM-SG-200
- 3.17 DESCRIBE the stall tendency of the general types of wing planforms, in a classroom, in accordance with Naval Aviation Fundamentals, NAVAVSCOLSCOM-SG-200
- 3.18 DESCRIBE the various methods of wing tailoring, including geometric twist, aerodynamic twist, stall strips, and stall fences, in a classroom, in accordance with Naval Aviation Fundamentals, NAVAVSCOLSCOM-SG-200

C. TOPIC OUTLINE

- 1. Introduction
- 2. This Lesson Topic
- 3. Stall Aerodynamics
- 4. Stall Characteristics
- 5. Factors Affecting Stall Speed
- 6. High Lift Devices
- 7. T-6B Stalls
- 8. Stall Pattern / Wing Design
- 9. Summary and Review
- 10. Application
- 11. Assignment

INFORMATION SHEET 2-3-2

STALLS

A. INTRODUCTION

This lesson covers fundamental information on the aerodynamic causes and characteristics of aircraft stalls. Factors affecting stalls, anti-stall devices, and T-6 stalls are also discussed.

B. REFERENCES

1. Aerodynamics for Naval Aviators, NAVAIR 00-80T-80
2. Introduction to the Aerodynamics of Flight, NASA SP-367
3. T-6 Joint Primary Pilot Training, AETC / CNATRA Syllabus P-V4A-J NATOPS Flight Manual

C. INFORMATION

THE BOUNDARY LAYER

In the preceding discussion of lift, it was shown that when air flows across any surface, friction develops. The air immediately next to the surface slows to near zero velocity as it gives up kinetic energy to friction. As a viscous fluid resists flow or shearing, the adjacent layer of air is also slowed. Succeeding streamlines are slowed less, until eventually some outer streamline reaches the free airstream velocity. The **boundary layer** is that layer of airflow over a surface that demonstrates local airflow retardation due to viscosity. It is usually no more than 1mm thick (the thickness of a playing card) at the leading edge of an airfoil, and grows in thickness as it moves aft over the surface. The boundary layer has two types of airflow.

In **laminar flow**, the air moves smoothly along in streamlines. A laminar boundary layer produces very little friction, but is easily separated from the surface.

In **turbulent flow**, the streamlines break up and the flow is disorganized and irregular. A turbulent boundary layer produces higher friction drag than a laminar boundary layer, but adheres better to the upper surface of the airfoil, delaying boundary layer separation.

Any object that moves through the air will develop a boundary layer that varies in thickness according to the type of surface. The type of flow in the boundary layer depends on its location on the surface. The boundary layer will be laminar only near the leading edge of the airfoil. As the air flows aft, the laminar layer becomes turbulent. The turbulent layer will continue to increase in thickness as it flows aft (Figure 9-1).

Air flows aft from the leading edge (high static pressure) of the airfoil towards the point of maximum thickness (low static pressure) resulting in a **favorable pressure gradient** assisting the boundary layer in adhering to the surface by maintaining its high kinetic energy. As the air flows aft from the point of

maximum thickness (lower static pressure) toward the trailing edge (higher static pressure), it encounters an **adverse pressure gradient** which impedes the flow of the boundary layer.

The adverse pressure gradient is strongest at high lift conditions and at high angles of attack in particular. If the boundary layer does not have sufficient kinetic energy to overcome the adverse pressure gradient, the lower levels of the boundary layer will stagnate. The boundary layer will then separate from the surface, and airflow along the surface aft of the separation point will be reversed. Aft of the separation point, the low static pressure that produced lift is replaced by a turbulent wake.

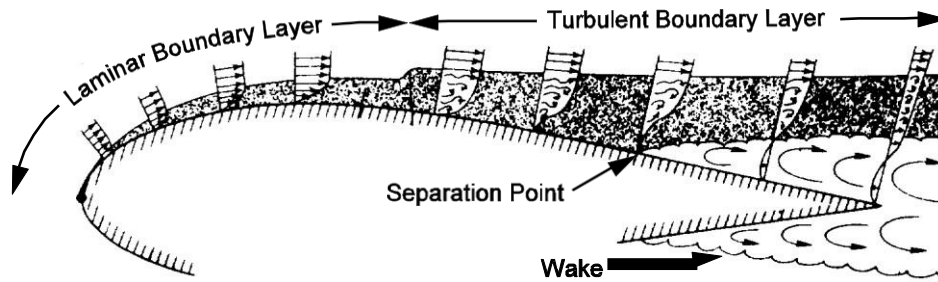

Figure 3-1 Boundary Layer Separation

If the separation point moves forward enough close to the leading edge, the net suction on the top of the airfoil will decrease and a decrease in C_L will occur, resulting in a stall. The angle of attack beyond which C_L begins to decrease is $C_{L_{max}}$ AOA. Even at low angles of attack there will be a small adverse pressure gradient behind the point of maximum thickness, but it is insignificant compared to the kinetic energy in the boundary layer until $C_{L_{max}}$ AOA is approached.

Figure 3-1 shows the boundary layer attached at a normal AOA. The point of separation remains essentially stationary near the trailing edge of the wing, until AOA approaches $C_{L_{max}}$ AOA. The separation point then progresses forward as AOA increases, eventually causing the airfoil to stall. At high angles of attack the airfoil is similar to a flat plate being forced through the air; the airflow simply cannot conform to the sharp turn. Note that the point where stall occurs is dependent upon AOA and not velocity.

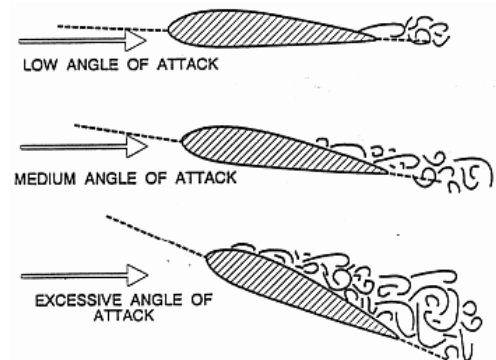

Figure 3-2 Progression of Separation Point Forward with Increasing AOA

A **stall** is a condition of flight in which an increase in AOA results in a decrease in C_L . In Figure 3-3 C_L increases linearly over a large range of angles of attack then reaches a peak and begins to decrease. The highest value of C_L is referred to as $C_{L_{max}}$, and any increase in AOA beyond $C_{L_{max}}$ AOA produces a decrease in C_L . Therefore, $C_{L_{max}}$ AOA is known as the **stalling angle of attack** or critical angle of attack, and the region beyond $C_{L_{max}}$ AOA is the stall region. Regardless of the flight conditions or airspeed, the wing will always stall at the same AOA, $C_{L_{max}}$ AOA. The only cause of a stall is excessive AOA. Stalls result in decreased lift, increased drag, and an altitude loss. They are particularly dangerous at low altitude or when allowed to develop into a spin. The only action necessary for stall recovery is to decrease AOA below $C_{L_{max}}$ AOA.

STALL INDICATIONS

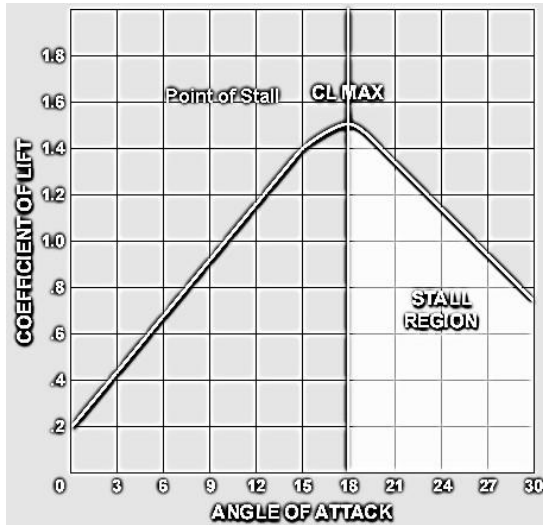

Figure 3-3 C_L vs. AOA

Numerous devices may give the pilot a warning of an impending stall. They include AOA indicators, rudder pedal shakers, stick shakers, horns, buzzers, warning lights and other devices. Some of these devices receive their input from attitude gyros, accelerometers, or flight data computers, but most receive input from an AOA probe. The AOA probe is mounted on the fuselage or wing and has a transmitter vane that remains aligned with the relative wind. The vane transmits the angle of attack of the relative wind to a cockpit AOA indicator or is used to activate other stall warning devices. Most U.S. military airplanes have standardized AOA indicators graduated in arbitrary units of angle of attack, or graduated from zero to 100 percent.

The T-6B AOA indicator is calibrated so that the airplane stalls at approximately 18 units angle of attack regardless of airspeed, nose attitude, weight or altitude. The AOA system in the T-6B is self-adjusting to account for differences in full-flap or no-flap stall angles. The T-6B also uses AOA indexer and stick shakers that receive their input from an AOA probe on the left wing. The stick shakers are activated at 15.5 units AOA, followed by airframe buffeting. Stalls at idle in a clean configuration are characterized by a nose down pitch with a slight rolling tendency to the right at near full aft stick. The effect of the landing gear and speed brake position on stalls is negligible, but extending the flaps will aggravate the stall characteristics by increasing the rolling tendency. Loss of control effectiveness progresses from ailerons to elevator to rudder in the T-6B.

STALL SPEED

As angle of attack increases, up to C_{Lmax} AOA, true airspeed decreases in level flight (Figure 3-3). Since C_L decreases beyond C_{Lmax} AOA, true airspeed cannot be decreased any further. Therefore, the minimum airspeed required for level flight occurs at C_{Lmax} AOA. Stall speed (V_S) is the minimum true airspeed required to maintain level flight at C_{Lmax} AOA. Although the stall speed may vary, the stalling AOA remains constant for a given airfoil. Since lift and weight are equal in equilibrium flight, weight (W) can be substituted for lift (L) in the lift equation. By solving for velocity (V), we derive a basic equation for stall speed.

$$V_S = \sqrt{\frac{2W}{\rho S C_{Lmax}}}$$

By substituting the stall speed equation into the true airspeed equation and solving for indicated airspeed, we derive the equation for the indicated stall speed (IAS_S). The greatest factors in stall speed

are weight, altitude, power, maneuvering, and configuration. Increased stall speed due to maneuvering (accelerated stall speed) will be discussed later.

$$IAS_S = \sqrt{\frac{2W}{\rho_0 S C_{L_{max}}}}$$

As airplane weight decreases, stall speed decreases because the amount of lift required to maintain level flight decreases. When an airplane burns fuel or drops ordnance, stall speeds decrease. Carrier pilots often dump fuel before shipboard landings in order to reduce stall speed and approach speed.

A comparison of two identical airplanes at different altitudes illustrates the effect of altitude on stall speed. The airplane at a higher altitude encounters fewer air molecules. In order to create sufficient dynamic pressure to produce the required lift, it must fly at a higher velocity (TAS). Therefore, an increase in altitude will increase stall speed. Since ρ_0 is constant, indicated stall speed will not change as altitude changes.

The stall speed discussed up to this point assumes that aircraft engines are at idle, and is called power-off stall speed. Power-on stall speed will be less than power-off stall speed because at high pitch attitudes, part of the weight of the airplane is actually being supported by the vertical component of the thrust vector (Figure 3-4). For propeller driven airplanes the portion of the wing immediately behind the propeller produces more lift because the air is being accelerated by the propeller (Figure 3-4).

$$V_S = \sqrt{\frac{2(W - T \sin \theta)}{\rho S C_{L_{max}}}}$$

$$IAS_S = \sqrt{\frac{2(W - T \sin \theta)}{\rho_0 S C_{L_{max}}}}$$

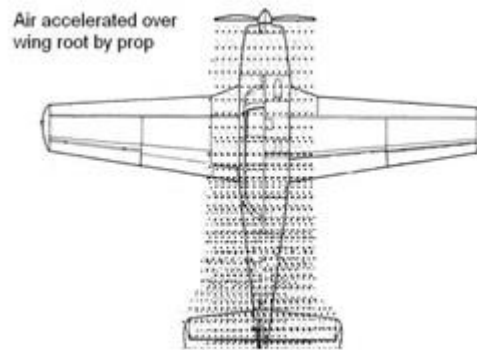
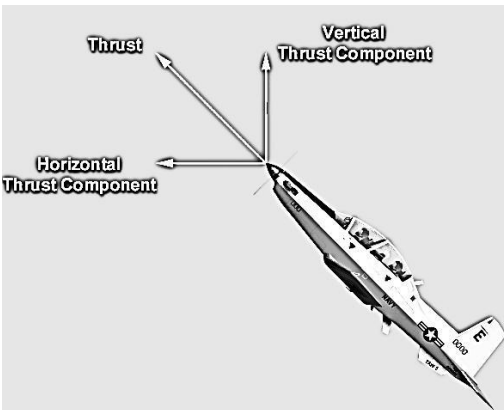

Figure 3-4 Power-On Stall

High Lift Devices

High lift devices also affect stall speeds since they increase C_L at high AOA. The primary purpose of high lift devices is to reduce takeoff and landing speeds by reducing both indicated and true stall speeds. The increase in C_L allows a decrease in airspeed. For example, an airplane weighing 20,000 pounds flying at 250 knots develops 20,000 pounds of lift. As the airplane slows to 125 knots for landing, high lift devices can increase C_L so that 20,000 pounds of lift can still be produced at the lower velocity. There are two common types of high lift devices: Those that delay boundary layer separation, and those that increase camber.

BOUNDARY LAYER CONTROL DEVICES

The maximum value of C_L is limited by the AOA at which boundary layer separation occurs. If airflow separation can be delayed to an AOA higher than normal stalling AOA, a higher C_{Lmax} can be achieved. Both C_{Lmax} and C_{Lmax} AOA increase with the use of Boundary Layer Control (BLC) devices (Figure 3-5).

Slots operate by allowing the high static pressure air beneath the wing to be accelerated through a nozzle and injected into the boundary layer on the upper surface of the airfoil (Figure 3-6). As the air is accelerated through the nozzle, its potential energy is converted to kinetic energy. Using this extra kinetic energy, the turbulent boundary layer is able to overcome the adverse pressure gradient and adhere to the airfoil at higher AOA. There are generally two types of slots, fixed slots and automatic slots.

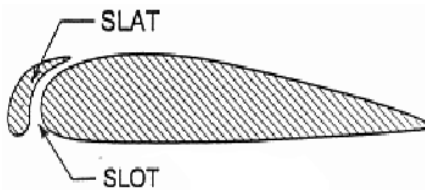

Figure 3-6 Slat and Slot

Fixed slots are gaps located at the leading edge of a wing that allow air to flow from below the wing to the upper surface. High pressure air from the vicinity of the leading edge stagnation point is directed through the slot, which acts as a nozzle converting the static pressure into dynamic pressure. The high kinetic energy air leaving the nozzle increases the energy of the boundary layer and delays separation. This is very efficient and causes only a small

increase in drag.

Slats are moveable leading edge sections used to form **automatic slots**. When the slat deploys, it opens a slot. Some slats are deployed aerodynamically. At low AOA, the slat is held flush against the leading edge by the high static pressure around the leading edge stagnation point. When the airfoil is at a high AOA, the leading edge stagnation point and associated high pressure area move down away from the leading edge and are replaced by a low (suction) pressure which creates a chordwise force forward and actuates the slat. Other automatic slots are deployed mechanically, hydraulically or electrically.

Since slats and slots on their own have no effect on camber, there is no change to C_L at low AOA. The higher value of C_{Lmax} is achieved at higher AOA, i.e. the stall is delayed to a higher AOA. (Figure 3-5). A simple form of BLC is achieved by vortex generators, which are small vanes installed on the upper surface of an airfoil to disturb the laminar boundary layer and induce a turbulent

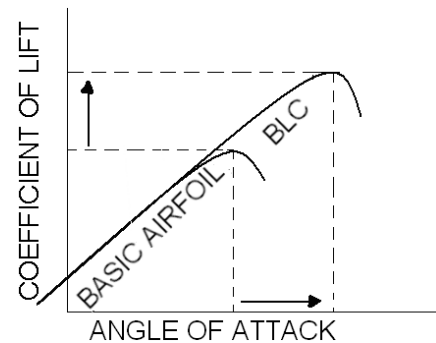

Figure 3-5 Effect of BLC

boundary layer. Because turbulent flow adheres to a surface more than laminar flow, vortex generators ensure the area behind them benefit from airflow that adheres better to the wing, delaying separation.

CAMBER CHANGE

The most common method of increasing $C_{L_{max}}$ is increasing the camber of the airfoil. There are various types of high lift devices that increase the camber of the wing and increase $C_{L_{max}}$. Trailing edge flaps are the most common type of high lift devices, but leading edge flaps are not unusual. The change in C_L and AOA due to flaps is shown in Figure 3-7. Note the value of C_L for this airfoil before and after flaps are deployed. Extending the flaps increases the airfoil's positive camber, shifting its zero lift point to the left. Note that the stalling AOA ($C_{L_{max}}$ AOA) decreases.

Although stalling AOA decreases, visibility on takeoff and landing improves due to flatter takeoff and landing attitudes made possible by these devices. Since boundary layer control devices increase stalling AOA, many modern designs utilize BLC with camber change devices to maintain low pitch attitudes during approach and landing. Flaps also increase the drag on the airplane, enabling a steeper glideslope and higher power setting during approach without increasing the airspeed. This allows an airplane such as an EA-6B to carry more thrust throughout the landing phase and not significantly increase the approach speed (a higher throttle setting results in less spool-up time in case of a wave-off or go-around). For many airplanes, the first 50 percent of flap down movement produces most of the desired lift increase with less than half of the unwanted drag increase. Thus, raising flaps from 100 to 50 percent reduces drag significantly without a large loss of lift. This is especially important during engine failures on multi-engine airplanes.

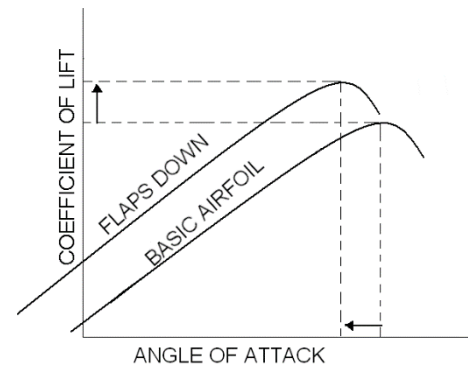

Figure 3-7 Effect of Flaps

TRAILING EDGE FLAPS

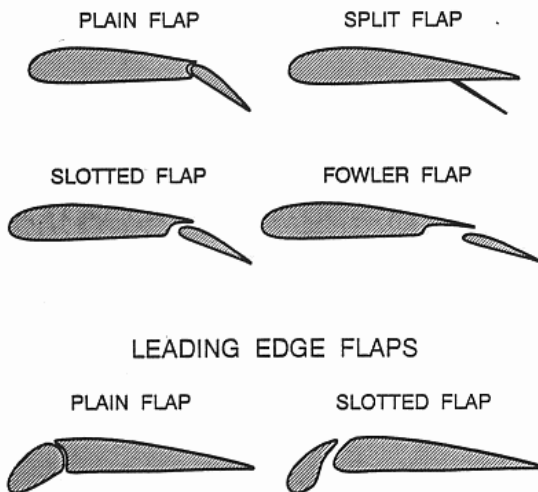

Figure 3-8 Types of Flaps

A **plain flap** is a simple hinged portion of the trailing edge that is forced down into the airstream to increase the camber of the airfoil. A **split flap** is a plate deflected from the lower surface of the airfoil. This type of flap creates a lot of drag because of the turbulent air between the wing and deflected surface. A **slotted flap** is similar to the plain flap, but moves away from the wing to open a narrow slot between the flap and wing for boundary layer control. A slotted flap may cause a slight increase in wing area, but the increase in lift is insignificant. The **fowler flap** is used extensively on larger airplanes. When extended, it moves down, increasing the camber, and aft, causing a significant increase in wing area as well as opening one or more slots for boundary layer control. Because of the larger area created on airfoils with fowler flaps, a large twisting moment is developed. This requires a structurally stronger wing to withstand the

increased twisting load and precludes their use on high speed, thin wings.

Leading edge flaps are devices that change the wing camber at the leading edge of the airfoil. They may be operated manually with a switch or automatically by computer. Leading edge plain flaps are similar to a trailing edge plain flap. Leading edge slotted flaps are similar to trailing edge slotted flaps, but are sometimes confused with automatic slots. Often the terms are interchangeable since many leading edge devices have some characteristics of both flaps and slats.

The exact stall speed for various airplane conditions are given in stall speed charts in an airplane's flight manual. The directions on how to use the stall speed chart are on the chart itself and are self-explanatory.

Stall Pattern And Wing Design

The most desirable stall pattern on a wing is one that begins at the root. The primary reason for a root first stall pattern is to maintain aileron effectiveness until the wing is fully stalled. Additionally, turbulent airflow from the wing root may buffet the empennage, providing an aerodynamic warning of impending stall. Different planforms have characteristic stall patterns (Figure 3-9).

The lift distribution on the **rectangular wing** ($\lambda = 1.0$) is due to low lift coefficients at the tip and high lift coefficients at the root. Since the area of the highest lift coefficient will stall first, the rectangular wing has a strong root stall tendency. This pattern provides adequate stall warning and aileron effectiveness. This planform is limited to low speed, light-weight airplanes where simplicity of construction and favorable stall characteristics are the predominating requirements.

A **highly tapered wing** ($\lambda = 0.25$) is desirable from the standpoint of structural weight, stiffness, and wingtip vortices. Tapered wings produce most of the lift toward the tip and have a strong tip stall tendency.

Swept wings are used on high speed aircraft because they reduce drag and allow the airplane to fly at higher Mach numbers. They have a similar lift distribution to a tapered wing, and therefore stall easily and have a strong tip stall tendency. When the wingtip stalls, the stall rapidly progresses over the remainder of the wing.

The **elliptical wing** has an even distribution of lift from the root to the tip and produces minimum induced drag. An even lift distribution means that all sections stall at the same angle of attack. There is little advanced warning and aileron effectiveness may be lost near a stall. It is also more difficult to manufacture than other planforms, but is considered the ideal subsonic wing due to its lift to drag ratio.

Moderate taper wings ($\lambda = 0.5$) have a lift distribution and stall pattern that is similar to the elliptical wing. The T-6B uses tapered wings because they reduce weight, improve stiffness, and reduce wingtip vortices. However, the even stall progression is undesirable for the same reasons as with the elliptical wing. As a stall progresses, the pilot will lose lateral control of the airplane.

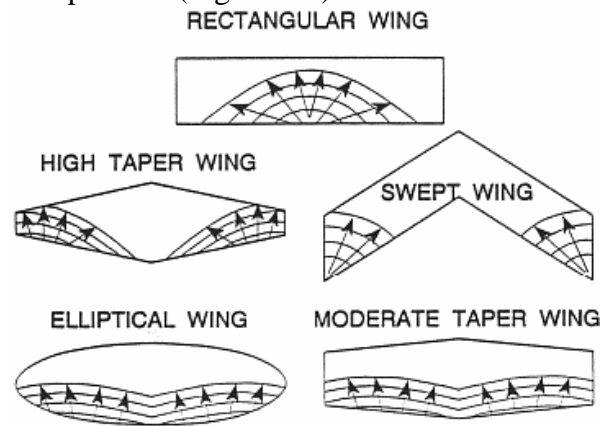

Figure 3-9 Stall Patterns

Wing Tailoring

Although stalls cannot be eliminated, they can be made more predictable by having the wing stall gradually. Since most airplanes do not have rectangular wings, they tend to stall with little or no warning. Wing tailoring techniques are used to create a root-to-tip stall progression and give the pilot some stall warning while ensuring that the ailerons remain effective up to a complete stall. Trailing edge flaps decrease the stalling angles of attack in their vicinity, causing initial stall in the flap area. BLC devices generally delay stall in their vicinity. Propeller-driven airplanes may have a tip stall tendency during power-on stalls due to the increased airflow over the wing root.

Geometric twist is a decrease in angle of incidence from wing root to wingtip (Figure 3-10). The root section is mounted at some angle to the longitudinal axis, and the leading edge of the remainder of the wing is gradually twisted downward. This results in a decreased AOA at the wingtip due to its lower angle of incidence. The root stalls first because of its higher AOA. The T-6B wing is geometrically twisted.

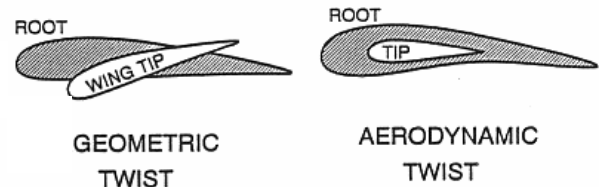

Figure 3-10 Wing Tailoring

Aerodynamic twist, also called section variation, is a gradual change in airfoil shape that increases C_{Lmax} AOA to a higher value near the tip than at the root (Figure 3-10). This can be accomplished by a decrease in camber from the root to the tip and/or by a decrease in the relative thickness of the wing (as compared to chord) from the root to the tip. Since thicker and more positively cambered airfoils stall at lower angles of attack, the wing root stalls before the wingtip. The T-6B wings are aerodynamically twisted.

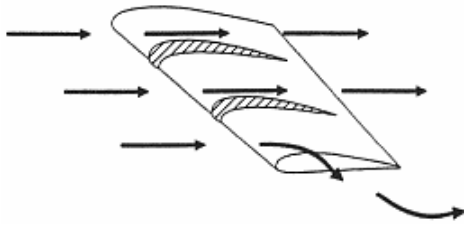

Figure 3-11 Stall Fences

The spanwise flow on a swept wing is not accelerated over the wing and does not contribute to the production of lift. Instead, it induces a strong tip stall tendency. **Stall fences** redirect the airflow along the chord, thereby delaying tip stall and enabling the wing to achieve a higher AOA without stalling (Figure 3-11).

The T-6B uses a sharply angled piece of metal called a **stall strip** mounted on the leading edge of the root section to induce a stall at the wing root (Figure 3-12). Since subsonic airflow cannot flow easily around sharp corners, it separates the boundary layer at higher angles of attack, ensuring that the root section stalls first.

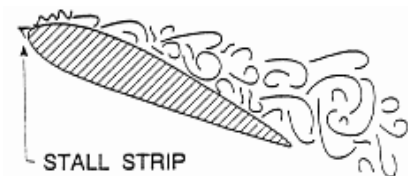

Figure 3-12 Stall Strip

STALL RECOVERY

To produce the required lift at slow airspeeds, the pilot must fly at high angles of attack. Because flying slow at high angles of attack is one of the most critical phases of flight, pilots practice recovering from several types of stalls during training.

The steps in a stall recovery involve simultaneously adding power, relaxing back stick pressure and rolling wings level and using rudder to ensure coordinated flight (“RELAX, MAX, LEVEL, BALL”).

1. Reduce angle of attack. This may require a reduction in back stick pressure, moving stick progressively towards neutral, or moving stick forward of the trim position.
2. Advance PCL as required to maintain flying airspeed. Anticipate engine power effects, applying aileron and rudder as necessary to maintain or achieve wings level.
3. Use aileron and rudder control as necessary to maintain wings-level, coordinated flight throughout the recovery.
4. As flying speed is regained, smoothly increase back pressure on the control stick to stop the altitude loss and return to level flight, taking care to avoid entering a secondary, accelerated stall during recovery.

ASSIGNMENT SHEET 2-3-3

STALLS REVIEW

A. INTRODUCTION

This lesson covers fundamental information on the aerodynamic causes and characteristics of aircraft stalls. Factors affecting stalls, anti-stall devices, and T-6 stalls are also discussed.

B. ENABLING OBJECTIVES

C. STUDY ASSIGNMENT

1. Review Naval Aviation Fundamentals, NAVAVSCOLSCOM-SG-200 Unit 2, Chapter 4
2. Read Naval Aviation Fundamentals, NAVAVSCOLSCOM-SG-200 Unit 2, Chapter 5

D. STUDY QUESTIONS

1. What is the definition of boundary layer separation?
2. What effect does increasing AOA have on the kinetic energy of the relative wind?
3. What is the definition of a stall?
4. What are the two major classifications of stalls?
5. What are the factors associated with increased thrust that impact stall characteristics?
6. Which aircraft would stall at a higher indicated airspeed?



7. What are the benefits provided by Boundary Layer Control (BLC) devices?
8. Which type of stall will have the lower stall airspeed?
9. What is the T-6B stall AOA?
10. What is the only reason the T-6B will stall?

Answers:

1. Point in streamline where airflow no longer adheres to the airfoil
2. Decreases it
3. Condition in flight where increase in AOA results in decrease in C_L
4. Power-on stall and power-off stall
5. Vertical component of thrust and propeller acceleration factor
6. 6000 pound aircraft
7. Increased maneuvering capabilities, decreased landing speed and distance
8. Power-on stall
9. 18 units
10. Exceeding T-6B stall AOA (18 units)

OUTLINE SHEET 2-4-1

PERFORMANCE & MANEUVERING

A. INTRODUCTION

Performance and Maneuvering is the third aerodynamics lesson in a series presenting aerodynamic theories and operational principles. Upon completion of this lesson, you will understand aircraft performance with respect to temperature, maximum range and endurance, and aircraft speeds relating to the lift and thrust curves. You will also understand maneuvering characteristics relating to velocity, angle of attack, load factor, and aircraft stability.

B. ENABLING OBJECTIVES

- 2.124 **DEFINE** takeoff and landing airspeed in terms of stall speed, in a classroom, in accordance with Naval Aviation Fundamentals, NAVAVSCOLSCOM-SG-200
- 2.125 **STATE** the various forces acting on an airplane during the takeoff and landing transition, in a classroom, in accordance with Naval Aviation Fundamentals, NAVAVSCOLSCOM-SG-200
- 2.126 **STATE** the factors that determine the coefficient of rolling friction, in a classroom, in accordance with Naval Aviation Fundamentals, NAVAVSCOLSCOM-SG-200
- 2.127 **DESCRIBE** the effects on takeoff and landing performance, given variations in weight, altitude, temperature, humidity, wind, and braking, in a classroom, in accordance with Naval Aviation Fundamentals, NAVAVSCOLSCOM-SG-200
- 2.128 **DESCRIBE** the effects of outside air temperature (OAT) on airplane performance characteristics, in a classroom, in accordance with Naval Aviation Fundamentals, NAVAVSCOLSCOM-SG-200
- 2.129 **DEFINE** maximum angle of climb and maximum rate of climb profiles, in a classroom, in accordance with Naval Aviation Fundamentals, NAVAVSCOLSCOM-SG-200
- 2.130 **EXPLAIN** the performance characteristics profiles that yield maximum angle of climb and maximum rate of climb for turboprops, in a classroom, in accordance with Naval Aviation Fundamentals, NAVAVSCOLSCOM-SG-200
- 2.131 **DESCRIBE** the effect of changes in weight, altitude, configuration, and wind on maximum angle of climb and maximum rate of climb profiles, in a classroom, in accordance with Naval Aviation Fundamentals, NAVAVSCOLSCOM-SG-200

- 2.132 DESCRIBE the performance characteristics and purpose of the best climb profile for the T-6B, in a classroom, in accordance with Naval Aviation Fundamentals, NAVAVSCOLSCOM-SG-200
- 2.133 DEFINE absolute ceiling, service ceiling, cruise ceiling, combat ceiling, and maximum operating ceiling, in a classroom, in accordance with Naval Aviation Fundamentals, NAVAVSCOLSCOM-SG-200
- 2.134 STATE the maximum operating ceiling of the T-6B, in a classroom, in accordance with Naval Aviation Fundamentals, NAVAVSCOLSCOM-SG-200
- 2.135 STATE the relationship between fuel flow, power available, power required, and velocity for a turboprop airplane in straight and level flight, in a classroom, in accordance with Naval Aviation Fundamentals, NAVAVSCOLSCOM-SG-200
- 2.136 DEFINE maximum range and maximum endurance profiles, in a classroom, in accordance with Naval Aviation Fundamentals, NAVAVSCOLSCOM-SG-200
- 2.137 EXPLAIN the performance characteristics profiles that yield maximum endurance and maximum range for turboprops, in a classroom, in accordance with Naval Aviation Fundamentals, NAVAVSCOLSCOM-SG-200
- 2.138 DESCRIBE the effect of changes in weight, altitude, configuration, and wind on maximum endurance and maximum range performance and airspeed, in a classroom, in accordance with Naval Aviation Fundamentals, NAVAVSCOLSCOM-SG-200
- 2.139 DEFINE Mach number, in a classroom, in accordance with Naval Aviation Fundamentals, NAVAVSCOLSCOM-SG-200
- 2.140 DEFINE critical Mach, in a classroom, in accordance with Naval Aviation Fundamentals, NAVAVSCOLSCOM-SG-200
- 2.141 STATE the effects of altitude on Mach number and critical Mach number, in a classroom, in accordance with Naval Aviation Fundamentals, NAVAVSCOLSCOM-SG-200
- 2.142 DEFINE maximum glide range and maximum glide endurance profiles, in a classroom, in accordance with Naval Aviation Fundamentals, NAVAVSCOLSCOM-SG-200
- 2.143 EXPLAIN the performance characteristics profiles that yield maximum glide range and maximum glide endurance, in a classroom, in accordance with Naval Aviation Fundamentals, NAVAVSCOLSCOM-SG-200
- 2.144 DESCRIBE the effect of changes in weight, altitude, configuration, wind, and propeller feathering on maximum glide range and maximum glide endurance performance and

airspeed, in a classroom, in accordance with Naval Aviation Fundamentals, NAVAVSCOLSCOM-SG-200

- 2.145 DESCRIBE the locations of the regions of normal and reverse command on the turboprop power curve, in a classroom, in accordance with Naval Aviation Fundamentals, NAVAVSCOLSCOM-SG-200
- 2.146 EXPLAIN the relationship between power required and airspeed in the regions of normal and reverse command, in a classroom, in accordance with Naval Aviation Fundamentals, NAVAVSCOLSCOM-SG-200
- 2.147 DEFINE nosewheel liftoff/touchdown speed, in a classroom, in accordance with Naval Aviation Fundamentals, NAVAVSCOLSCOM-SG-200
- 2.148 STATE the pilot speed and attitude inputs necessary to control the airplane during a crosswind landing, in a classroom, in accordance with Naval Aviation Fundamentals, NAVAVSCOLSCOM-SG-200
- 2.149 STATE the crosswind limits for the T-6B, in a classroom, in accordance with Naval Aviation Fundamentals, NAVAVSCOLSCOM-SG-200
- 2.150 DEFINE hydroplaning, in a classroom, in accordance with Naval Aviation Fundamentals, NAVAVSCOLSCOM-SG-200
- 2.151 STATE the factors that affect the speed at which an airplane will hydroplane, in a classroom, in accordance with Naval Aviation Fundamentals, NAVAVSCOLSCOM-SG-200
- 2.152 DESCRIBE the effects of propeller slipstream swirl, P-factor, torque, and gyroscopic precession as they apply to the T-6B, in a classroom, in accordance with Naval Aviation Fundamentals, NAVAVSCOLSCOM-SG-200
- 2.153 DESCRIBE what the pilot must do to compensate for propeller slipstream swirl, P-factor, torque, and gyroscopic precession as they apply to the T-6B, in a classroom, in accordance with Naval Aviation Fundamentals, NAVAVSCOLSCOM-SG-200
- 2.154 DESCRIBE the effect of lift on turn performance, in a classroom, in accordance with Naval Aviation Fundamentals, NAVAVSCOLSCOM-SG-200
- 2.155 DESCRIBE the effect of weight on turn performance, in a classroom, in accordance with Naval Aviation Fundamentals, NAVAVSCOLSCOM-SG-200
- 2.156 DESCRIBE the effect of thrust on turn performance, in a classroom, in accordance with Naval Aviation Fundamentals, NAVAVSCOLSCOM-SG-200

- 2.157 DESCRIBE the effect of drag on turn performance, in a classroom, in accordance with Naval Aviation Fundamentals, NAVAVSCOLSCOM-SG-200
- 2.158 DEFINE turn radius and turn rate, in a classroom, in accordance with Naval Aviation Fundamentals, NAVAVSCOLSCOM-SG-200
- 2.159 DESCRIBE the effects of changes in bank angle on turn performance, in a classroom, in accordance with Naval Aviation Fundamentals, NAVAVSCOLSCOM-SG-200
- 2.160 DESCRIBE the effects of changes in airspeed on turn performance, in a classroom, in accordance with Naval Aviation Fundamentals, NAVAVSCOLSCOM-SG-200
- 2.161 DESCRIBE the effects of aileron and rudder forces during turns, in a classroom, in accordance with Naval Aviation Fundamentals, NAVAVSCOLSCOM-SG-200
- 2.162 EXPLAIN the aerodynamic principle that requires two G's of back stick pressure to maintain level, constant airspeed flight, at 60 degrees angle of bank, in a classroom, in accordance with Naval Aviation Fundamentals, NAVAVSCOLSCOM-SG-200
- 2.163 DESCRIBE the relationship between load factor and angle of bank for level, constant-air-speed-flight, in a classroom, in accordance with Naval Aviation Fundamentals, NAVAVSCOLSCOM-SG-200
- 2.164 DEFINE load, load factor, limit load factor, and ultimate load factor, in a classroom, in accordance with Naval Aviation Fundamentals, NAVAVSCOLSCOM-SG-200
- 2.165 DEFINE static strength, static failure, fatigue strength, fatigue failure, service life, creep, and overstress/over-G, in a classroom, in accordance with Naval Aviation Fundamentals, NAVAVSCOLSCOM-SG-200
- 2.166 DEFINE maneuvering speed, cornering velocity, redline airspeed, accelerated stall lines, and the safe flight envelope, in a classroom, in accordance with Naval Aviation Fundamentals, NAVAVSCOLSCOM-SG-200
- 2.167 DESCRIBE the boundaries of the safe flight envelope, including accelerated stall lines, limit load factor, ultimate load factor, maneuver point, and redline airspeed, in a classroom, in accordance with Naval Aviation Fundamentals, NAVAVSCOLSCOM-SG-200
- 2.168 DEFINE asymmetric loading and state the associated limitations for the T-6B, in a classroom, in accordance with Naval Aviation Fundamentals, NAVAVSCOLSCOM-SG-200

- 2.169 DEFINE static stability and dynamic stability, in a classroom, in accordance with Naval Aviation Fundamentals, NAVAVSCOLSCOM-SG-200
- 2.170 DESCRIBE the characteristics exhibited by aircraft with positive, neutral, and negative static stabilities, when disturbed from equilibrium, in accordance with Naval Aviation Fundamentals, NAVAVSCOLSCOM-SG-200
- 2.171 DESCRIBE the characteristics exhibited by aircraft with positive, neutral, and negative dynamic stabilities, when disturbed from equilibrium, in accordance with Naval Aviation Fundamentals, NAVAVSCOLSCOM-SG-200
- 2.172 DESCRIBE the characteristics of damped, undamped, and divergent oscillations, and the combination of static and dynamic stabilities that result in each, in a classroom, in accordance with Naval Aviation Fundamentals, NAVAVSCOLSCOM-SG-200
- 2.173 EXPLAIN the relationship between stability and maneuverability, in a classroom, in accordance with Naval Aviation Fundamentals, NAVAVSCOLSCOM-SG-200
- 2.174 STATE the methods for increasing an airplane's maneuverability, in a classroom, in accordance with Naval Aviation Fundamentals, NAVAVSCOLSCOM-SG-200
- 2.175 STATE the effects of airplane components on an airplane's longitudinal static stability, in a classroom, in accordance with Naval Aviation Fundamentals, NAVAVSCOLSCOM-SG-200
- 2.176 EXPLAIN the criticality of weight and balance, in a classroom, in accordance with Naval Aviation Fundamentals, NAVAVSCOLSCOM-SG-200
- 2.177 STATE the effects of airplane components on an airplane's directional static stability, in a classroom, in accordance with Naval Aviation Fundamentals, NAVAVSCOLSCOM-SG-200
- 2.178 STATE the effects of airplane components on an airplane's lateral static stability, in a classroom, in accordance with Naval Aviation Fundamentals, NAVAVSCOLSCOM-SG-200
- 2.179 STATE the static stability requirements for, and the effects of, directional divergence, in a classroom, in accordance with Naval Aviation Fundamentals, NAVAVSCOLSCOM-SG-200
- 2.180 STATE the static stability requirements for, and the effects of, spiral divergence, in a classroom, in accordance with Naval Aviation Fundamentals, NAVAVSCOLSCOM-SG-200

- 2.181 STATE the static stability requirements for, and the effects of, Dutch roll, in a classroom, in accordance with Naval Aviation Fundamentals, NAVAVSCOLSCOM-SG-200
- 2.182 DEFINE proverse roll, in a classroom, in accordance with Naval Aviation Fundamentals, NAVAVSCOLSCOM-SG-200
- 2.183 DEFINE adverse yaw, in a classroom, in accordance with Naval Aviation Fundamentals, NAVAVSCOLSCOM-SG-200
- 2.184 EXPLAIN how an airplane develops phugoid oscillations, in a classroom, in accordance with Naval Aviation Fundamentals, NAVAVSCOLSCOM-SG-200
- 2.185 EXPLAIN how an airplane develops pilot induced oscillations, in a classroom, in accordance with Naval Aviation Fundamentals, NAVAVSCOLSCOM-SG-200
- 2.186 DEFINE asymmetric thrust, in a classroom, in accordance with Naval Aviation Fundamentals, NAVAVSCOLSCOM-SG-200

C. TOPIC OUTLINE

1. Introduction
2. This Lesson Topic
3. Takeoff Performance
4. Climb Performance
5. Cruise Performance
6. Glide Performance
7. Reverse Command
8. Landing Performance
9. Propeller
10. Turn Performance
11. Slips and Skids
12. Load Factor
13. V-n Diagram
14. Factors Affecting the Safe Flight Envelope
15. Static vs Dynamic Stability
16. Contributors to Longitudinal, Directional, and Lateral Stability
17. Dynamic Factors Affecting Stability
18. Summary and Review
19. Application
20. Assignment

INFORMATION SHEET 2-4-2

PERFORMANCE AND MANEUVERING

A. INTRODUCTION

Performance and Maneuvering is the fourth aerodynamics lesson in a series presenting aerodynamic theories and operational principles. Upon completion of this lesson, you will understand aircraft performance with respect to temperature, maximum range and endurance, and aircraft speeds relating to the lift and thrust curves. You will also understand maneuvering characteristics relating to velocity, angle of attack, load factor, and aircraft stability.

B. REFERENCES

1. Aerodynamics for Naval Aviators, NAVAIR 00-80T-80
2. Introduction to the Aerodynamics of Flight, NASA SP-367
3. T-6 Joint Primary Pilot Training, AETC / CNATRA Syllabus P-V4A-J NATOPS Flight Manual

C. INFORMATION

Takeoff Speed

Takeoffs are a transitional maneuver during which the weight of the airplane is shifted from the landing gear to the wings. The minimum airspeed for takeoff is 20 percent above the power off stall speed. Thus, it is affected by the same factors that affect stall speed. This 20 percent safety margin minimizes operation in the region of reverse command and allows for shallow turns after takeoff, especially during an engine failure. High lift devices are often used to decrease takeoff speeds. Note that the below equation is expressed in terms of true airspeed:

$$V_{TO} \approx 1.2 \sqrt{\frac{2W}{\rho S C_{L \max}}}$$

Indicated airspeed for takeoff will not be affected by changes in air density:

$$IAS_{TO} \approx 1.2 \sqrt{\frac{2W}{\rho_0 S C_{L \max}}}$$

TAKEOFF FORCES

Figure 4-1 shows the forces acting on an airplane during takeoff. During ground roll, **rolling friction** (F_R) accounts for the effects of friction between the landing gear and the runway. Like any frictional force, it is the product of a coefficient of friction (μ) and a perpendicular force (weight-on-wheels or WOW). WOW is the difference between weight and lift. The coefficient of friction (μ) is dependent upon runway surface, runway condition, tire type and degree of brake application. Note that brake application should be negligible during takeoff.

$$F_R = \mu(W - L)$$

Takeoff performance is dependent upon acceleration. According to Newton's Second Law, a body accelerates in the direction of the unbalanced force acting on it. Thrust is the most out of balance force on takeoff. For an airplane to accelerate from zero to its takeoff speed, it must generate enough thrust to overcome rolling friction (F_R) and drag (D).

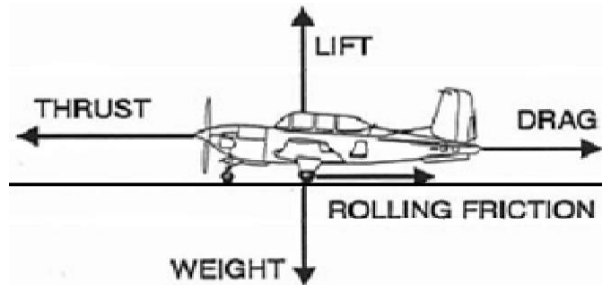

Figure 4-1 Takeoff and Landing Forces

$T - D - F_R$ is called the **net accelerating force**.

Although thrust and weight may change slightly during our takeoff, we will consider them to remain nearly constant.

As velocity increases during takeoff, the aerodynamic force increases, increasing both lift and drag (drag is primarily parasitic during a takeoff or landing). The increase in lift during the takeoff roll decreases the weight on wheels and rolling friction.

TAKEOFF PERFORMANCE

An equation for determining minimum takeoff distance is:

$$S_{TO} = \frac{W^2}{g\rho S C_{L_{max}} (T - D - F_R)}$$

where g = gravity.

Weight is the greatest factor in determining takeoff distance. Looking at the takeoff distance formula, we see that doubling the weight will increase the takeoff distance by a factor of four. Increasing weight requires greater lift and a higher takeoff velocity. It also increases rolling friction which decreases the net accelerating force.

Most takeoff and landing performance charts use density altitude (DA) to account for air density. Increasing DA (decreasing air density) requires a higher takeoff velocity and decreases the amount of thrust our engine can provide. This will decrease the acceleration on the takeoff roll and increase the minimum takeoff distance. There are three major factors that decrease density: increasing airfield

elevation, increasing air temperature and increasing humidity. Note that indicated takeoff airspeed remains constant, regardless of temperature, humidity, and elevation.

Along with weight, these three density factors are the worst conditions for takeoff and landing. A helpful mnemonic device is the “**4-H Club**,” where the members of the club are high, hot, heavy and humid. Whenever three or more of the 4-H Club are present, expect extended takeoff and landing distances. Under extreme circumstances, two or even one of the factors may cause longer takeoff and landing distances.

Using high lift devices such as flaps or boundary layer control devices will decrease the takeoff distance. High lift devices decrease both the indicated and true takeoff speeds. Since true airspeed for takeoff decreases, the ground speed during takeoff will decrease, thus decreasing takeoff distance.

A headwind will decrease the takeoff distance by reducing the ground speed associated with the takeoff velocity. Conversely, a tail wind will increase takeoff distance since it increases ground speed.

CLIMB PERFORMANCE

A “steady climb” is defined as a climb in which the airplane is not accelerating; the airplane is in equilibrium. However, the altitude is no longer constant. In this discussion, the same thrust and power curves are used to analyze level flight to discuss and locate the different climb performance parameters of an airplane. Both types of climbs discussed are performed at maximum power.

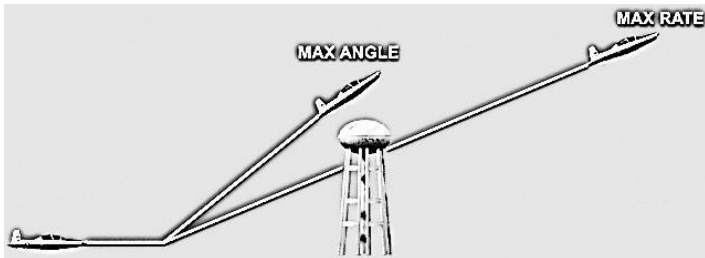

Figure 4-2 Max AOC vs. Max ROC

Angle of climb (γ , AOC) is a comparison of altitude gained to distance traveled. For maximum angle of climb, we want maximum vertical velocity (altitude increase) for a minimum horizontal velocity (ground speed). Maximum AOC is commonly used when taking off from a short airfield surrounded by high obstacles, such as trees, or power lines. The objective is to

gain sufficient altitude to clear the obstacle with the least horizontal distance traveled. Rate of climb (ROC) is a comparison of altitude gained relative to the time needed to reach that altitude. Flying at maximum rate of climb yields a maximum vertical velocity. Maximum rate of climb is used to expedite a climb to an assigned altitude. The greatest vertical distance must be gained in the shortest time possible.

In a maximum angle of climb profile, a certain airplane takes 30 seconds to reach 1000 feet AGL, but covers only 3000 feet over the ground. Using its maximum rate of climb profile, the same airplane climbs to 1500 feet in 30 seconds, but covers 6000 feet across the ground. It should be noted that both climb profiles are executed at maximum throttle setting, and that differences between max rate and max angle of climb lie solely in differences of angle of attack and velocity.

ANGLE OF CLIMB

The equations that represent equilibrium in a climb are (Figure 4-3):

$$L = W \cos \gamma$$

$$T = D + W \sin \gamma$$

By rearranging the bottom equation, we see that:

$$\sin \gamma = \frac{T - D}{W} = \frac{T_A - T_R}{W} = \frac{T_E}{W}$$

Thus, angle of climb performance depends upon thrust excess. Essentially, the greater the force that pushes the airplane upwards, the steeper it can climb. Maximum angle of climb occurs at the velocity and angle of attack that produce the maximum thrust excess. Therefore, maximum angle of climb for a turbojet occurs at L/D_{MAX} AOA and velocity. Maximum angle of climb for a turboprop occurs at a velocity less than L/D_{MAX} and an angle of attack greater than L/D_{MAX} AOA.

At max angle of climb, an aircraft can be operating near stall speed. Therefore, for the T-6B, the recommended best climb speed is 140 KIAS. This speed will meet or exceed any obstacle clearance requirements while providing a greater safety margin. Max angle of climb is not flown in the T-6B.

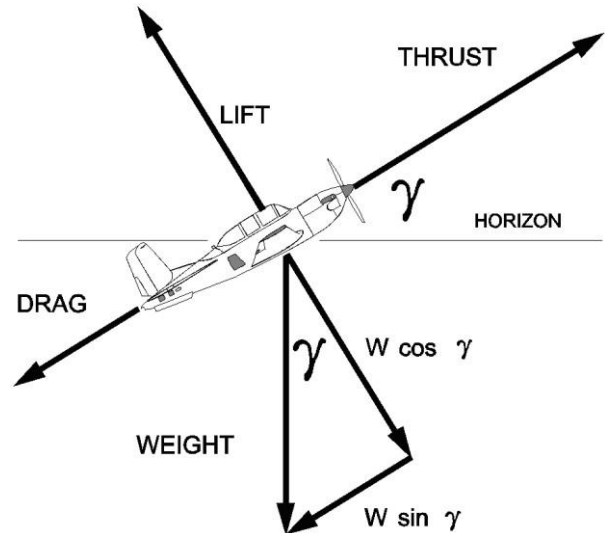

Figure 4-3 Climb Forces

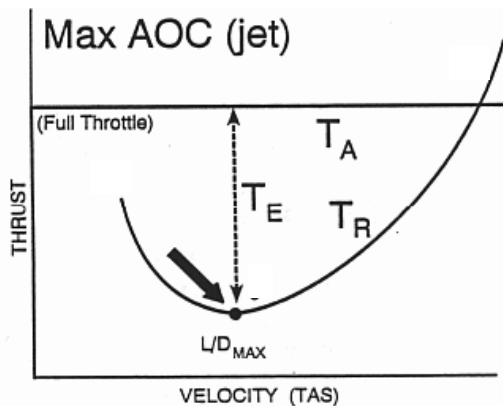

Figure 4-4 Turbojet Angle of Climb

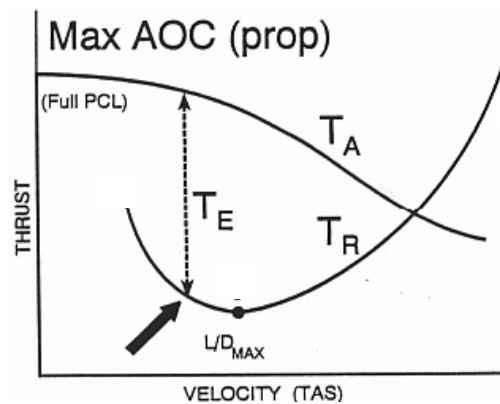

Figure 4-5 Turboprop Angle of Climb

RATE OF CLIMB

Rate of climb (ROC) is simply the vertical component of velocity (Figure 4-6):

$$ROC = V \sin \gamma$$

$$\sin \gamma = \frac{T_A - T_R}{W} = \frac{T_E}{W}$$

By substitution:

$$ROC = V \sin \gamma = \frac{VT_E}{W} = \frac{P_E}{W}$$

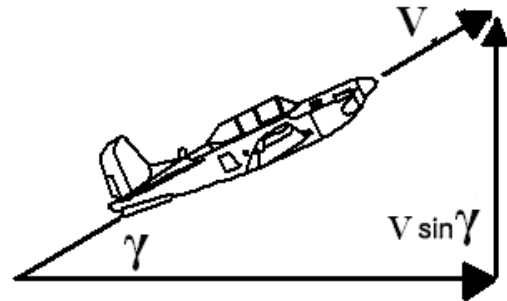

Figure 4-6 Climb Velocity Vectors

Thus, rate of climb performance depends upon power excess. Since climbing is work and power is the rate of doing work, any power that is not used to maintain level flight can increase the rate of climbing. Maximum rate of climb occurs at the velocity and angle of attack that produce the maximum power excess. Therefore, maximum rate of climb for a turbojet occurs at a velocity greater than L/D_{MAX} and an angle of attack less than L/D_{MAX} AOA. Maximum rate of climb for a turboprop occurs at L/D_{MAX} AOA and velocity. Best climb speed, not max rate of climb, is flown in the T-6B.

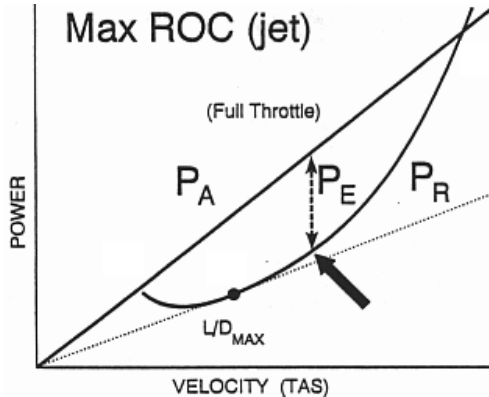

Figure 4-7 Turbojet Rate of Climb

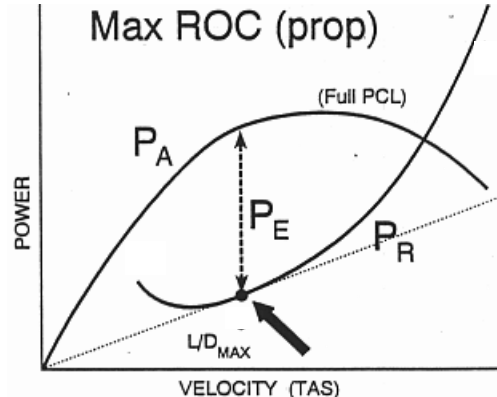

Figure 4-8 Turboprop Rate of Climb

Climb Performance Factors

Since weight, altitude, and configuration changes affect thrust and power excess, they will also affect climb performance. Climb performance is directly dependent upon the ability to produce either a thrust excess or a power excess. In the previous lesson, it was determined that an increase in weight, an increase in altitude, lowering the landing gear, or lowering the flaps will all decrease both maximum thrust excess and maximum power excess in all airplanes. Therefore, maximum angle of climb and maximum rate of climb performance will decrease under any of these conditions.

Consider an airplane that has a maximum angle of climb TAS of 160 knots, a ground speed of 160 knots, and no wind. If this airplane flies into a headwind of 30 knots, its ground speed is reduced to 130 knots. The headwind has increased the airplane's maximum angle of climb, because it reaches the same altitude as before with a smaller distance covered over the ground. A tailwind has the opposite effect (Figure 4-9). Wind does not affect rate of climb performance.

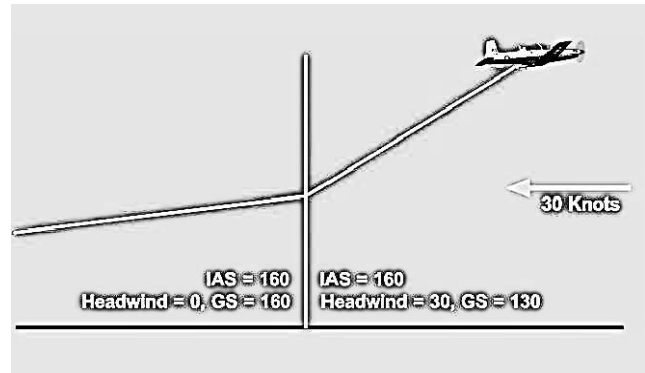

Figure 4-9 Effect of Wind on Max AOC

LEVEL FLIGHT PERFORMANCE

Fuel flow is the rate of fuel consumption by the engine, measured in pounds per hour (pph). Since the supply of fuel onboard is limited, the engine's fuel flow is a critical determinant of how long and how far the airplane can fly. A turbojet engine directly produces thrust through its exhaust. Therefore, the fuel consumed by a turbojet engine is proportional to its thrust available (T_A). In order to maintain equilibrium flight, thrust available must be set equal to thrust required (T_R), therefore we say that minimum fuel flow for a turbojet is found on the thrust required curve.

The thrust provided by a propeller is not produced directly by the engine, so there is no direct relationship between thrust and fuel flow. The engine turns a shaft that turns the propeller that produces the thrust. In turning the shaft, the engine produces power. Therefore, for a turboprop, fuel flow varies directly with the power output of the engine (P_A). Minimum fuel flow for equilibrium flight will be found on the power required (P_R) curve.

Maximum endurance and maximum range are both achieved in equilibrium, level flight. Any thrust or power excess would cause the airplane to either climb or accelerate. We will look on the thrust required or power required curve to determine the velocity that our airplane must fly. Once the velocity is determined, the pilot must adjust the throttle to eliminate any thrust or power excess.

Maximum endurance is the maximum amount of time that an airplane can remain airborne on a given amount of fuel. The slower an engine burns fuel, the longer the airplane can remain airborne. Minimum fuel flow occurs at minimum T_R for a turbojet and minimum P_R for a turboprop. Therefore, maximum endurance is found at L/D_{MAX} AOA and velocity for a turbojet and at a velocity less than L/D_{MAX} , and an angle of attack greater than L/D_{MAX} AOA for a turboprop. For the T-6B, maximum endurance is achieved at 8.8 units AOA.

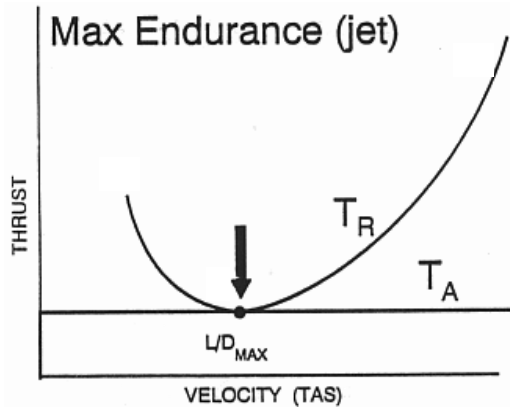

Figure 4-10 Turbojet Maximum Endurance

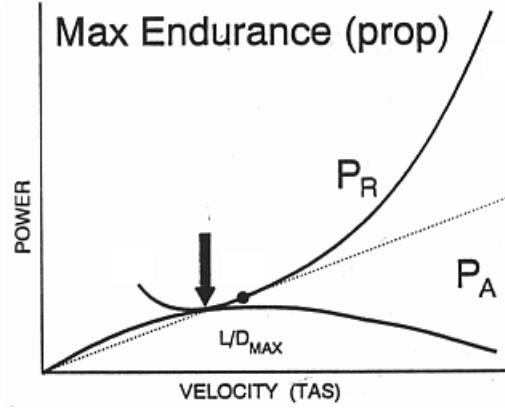

Figure 4-11 Turboprop Maximum Endurance

Maximum range is the maximum distance traveled over the ground for a given amount of fuel. To find maximum range we must minimize fuel flow per unit of velocity. Any straight line drawn from the origin represents a constant ratio of fuel flow to velocity. The minimum ratio that allows the airplane to remain airborne occurs where the line from the origin is tangent to the T_R curve for jets or the P_R curve for props. Maximum range for a turbojet is found at a velocity greater than L/D_{MAX} and an angle of attack less than L/D_{MAX} AOA. Maximum range for a turboprop is found at L/D_{MAX} AOA and velocity. Maximum range with no wind is achieved in the T-6B is at 4.4 units AOA. Note that maximum range is faster than maximum endurance.

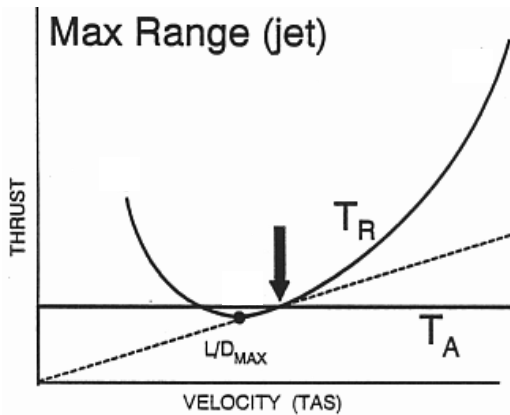

Figure 4-12 Turbojet Maximum Range

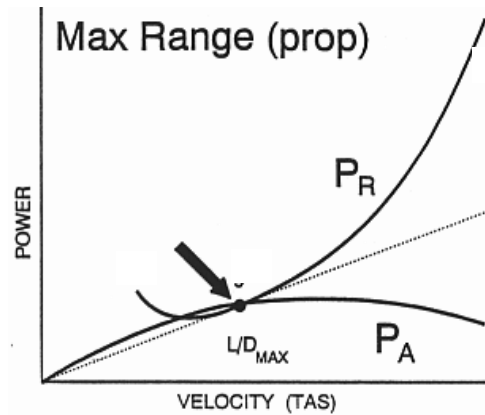

Figure 4-13 Turboprop Maximum Range

As explained previously, if the weight of an airplane increases, the thrust required curve (Figure 4-12) and the power required curve (Figure 4-13) will both shift to the right and up. Since thrust represents fuel flow for a turbojet, as T_R increases so will fuel flow for a turbojet. As P_R increases, fuel flow for a turboprop will also increase. Higher fuel flow means maximum endurance performance will decrease with an increase in weight and max endurance airspeed will increase. The increased fuel flow will also decrease maximum range performance and increase max range airspeed.

An increase in altitude moves the thrust required curve to the right (Figure 4-12) and the power required curve to the right and up (Figure 4-13). However, as altitude increases (sea level to 36,000 ft MSL), the temperature rapidly decreases (to -56.5°C). Decreased temperatures make turbine engines more fuel efficient, requiring less fuel for a given amount of thrust or power. Although the pilot physically increases the throttle setting as altitude increases, fuel flow decreases. Since the airplane is burning less fuel to remain airborne, maximum endurance performance increases with an increase in altitude.

An airplane at a higher altitude will fly at a greater TAS while burning less fuel. Since the fuel consumed per mile flown has decreased, an increase in altitude increases maximum range performance. With the same increase in altitude, turbojet airplane will notice a greater gain in performance than turboprop airplane. This is due in part to the loss of propeller efficiency with altitude.

Configuration changes will affect both max endurance and max range. Lowering the landing gear or flaps causes the thrust required and power required curves to shift up (Figure 4-12 through Figure 4-13). Max endurance and max range will decrease with landing gear and/or flaps extended.

Since range is distance over the ground, ground speed must be considered when determining the effect of wind on maximum range. When flying into a headwind, ground speed is less than true airspeed. Therefore, the range of the airplane decreases since less ground will be covered in a given time. Headwinds will decrease maximum range performance while tailwinds will increase maximum range performance. Winds will have no effect on maximum endurance performance.

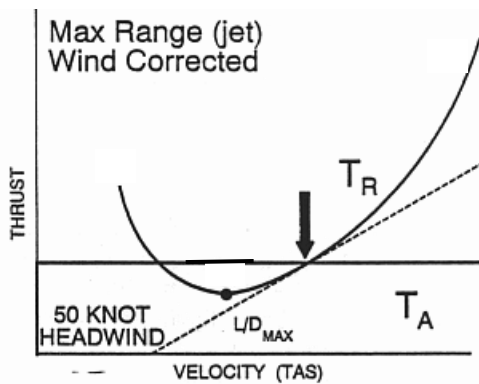

Figure 4-14 Turbojet Maximum Range (Corrected for Headwind)

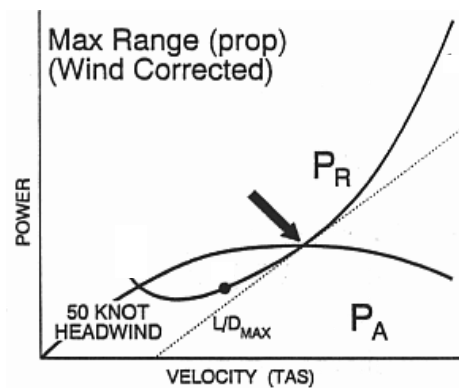

Figure 4-15 Turboprop Maximum Range (Corrected for Headwind)

To partially make up for the decreased performance with a headwind, the pilot can increase the TAS of the airplane. One cannot totally make up for the distance lost, but some of the headwind effect can be overcome. Consider the extreme case of an airplane flying into a headwind that equals TAS. Ground speed and range are zero. Any increase in true airspeed would increase range. The straight line drawn from the origin tangent to the T_R or P_R curve represents a ratio of fuel flow to true airspeed. To make the tangent line represent a ratio of fuel flow to ground speed, one must subtract headwind or add a tailwind to true airspeed. With a headwind, one moves the base of the tangent line to the right of the origin by the amount of the headwind velocity (Figure 4-14 and Figure 4-15). The airspeed at the new

tangent point is the velocity needed to fly maximum range with the headwind. With a tailwind, one moves the base of the tangent line to the left of the origin by the amount of the tailwind velocity.

CEILINGS

As an airplane climbs and P_E decreases, the rate of climb will also decrease. The altitude where maximum power excess allows only 500 feet per minute rate of climb is called the combat ceiling. The cruise ceiling is the altitude at which an airplane can maintain a maximum climb rate of only 300 feet per minute. The service ceiling is the altitude at which an airplane can maintain a maximum rate of climb of only 100 feet per minute. Eventually, the airplane will reach an altitude where maximum power excess is zero. At this altitude, the airplane can no longer perform a steady climb, and its maximum rate of climb is zero. The altitude at which this occurs is called the absolute ceiling. If the airplane flies at its maximum rate of climb velocity, it will only be possible to maintain level equilibrium flight. At any velocity other than this, P_R will exceed P_A , and the airplane will descend. The operational ceiling for the T-6B is 31,000 ft.

GLIDE PERFORMANCE

Gliding is a condition of flight without any operating engine. It does not refer to a single engine failure in a multi-engine airplane. When our engine fails, we may need to glide as far as possible to reach a safe landing area. This is a maximum glide range profile. If we lose power within easy reach of a safe runway, we may decide to fly a maximum glide endurance profile while the runway is being cleared. The equations that represent equilibrium in a glide are (Figure 4-16):

$$L = W \cos \gamma$$

$$D = W \sin \gamma$$

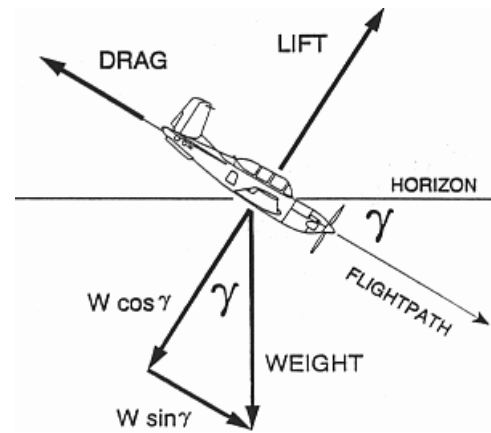

Figure 4-16 Glide Forces

GLIDE RANGE

To achieve maximum glide range, a pilot should maintain the minimum glide angle. Rearranging the above equation:

$$\sin \gamma = \frac{D}{W} = \frac{T_R - T_A}{W} = \frac{T_D}{W}$$

Thus, the angle of descent is directly related to the thrust deficit, T_D . To achieve the minimum angle of descent, we must minimize the thrust deficit, which occurs at L/D_{MAX} (Figure 4-17). Therefore, maximum glide range occurs at L/D_{MAX} . Maximum glide range velocity (V_{BEST}) is L/D_{MAX} for any airplane regardless of engine type. Since the L/D ratio is determined by angle of attack, any change away from L/D_{MAX} AOA would result in a decreased L/D ratio and a decrease in glide range. By holding a constant AOA, we can maintain a constant L/D ratio, regardless of weight or velocity. V_{BEST} is 125 KIAS for the T-6B. Glide range is often expressed as a ratio of horizontal distance to vertical distance. The glide ratio for the T-6B (clean) is 11:1. A glide ratio of 11:1 indicates that an airplane will move forward 11 feet for every foot of altitude lost.

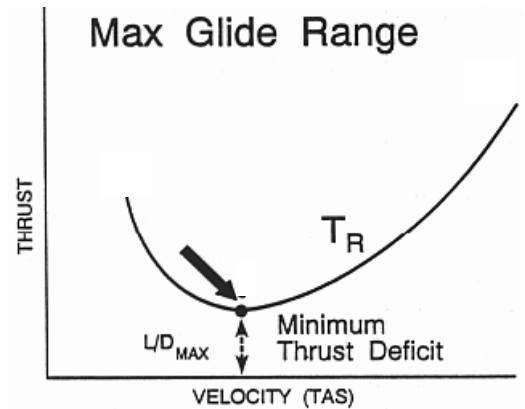

Figure 4-17 Max Glide Range

One might feel a tendency to try to “stretch out” the glide by increasing the angle of attack. If the angle of attack is increased beyond L/D_{MAX} AOA, the horizontal distance the plane will travel will actually decrease. The minimum glide angle obtained at L/D_{MAX} will not produce the minimum sink rate, but will produce the greatest horizontal distance for a given altitude.

GLIDE ENDURANCE

Maximizing glide endurance is simply a matter of minimizing rate of descent (ROD) or negative vertical velocity (Figure 4-18):

$$ROD = V \sin \gamma$$

$$\sin \gamma = \frac{D}{W} = \frac{T_D}{W}$$

By substituting:

$$ROD = V \sin \gamma = \frac{VT_D}{W} = \frac{P_D}{W}$$

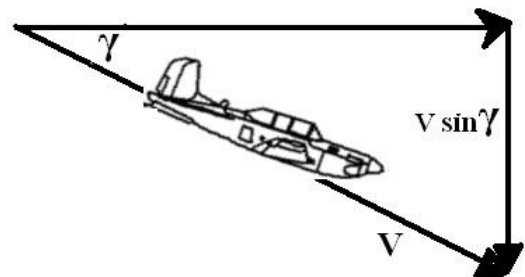

Figure 4-18 Glide Velocity Vectors

To minimize the rate of descent, the pilot must fly at the velocity where the minimum power deficit occurs. This is at the bottom of the P_R curve (Figure 4-19). Maximum glide endurance velocity is less than L/D_{MAX} velocity, and the angle of attack for max glide endurance is greater than L/D_{MAX} AOA.

Glide Performance Factors

As the airplane's weight is increased, the T_R and P_R curves shift up and to the right. The lowest point on each curve will shift as well, increasing the velocity at which it occurs. As long as the pilot maintains L/D_{MAX} AOA, the L/D ratio and angle of descent remain constant. Therefore, an increase in weight will not affect maximum glide range. An increase in the velocity during a descent will cause the rate of descent to increase, and glide endurance to decrease. Increasing the weight will cause the airplane to fly faster and descend faster, but still glide the same distance.

An increase in altitude will increase the maximum glide range and maximum glide endurance of an airplane (Figure 4-20).

Wind has the same effect on maximum glide range that it has on maximum range (Figure 4-21). Since a headwind decreases groundspeed, it causes a decrease in the maximum glide range. Conversely, a tailwind will increase the maximum glide range. Wind has no effect on rate of descent or on glide endurance.

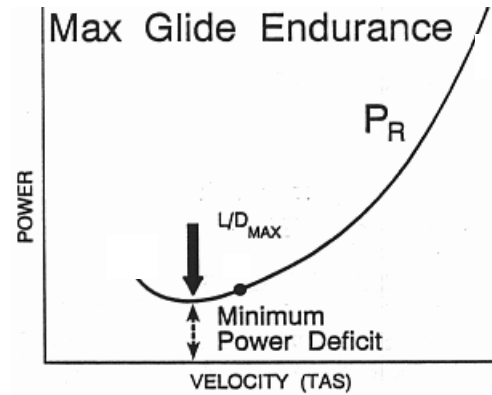

Figure 4-19 Max Glide Endurance

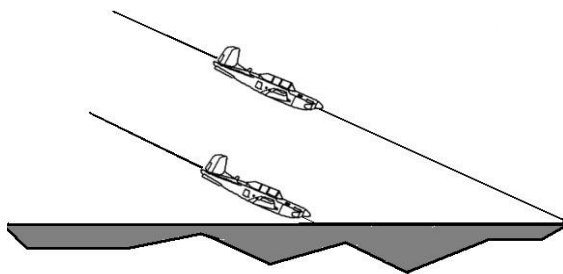

Figure 4-20 Effect of Altitude on Glide

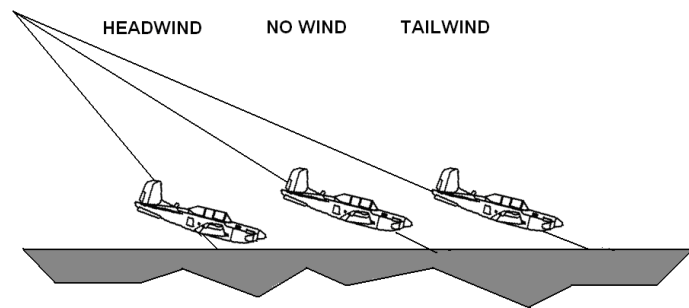
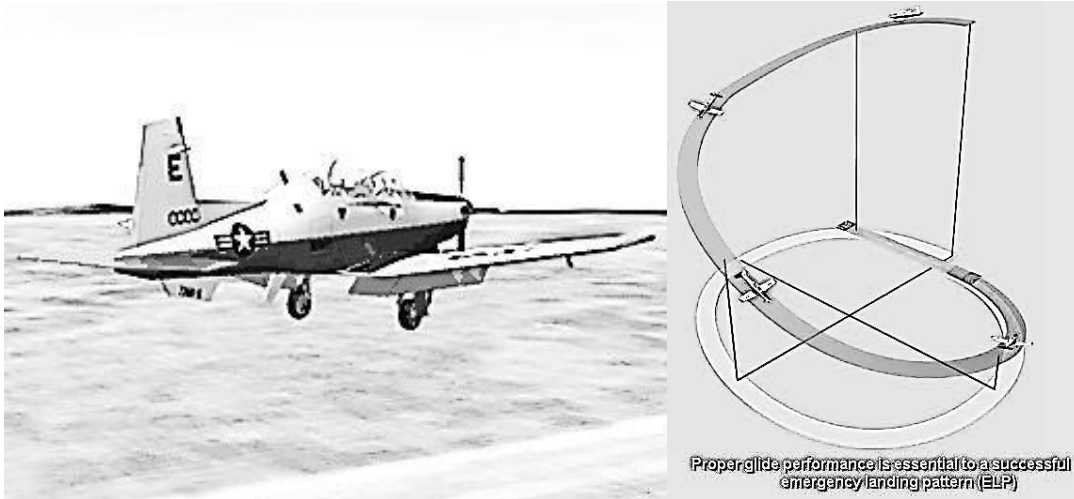

Figure 4-21 Effect of Wind on Glide

During power off flight, airplane configuration plays a major role in determining glide performance. If the pilot alters the configuration by extending the landing gear and/or flaps, the sink rate will increase and glide range will decrease.



The greatest effect of configuration on glide performance deals with the propeller. In normal flight, the propeller blades are almost flat to the relative wind, but create no drag since the engine is driving the prop. When the engine fails, if the propeller blades stay flat to the relative wind, the wind will drive the propeller blades around, a situation called windmilling. Windmilling drastically increases the drag on the airplane and adversely affects glide performance. In order to stop the propeller from windmilling, the individual propeller blades can be turned so they are aligned with the relative wind. This procedure is called feathering the propeller.

THE REGIONS OF NORMAL AND REVERSE COMMAND

Velocities above maximum endurance are referred to as the region of normal command. The region of normal command is characterized by airspeed stability. Assume an airplane is in equilibrium at point B (Figure 4-22 or Figure 4-23). A decrease in airspeed (for example: a headwind gust) results in a thrust or power excess that will eventually accelerate the airplane back to the original airspeed at point B. An increase in airspeed from point B (for example: a tailwind gust) results in a thrust or power deficit that slows the airplane back to the original airspeed.

In the region of normal command, velocity and throttle setting for level flight are directly related. To fly in equilibrium at a faster airspeed, more T_A/P_A is needed than at a slower airspeed. To fly slower, less T_A/P_A is needed.

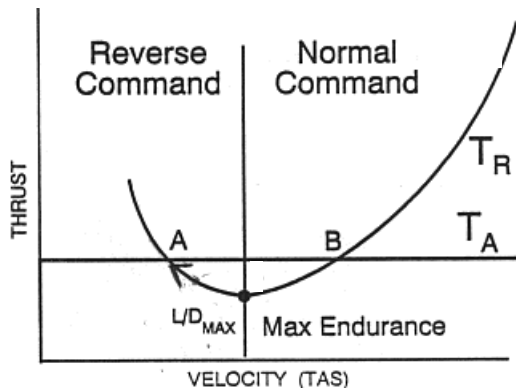

Figure 4-22 Turbojet Reverse Command

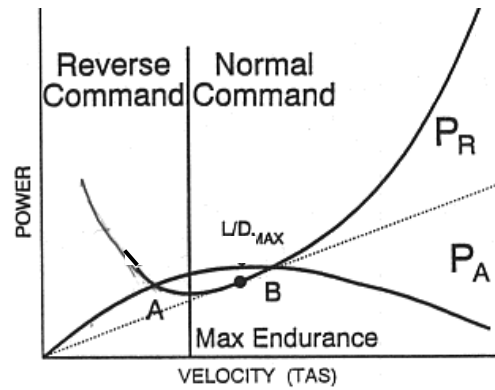

Figure 4-23 Turboprop Reverse Command

Velocities below maximum endurance are referred to as the region of reverse command. The region of reverse command is characterized by airspeed instability. Assume an airplane is in equilibrium at point A (Figure 4-22 or Figure 4-23). A decrease in airspeed (for example: a headwind gust) results in a thrust or power deficit that will eventually slow the airplane to the point of stalling (assuming a level flight attitude is being maintained). An increase in airspeed (for example: a tailwind gust) from Point A results in a thrust or power excess that accelerates the airplane away from point A. The airplane will eventually reach equilibrium at point B.

In the region of reverse command, velocity and throttle setting for level flight are inversely related. Once stabilized at a faster airspeed in equilibrium flight, T_A/P_A will be lower than when stabilized at a slower airspeed. Simply stated, the slower an airplane flies in the region of reverse command, the more thrust and power is needed.

A complete knowledge of this flight region is particularly important because most aviation accidents occur while operating in the region of reverse command. Whenever an airplane is taking off or landing, it is flying in or near this region. A very dangerous situation for an inexperienced pilot is trying to slow down in the region of reverse command. If the pilot increases back pressure to increase angle of attack and decrease velocity, this will cause thrust and power required to increase, creating a deficit. Once the airspeed bleeds off, the deficit causes the airplane to descend. The inexperienced pilot tends to pull back on the control stick in order to keep from descending. This causes the airplane to move further into the region of reverse command, creating a greater deficit. Eventually the deficit will be so great that even full throttle is not able to overcome it. Since this usually occurs during landing, there is not enough altitude to recover. This is the origin of the phrase “behind the power curve.” An experienced pilot knows that in order to maintain level flight as an airplane slows down in the region of reverse command, the throttle must be increased. Increasing angle of attack will only aggravate the situation.

LANDING SPEED

Landing is a transitional maneuver during which the weight of the airplane is shifted from the wings to the landing gear. As with takeoff speed, landing speeds also build in a safety margin above stall speed.

Landing speed is 30 percent higher than stall speed. The extra safety margin is due to the operation at low altitudes with a low power setting. High lift devices are often used to decrease landing speeds. The equations for landing speed are almost identical to takeoff speed:

$$V_{LDG} \approx 1.3 \sqrt{\frac{2W}{\rho S C_{Lmax}}} \quad IAS_{LDG} \approx 1.3 \sqrt{\frac{2W}{\rho_0 S C_{Lmax}}}$$

LANDING FORCES

The same forces that are present during takeoff are present during landing. During the landing roll, thrust and weight still remain nearly constant (reverse thrust is discussed later). Lift and drag are functions of airspeed, so they are greatest immediately upon touchdown and decrease over the remaining landing roll. As lift decreases, weight on wheels increases causing rolling friction to increase. Drag and rolling friction will decelerate the airplane to a safe taxi speed. $D + F_R - T$ is the **net decelerating force**.

LANDING PERFORMANCE

Landing is essentially the reverse of takeoff. The takeoff distance equation requires only slight modifications to be applicable to landing:

$$S_{LDG} = \frac{W^2}{g\rho S C_{Lmax}(F_R + D - T)}$$

The primary consideration in landing is dissipation of the airplane's kinetic energy. Any factor affecting velocity must be considered when trying to reduce the landing distance. Final approach is flown at the lowest velocity feasible. Notice that in the landing distance equation the net accelerating forces are reversed. Drag and rolling friction are now desirable and of course, thrust is not.

An increase in weight will increase landing distance since a greater airspeed is required to support the airplane. An increase in elevation, temperature or humidity will increase landing distance since the reduced density results in a higher landing velocity. High lift devices decrease landing distance because they reduce the ground speed during the landing. A headwind reduces landing distance because it reduces ground speed. A tailwind increases landing distance since it increases ground speed. Charts for predicting takeoff and landing distance are located in the NATOPS manual for each US Navy aircraft ("Dash-1" for USAF aircraft).

The net decelerating force can be increased by use of three different techniques. **Aerodynamic braking** is accomplished by increasing the parasite drag on the airplane by holding a constant pitch attitude after touchdown and exposing more of the airplane's surface to the relative wind. This method of braking helps to reduce wear on the brakes. Drag chutes, spoilers, and speed brakes are also considered aerodynamic braking. Aerodynamic braking is used at the beginning of the landing roll

Mechanical braking (also called frictional or wheel braking) is effective only after enough weight is transferred to the wheels and the airplane has slowed sufficiently. A common procedure is to raise flaps or use spoilers to decrease lift and transfer the airplane’s weight to the wheels when transitioning from aerodynamic to mechanical braking. Mechanical braking is used toward the end of the landing roll.

Some airplanes use **reverse thrust** or **beta** to shorten the landing roll. Thrust is usually negligible after touchdown, but in the case of reverse thrust or “beta” equipped airplanes, thrust increases the net decelerating force.

HYDROPLANING

Hydroplaning causes the airplane’s tires to skim atop a thin layer of water on a runway. If there is standing water in excess of 0.1 inches, hydroplaning may occur. Deeper tread or “channels” that allow water to escape while the tire contacts the runway may require as much as 2 inches of water before hydroplaning occurs. The speed for normal dynamic hydroplaning in mph, can be found using the following formula:

$$V_{hydroplane} = 9\sqrt{tire\ pressure}$$

For knots, divide $V_{hydroplane}$ by 1.15

At first thought, one might think that a heavier airplane would require a faster speed before hydroplaning could occur, but experiments have shown this speed to be independent of weight. Weight only determines the size of the “footprint” that the tire makes. A heavier airplane makes a larger footprint, but the weight supported per square inch of the tire is the same. Weight has no effect on the velocity that an airplane will hydroplane, but a heavier airplane must take off and land at higher speeds which increases the possibility of hydroplaning.

If hydroplaning is suspected, the use of frictional brakes should be minimized, since their use may cause loss of directional control. To minimize the effects of hydroplaning, aircrews should consider factors such as tire condition, touchdown speeds and runway condition when operating on a wet runway. Table 4-1 gives the tire pressure and approximate hydroplaning speeds for the landing gear of the T-6B.

	Pressure	$V_{hydroplane}$
Nosewheel	120±5 psi	85 kts
Main Landing Gear	225±5 psi	115 kts

Table 4-1 T-6B Hydroplaning Speeds

CROSSWINDS

Since winds do not always blow directly down the runway, the possibility of a crosswind takeoff or landing exists. The rudder is the primary means of maintaining directional control in order to compensate for the crosswind during takeoff or landing. Since the rudder loses effectiveness at low airspeeds, the self-centering feature of the T-6B nosewheel provides additional directional stability if the nosewheel is contacting the runway. This enables the pilot to maintain directional control until the rudder becomes effective at higher airspeeds. The pilot must also place the ailerons into the wind during a crosswind takeoff or landing. The ailerons are not used to maintain directional control, but to overcome the lateral stability that is trying to roll the airplane away from the sideslip relative wind (crosswind).

NATOPS and the Dash-1 both contain a Takeoff/Landing Crosswind chart which allows the pilot to determine the minimum safe airspeed that the nosewheel may leave the runway during takeoff, or the minimum airspeed at which the nosewheel must return to the runway following a landing. Lifting the nosewheel below the minimum **nosewheel liftoff/touchdown (NWLO/TD) speed** may cause the airplane to weathercock or weathervane into the wind and possibly run off the runway.

Many airplanes have maximum crosswind limits that are based upon minimum nosewheel liftoff/touchdown speed. The major consideration for determining maximum authorized crosswind components is the ability to maintain directional control at low speeds. Maximum crosswind component for a takeoff or landing in the T-6B is 25 knots. For variable or gusting winds, always use the maximum wind angle and the maximum gust velocity given to determine the crosswind component.

PROPELLER

TORQUE

Torque is a reactive force based on Newton's Third Law of Motion. A force must be applied to the propeller to cause it to rotate clockwise. A force of equal magnitude, but opposite direction, is produced which tends to roll the airplane's fuselage counter-clockwise. In the T-6B, rudder and the automatic Trim Aid Device (TAD) are the primary means of compensating for engine torque.

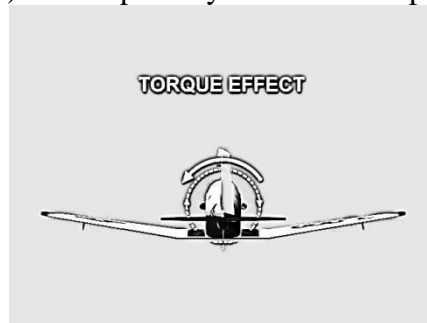

A turbojet aircraft will not experience torque from its engines. Jet engines do not push against the airframe in order to rotate, they rest on bearings and push against the airflow to rotate. The torque in a turboprop is applied through its gearbox, not its engine.

P-FACTOR

Propeller factor (P-factor) is the yawing moment caused by one prop blade creating more thrust than the other. The angle at which each blade strikes the relative wind will be different (Figure 4-24), causing a different amount of thrust to be produced by each blade. For practical purposes, only the up-going and down-going blades are considered. If the relative wind is above the thrust line, the up-going propeller blade on the left side creates more thrust since it has a larger angle of attack with the relative wind. This will yaw the nose to the right (Figure 4-25). Note that this right yaw will result at high airspeeds due to the slight nose-down attitude required in level flight. If the relative wind is below the thrust line, such as in flight near the stall speed, the down-going blade on the right side will create more thrust and will yaw the nose to the left.

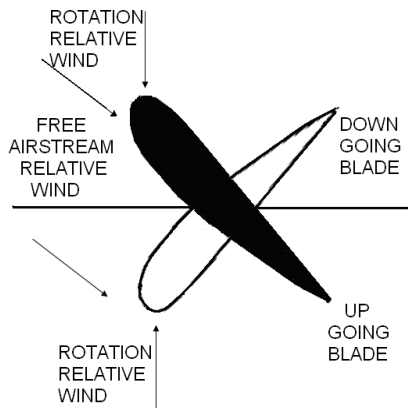

Figure 4-24 Propeller Side View

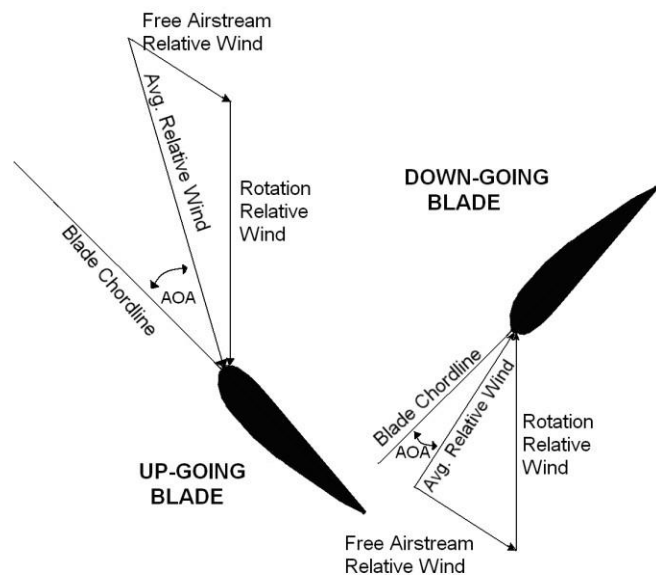
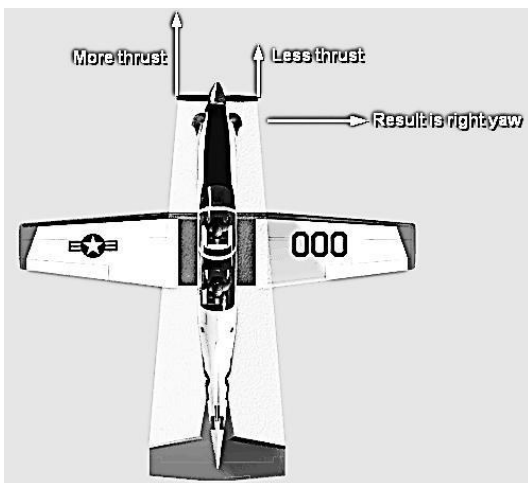

Figure 4-25 Relative Wind (Nose-Down Attitude)



There are two basic requirements for P-factor to have a noticeable effect: The engine must be set to a high power condition, and the thrust axis must be displaced from the relative wind. Since airplane designers want P-factor to be minimized during the majority of flight, they align the thrust axis with the relative wind for cruise airspeeds. Thus, P-factor will be most prevalent at AOAs significantly different from cruise AOA, such as very high speed level or descending flight, and high angle of attack climbs.

SLIPSTREAM SWIRL

The propeller imparts a corkscrewing motion to the air called the slipstream swirl. This corkscrewing air flows around the fuselage until it reaches the vertical stabilizer where it increases the AOA on the vertical stabilizer (Figure 4-26). When a propeller driven airplane is at a high power setting and low airspeed (e.g., during takeoff), the increased angle of attack creates a horizontal lifting force that pulls the tail to the right and causes the nose to yaw left. Right rudder and lateral control stick inputs are required to compensate for slipstream swirl.

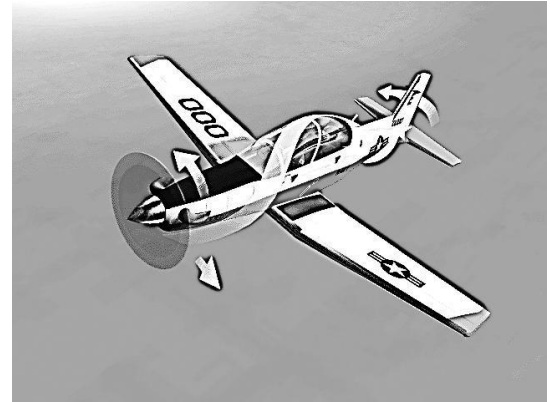

Figure 4-26 Propeller Slipstream Swirl

GYROSCOPIC PRECESSION

Gyroscopic precession is a consequence of the properties of spinning objects. When a force is applied to the rim of a spinning object (such as a propeller) parallel to the axis of rotation, a resultant force is created in the direction of the applied force, but occurs 90° ahead in the direction of rotation (Figure 4-27). Pitching the nose of the T-6B down produces an applied force acting forward on the top of the propeller disk. The resultant force would act 90° ahead in the direction of propeller rotation (clockwise), and cause the T-6B to yaw left. Gyroscopic precession often plays a large role in determining an airplane's entry characteristics into a spin.

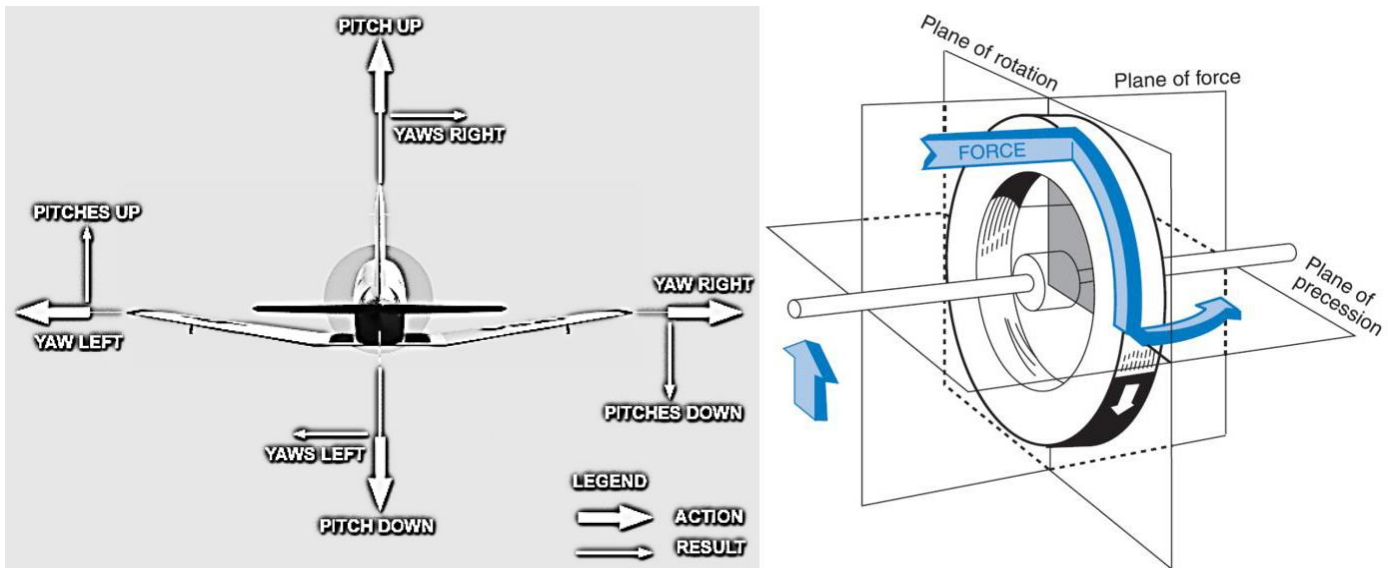

Figure 4-27 Gyroscopic Precession

MANEUVERING FORCES

Turning flight is described as changing the direction of the airplane's flight path by reorienting the lift vector in the desired direction. During a turn, the lift vector is divided into two components, a horizontal component (L_H) and a vertical component (L_V) (Figure 4-28). The horizontal component of lift, called centripetal force, accelerates the airplane toward the inside of the turn. In straight and level flight (constant altitude, constant direction) total lift is equal to weight, but in a turn, only the vertical component of the lift vector opposes weight. If the pilot does not increase the total lift vector, the airplane will lose altitude because weight will be greater than L_V . The increased lift is normally obtained by increasing the angle of attack, i.e. pulling back on the stick.

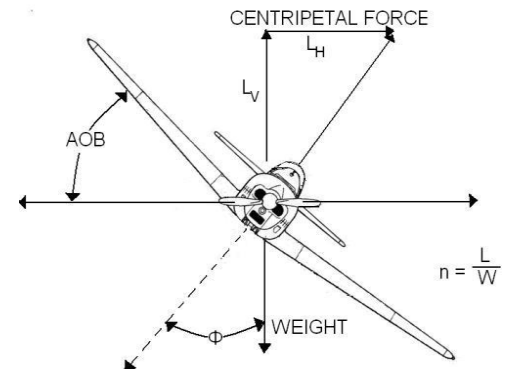

Figure 4-28 Turning Flight

Increasing the lift produced by the wings increases the load on the airplane. **Load factor (n)** is the ratio of total lift to the airplane's weight. It is sometimes called Gs since it is measured as the number of times the earth's gravitational pull felt by the pilot. For example, a 3,000 pound airplane in a 60° angle of bank turn must produce 3,000 pounds of vertical lift to maintain altitude. Therefore, the wings must produce 6,000 pounds of total lift so the airplane experiences a load on its wings that is twice the force due to gravity, or 2 Gs. One "G" is what we experience just sitting or walking.

$$n = \frac{L}{W} \quad \text{or} \quad L = W \cdot n$$

In maneuvering flight, the amount of lift produced by an airplane is equal to its weight (W) multiplied by its load factor (n). By substituting $W \cdot n$ into the lift equation and solving for V , we can derive an equation for stall speed during maneuvering flight. This is called **accelerated stall speed** because it represents the stall speed at velocities greater than minimum straight and level stall speed, and load factors greater than one. Phi (ϕ) is the angle of bank associated with the load factor (n).

$$V_{S\phi} = \sqrt{\frac{2Wn}{\rho S C_{L \max}}} \quad IAS_{S\phi} = \sqrt{\frac{2Wn}{\rho_0 S C_{L \max}}}$$

Maneuvering the airplane will significantly affect stall speed. Stall speed increases when we induce a load factor greater than one on the airplane. Figure 4-29 is a generic chart that can be used for any fixed wing aircraft and assumes a constant altitude turn. It lists the load factors and percent increase in stall speed for varying angles of bank. Notice that above 45° angle of bank the increase in load factor and stall speed is rapid. This emphasizes the need to avoid steep turns at low airspeeds. An airplane in a 60° angle of bank experiences 2 Gs, but has an accelerated stall speed that is 40% greater than wings level stall speed.

A quick method for calculating accelerated stall speed is to round your normal stall speed off to a higher, round number and multiply it by the square root of the number of Gs sustained. For example, if stall speed is 92 kts and a 2 G maneuver is performed, accelerated stall speed can be estimated by rounding 92 kts up to 100 kts, then multiplying by the square root of two (1.4).

As the load factor approaches three Gs, the pilot will notice a sensation of blood draining from the head and a tendency for his or her face to sag. Further increases in G loading may cause the pilot to gray out or even temporarily lose consciousness if the pilot does not correctly apply the anti-G straining maneuver. As the load factor approaches negative three Gs, the pilot will notice a sensation of blood rushing to his head, and the face and eyeballs will feel like they are bulging out. Exceeding negative three Gs may cause one to “red out” or suffer from bursting blood vessels.

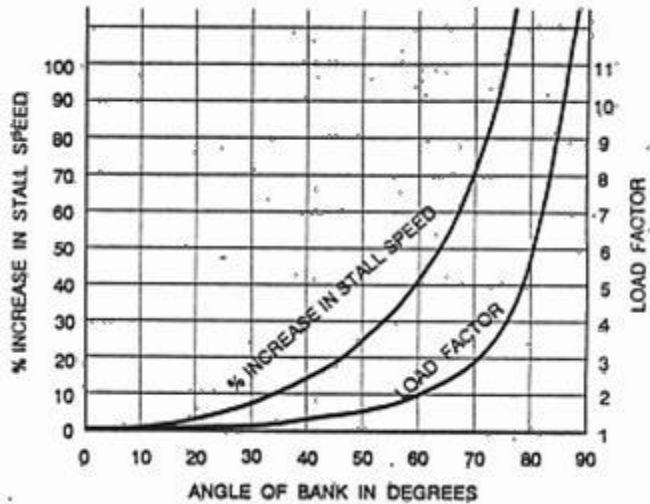

Figure 4-29 Stall Speed vs. AOB

TURN PERFORMANCE

Turn performance is measured using two different parameters, turn rate and turn radius. **Turn rate** (ω) is the rate of heading change, measured in degrees per second. **Turn radius** (r) is a measure of the radius of the circle the flight path scribes. Turn performance in a level coordinated turn is controlled only by airspeed and angle of bank. Weight, altitude, load factor, stalling angle of attack, engine performance, and wing loading may limit either the airspeed or angle of bank. This would limit maximum turn rate or minimum turn radius, however, the actual performance would still be determined using only airspeed and angle of bank. The formulas for determining the turn rate and turn radius for an airplane in coordinated flight are:

$$\omega = \frac{g \tan\phi}{V} \quad r = \frac{V^2}{g \tan\phi}$$

where ω = turn rate, r = turn radius, V = velocity, θ theta = angle of bank and g = gravity.

If velocity is increased for a given angle of bank, turn rate will decrease, and turn radius will increase. An example of this would be turning a very sharp corner on a bicycle at 5 mph versus trying to turn the same corner at 30 mph. If angle of bank is increased for a given velocity, turn rate will increase, and turn radius will decrease.

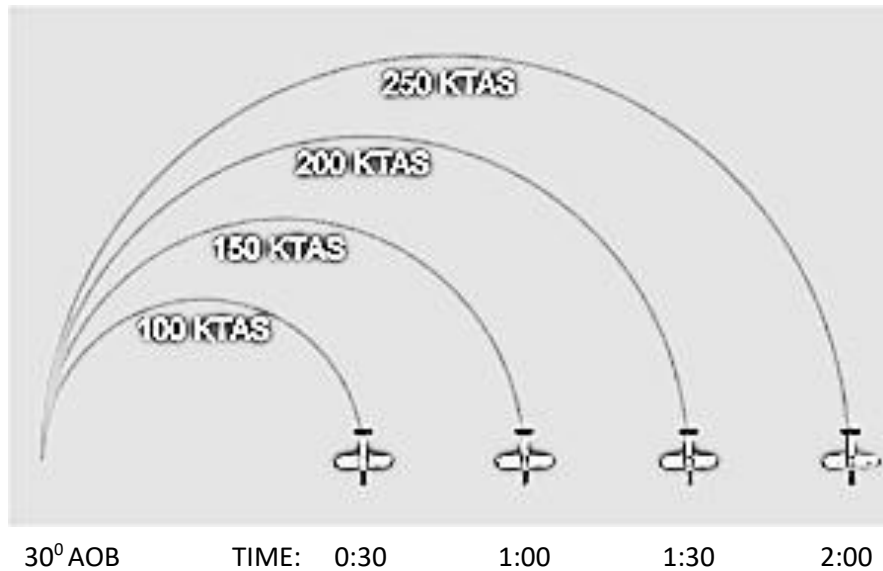

The maximum turn rate and minimum turn radius would be achieved in a 90° angle of bank turn, at the airplane's minimum velocity. However, there are limits on angle of bank and velocity. Minimum velocity, stall speed, is determined by $C_{L_{max}}$ AOA. Maximum turn performance will be achieved at the accelerated stall speed for whatever angle of bank is being flown. An increase in angle of bank increases the accelerated stall speed, and vice versa.

If an airplane's limit load is 2 Gs, the maximum angle of bank that it could maintain will be 60 degrees (Figure 4-29). With a limit load factor of 7 Gs, the T-6B is limited to about 83 degrees angle of bank in level flight.

An airplane's thrust limit may also limit its turn performance. Since induced drag is directly proportional to lift squared, an airplane pulling 5 Gs would produce 25 times as much induced drag as in level flight. If the maximum thrust available can only overcome 16 times as much induced drag, then the airplane can only maintain level flight at 4 Gs.

Of the three factors that limit turn performance, $C_{L_{max}}$ AOA and the limit load factor are found on the V-n diagram at the maneuver point. Assuming the airplane's angle of bank is not thrust limited, this is where maximum turn performance is achieved. Any deviation from the maneuver point produces an undesired result. If velocity increases at a constant load factor, turn rate will decrease and turn radius will increase. If velocity decreases at a constant load factor, the airplane will stall. If angle of bank (limit load) increases at a constant velocity, the airplane will stall. If angle of bank (limit load) decreases at a constant velocity, turn radius will increase and turn rate will decrease.

Turn rate and turn radius are independent of weight. Any two airplanes capable of flying at the same velocity and same angle of bank can fly in formation, regardless of their weights. The load factor and turn performance for both airplanes will be the same, although the heavier airplane will be producing more lift.

Instrument flight requires that turns be made at a standard rate. A **Standard Rate Turn (SRT)** is one in which 3° of turn are completed every second. As airspeed increases, the turn radius of a SRT will

increase. A Standard Rate Turn in the T-6B corresponds to two needle widths' deflection on the turn needle.

COORDINATED TURNS

The turn-and-slip indicator gives the pilot a visual indication of coordinated flight. It consists of a turn needle and a ball suspended in fluid. If the ball is centered, the aircraft is in coordinated flight (Figure 4-30). If the ball is displaced in the same direction as the turn, the aircraft is in a slip. If the ball is displaced in the opposite direction as the turn, the aircraft is in a skid.

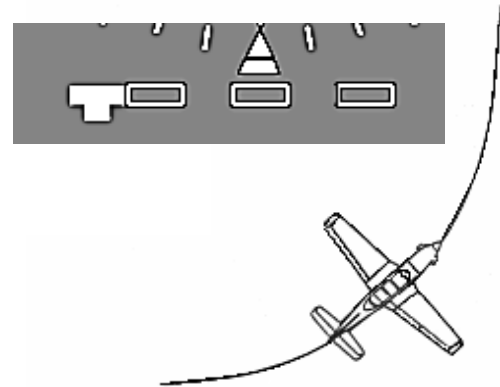

Figure 4-30 Coordinated Turn

Whenever the aircraft becomes uncoordinated during flight, the corrective action is to alter the amount of rudder being used. This simply means to apply rudder in the direction the ball is displaced. Therefore, if the ball is displaced to the right, apply right rudder. A useful mnemonic device for proper rudder correction is “step on the ball.”

A **skid** is caused by using too much rudder in the desired direction of turn (Figure 4-31). The yawing movement is toward the inside of the turn and the balance ball is deflected toward the outside due to centrifugal force. In a skid, turn radius will decrease and turn rate will increase. Skids are dangerous because the airplane will roll inverted if stall occurs (a skidded turn stall). Such a stall will probably be fatal at low altitude.

A **slip** is caused by opposite or insufficient rudder in the desired direction of turn (Figure 4-32). The yawing movement is toward the outside of the turn, and the balance ball is deflected toward the inside, due to gravitational pull. In a slip, turn radius will increase and turn rate will decrease. Slips are useful for crosswind landings (commonly described as “wing down, top rudder”), or when trying to increase the airplane rate of descent without increasing airspeed. A stall while in a slip will cause the airplane to roll toward wings level (a safer reaction than in a skid). Still, any stall at low altitude could be fatal.

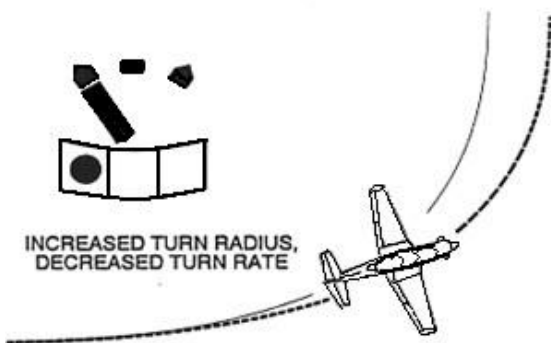

Figure 4-31 Slip

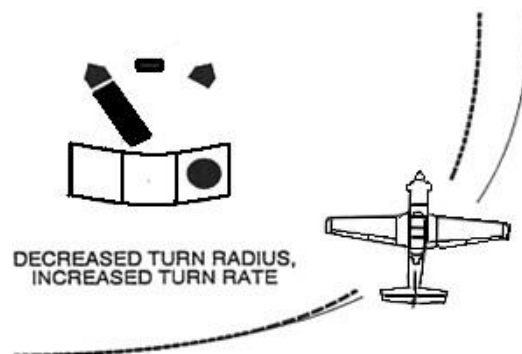

Figure 4-32 Skid

THE APPROACH TURN

At this point, it is important to understand how the aircraft's turning limitations affect flying the approach turn. The approach turn is a critical phase of flight where disregard for aerodynamic limitations can result in disaster.

Increased Gs are required as bank angle increases during a level turn. This also applies during constant descents such as the approach turn. Increased load factors result in increased stall speed (Figure 4-30). Many pilots have made the fatal mistake of excessively increasing bank and back pressure during the approach turn in an effort to avoid overshooting the runway. They stall the aircraft, and depending upon the nature of the aircraft, the power response time, altitude, and the stall recognition point, the aircraft may not be recoverable prior to ground impact.

This situation can easily be avoided. First, pattern winds should be analyzed and the pattern planned so that an excessively tight approach turn will not be required. Second, if faced with an overshooting final approach, the pilot should initiate a go-around/off and re-attempt the turn with safe amounts of bank and back pressure.

DEFINITIONS

A **load** is a stress-producing force that is imposed upon an airplane or component. **Strength** is a measure of a material's resistance to load. There are two types of strength: Static strength and fatigue strength. **Static strength** is a measure of a material's resistance to a single application of a steadily increasing load or force. **Static failure** is the breaking or serious permanent deformation of a material due to a single application of a steadily increasing load or force. For instance, a pencil breaks when too much force is applied and its static strength is exceeded.

Fatigue strength is a measure of a material's ability to withstand a cyclic application of load or force, i.e., numerous small applications of a small force over a long period of time. **Fatigue failure** is the breaking (or serious permanent deformation) of a material due to a cyclic application of load or force. Breaking a wire coat hanger by bending it back and forth demonstrates fatigue failure. Airplanes may experience fatigue failure on many components (landing gear struts, tailhooks, and mounting brackets) due to the numerous arrested landings, catapult shots, and high G maneuvers performed in normal operation. The components are designed to withstand repeated loads, but not forever. **Service life** is the number of applications of load or force that a component can withstand before it has the probability of failing. Fatigue strength plays a major role in determining service life. Service life may apply to an individual component, or to the entire airframe.

When a metal is subjected to high stress and temperature it tends to stretch or elongate. This is called plastic deformation or **creep**. Engine turbine blades are periodically monitored for creep damage due to high heat and stress. Modern supersonic aircraft may also suffer from creep damage on the skin of the airplane, especially on the leading edge of the wings.

The structural limits of an airplane are primarily due to the metal skeleton or airframe. Any time a wing produces lift, it bends upward. The wing may permanently deform if lift becomes too great. Airframe components, particularly the wings, determine the maximum load that the airplane can withstand. The two greatest loads on an airplane are lift and weight. Since weight doesn't vary greatly from one

moment to the next, lift will be the force that causes the maximum load to be exceeded.

It is difficult to measure the amount of lift produced by the airplane, but it is relatively easy to measure acceleration. Since acceleration is proportional to force (Newton's Second Law), and we know the weight of the airplane, we can determine the amount of lift by monitoring the airplane's acceleration. Since load factor is a ratio of an airplane's lift to its weight, and the mass being accelerated by lift and weight is the same mass, load factor is actually the acceleration due to lift expressed as a multiple of the earth's acceleration, and can easily be measured by an accelerometer.

Structural considerations determined by the airplane's mission and desired service life force a manufacturer to meet certain limits, such as maximum load factor, airspeed and maneuvering limitations. These design limits include the limit load factor, ultimate load factor, redline airspeed and maneuvering parameters.

Limit load factor is the greatest load factor an airplane can sustain without any risk of permanent deformation. It is the maximum load factor anticipated in normal daily operations. If the limit load factor is exceeded, some structural damage or permanent deformation may occur. Aircraft will have both positive and negative limit load factors. The T-6B's limit load factor is at +7 Gs and -3.5 Gs.

Overstress/Over-G is the condition of possible permanent deformation or damage that results from exceeding the limit load factor. This type of damage will reduce the service life of the airplane because it weakens the airplane's basic structure. Overstress/over-g may occur without visibly damaging the airframe. Inside the airplane are a variety of components, such as hydraulic actuators and engine mounts, which are not designed to withstand the same loads that the airframe can. Before the airframe experiences static failure these components may break if overstressed. The wing will not depart the airplane if the limit load factor is exceeded, but if an engine mount breaks, a fire could result from fuel spewing on hot engine casing. Any time an airplane experiences an overstress, maintenance personnel must inspect to determine whether damage or permanent deformation actually occurred. Always report an overstress/over-G to maintenance. Whether or not deformation or damage occurs depends on the elastic limit of the individual components.

If a rigid metal object, such as a wing, is subjected to a steadily increasing load, it will bend or twist. When the load is removed, the component may return to its original shape. The **elastic limit** is the maximum load that may be applied to a component without permanent deformation. When a component is stressed beyond the elastic limit, it will experience some permanent deformation, but may still be usable. If the force continues to increase, the component will break. To ensure the airplane may operate at its limit load factor without permanent deformation, the limit load factor is designed to be less than the elastic limit of individual components. This virtually guarantees the airplane will reach its expected service life.

Ultimate load factor is the maximum load factor that the airplane can withstand without structural failure. There will be some permanent deformation at the ultimate load factor, but no actual failure of the major load-carrying components should occur. If you exceed the ultimate load factor, structural failure is imminent (something major on the airplane will break). The ultimate load factor should be avoided since the typical airplane is rather difficult to fly after its wings tear off. The ultimate load

factor is 150% of the limit load factor.

V-N / V-G DIAGRAM

The **V-n diagram** or **V-G diagram** is a graph that summarizes an airplane's structural and aerodynamic limitation. The horizontal axis is indicated airspeed, since this is what we see in the cockpit. The vertical axis of the graph is load factor, or Gs. The V-n diagram represents the maneuvering envelope of the airplane for a particular weight, altitude, and configuration.

Accelerated stall lines, or lines of maximum lift, represent the maximum load factor that an airplane can produce based on airspeed. The accelerated stall lines are determined by $C_{L_{max}}$ AOA. They are the curving lines on the left side of the V-n diagram (Figure 4-33). If one tries to maintain a constant airspeed and increase lift beyond the accelerated stall lines, the airplane will stall because we have exceeded the stalling angle of attack. As airspeed increases, more lift can be produced without exceeding the stalling angle of attack.

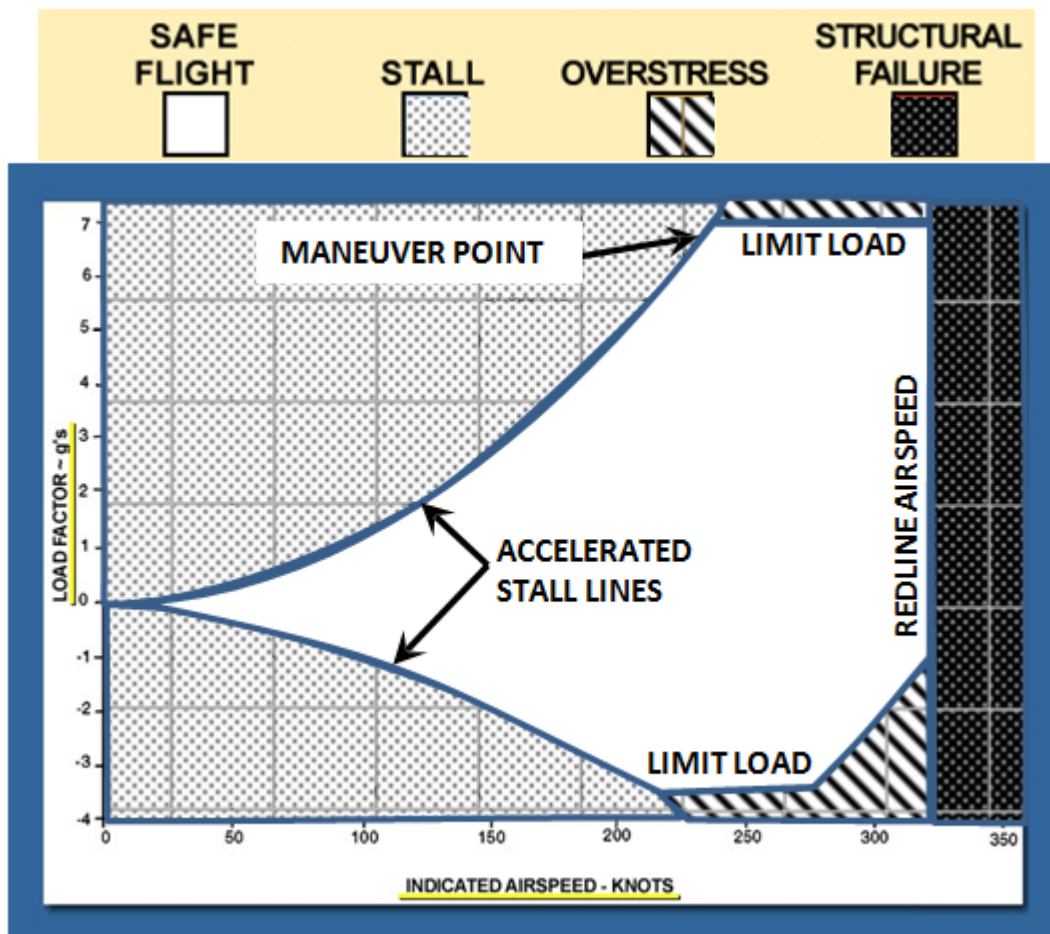

Figure 4-33
Example V-n Diagram

The limit load factors and ultimate load factors, both positive and negative, are plotted on the diagram. These lines represent the manufacturer's and the military's structural limitations. Any G load above the limit load factor will overstress the airplane. Any G load above the ultimate load will cause structural failure. Notice that the positive and negative limit load factors are different. Since the pilot cannot sustain a negative acceleration much greater than three Gs, the designer can save some structural weight by reducing the airplane's ability to sustain negative Gs. For this reason, most maneuvers are performed with positive accelerations.

The point where the accelerated stall line and the limit load factor line intersect is called the **maneuver point**. The IAS at the maneuver point is called the **maneuver speed (V_a)** or **cornering velocity**. It is the lowest airspeed at which the limit load factor can be reached. Below the maneuver speed, we can never exceed the limit load factor because the airplane will stall before the limit load factor is reached. The T-6B's maneuver speed is 227 KIAS at maximum gross weight.

The vertical line on the right side is called the **redline airspeed**, or V_{NE} (Velocity never-to-exceed). Redline airspeed is the highest airspeed that an airplane is allowed to fly. Flight at speeds above V_{NE} can cause structural damage. V_{NE} is determined by one of several methods: **Critical Mach Number (M_{CRIT})**, airframe temperature, excessive structural loads, or controllability limits.

MACH NUMBER

$$M = \frac{TAS}{LSOS}$$

Mach number represents the ratio of an airplane's speed through a given air mass to sound's speed through the same air mass. An airplane traveling at Mach 1 is moving exactly as fast as sound is moving through the same air. An airplane's Critical Mach Number is the lowest Mach number that an airplane can travel and create sonic (Mach 1) airflow somewhere on the aircraft.

Because not all airplanes are designed to deal with stresses of breaking the sound barrier, care must be taken to ensure that airplanes not intended for supersonic (Mach 1+) flight remain below their critical Mach number. Since airplanes typically climb at a constant indicated airspeed, this becomes very important at higher altitudes. Recall the TAS equation. As an airplane climbs, air density decreases, and a pilot must fly at a higher true airspeed to maintain the same indicated airspeed. As altitude increases, temperature also decreases which causes sound to travel slower. Both of these changes will cause Mach number to increase with an increase in altitude. Since Critical Mach Number is based on an airplane's design, which does not change with altitude, as a pilot climbs they may eventually reach a point where they must transition from a constant indicated airspeed climb to a constant Mach number climb to avoid catastrophic airframe damage.

If an airplane reaches its critical Mach number (M_{CRIT}), and is not designed to withstand supersonic airflow, the shock waves generated may damage the structure of the airplane. Redline airspeed for these aircraft will be slightly below the airspeed at which they will achieve M_{CRIT} . Turboprop aircraft must also take M_{CRIT} for the propeller into account as well. It is crucial that propeller blades not exceed the LSOS, otherwise, catastrophic failure of the blades can occur.

Redline airspeed may also be used to set limits on airframe temperature. As airspeed increases, the airplane encounters more air particles producing friction which heats up the airframe. This heating

can be extreme and hazardous at high speeds. Once the temperature becomes excessive, the airframe may suffer creep damage.

Excessive structural loads may be encountered on components other than the main structural members. Control surfaces, flaps, stabilizers, and other external components are often not able to withstand the same forces that the wings or fuselage can withstand.

Deflecting control surfaces at very high airspeeds may create sufficient forces to twist or break the wing or stabilizer on which they are located. The maximum operating airspeed for the T-6B is 316 KIAS or .67 Mach, whichever is less

Controllability may determine the redline airspeed on aircraft with conventional control systems. At high airspeeds, dynamic pressure may create forces on the control surfaces which exceed the pilot's ability to overcome. Or, due to the aeroelasticity of the controls surfaces, full deflection of the cockpit controls may cause only small deflection of the control surfaces. In either case, the pilot will be unable to provide sufficient control input to safely maneuver the airplane.

FACTORS AFFECTING THE SAFE FLIGHT ENVELOPE

The portion of the V-n diagram that is bounded by the accelerated stall lines, the limit load factors and redline airspeed is called the **safe flight envelope**. The five major factors affecting the safe flight envelope are gross weight, altitude, configuration, asymmetric loading, and gust loading.

The gross weight of an airplane will affect the airplane's limit load factor and ultimate load factor. Consider an airplane whose wing is built to withstand 20,000 pounds of static load; this will determine how many Gs can be pulled. If the airplane takes off with a weight of 5,000 pounds, it could withstand 4 Gs ($20,000 / 5,000 = 4$). If the airplane weight decreases by burning fuel or expending ordnance, the limit load factor will increase. If the same airplane decreased its weight to 4,000 pounds, it could now withstand 5 Gs. An increase in weight will also cause the accelerated stall lines to sweep to the right since an increase in weight increases an airplane's stall speed. This causes the maneuver speed to increase (Figure 4-34). Weight generally does not affect redline airspeed. Since its weight changes are small compared to other aircraft, they are not accounted for in the T-6B's safe flight envelope.

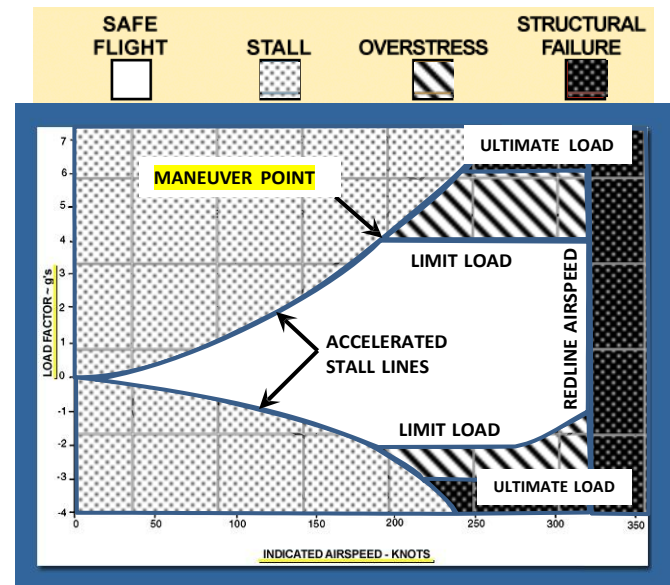

Figure 4-34 Effect of Increased Gross Weight

As altitude increases, the speed of sound will decrease and TAS will increase for a given IAS. With an increase in altitude the indicated redline airspeed must decrease in order to keep a subsonic airplane below M_{CRIT} TAS. Since the limit and ultimate load factors are structural limits, they do not change with altitude. Since the horizontal axis is indicated airspeed, the accelerated stall lines will not change (Figure 4-35).

Another factor that affects the safe flight envelope is configuration. When the landing gear and high lift devices are extended; the envelope is substantially reduced in size. This is mainly due to the relatively weak structure of the landing gear doors and the deployed high lift devices. High airspeeds could possibly tear the landing gear doors off or bend the flaps. An airplane in the landing

configuration does not need to maneuver at high speeds and create high G loading. Changing the configuration by adding external stores, such as weapons or drop tanks, may also reduce redline airspeed because the higher air loads imposed may tear them from the airplane (Figure 4-36).

Asymmetric loading refers to uneven production of lift on the wings of an airplane. It may be caused by a rolling pullout, trapped fuel, or hung ordnance. The V-n diagram may reflect limits that are imposed because of this condition (Figure 4-37). When an airplane is rolling, the up-going wing is producing more lift than the down-going wing. If the airplane performs a rolling pullout, the up-going wing may become overstressed even though the accelerometer in the cockpit shows a G load at or below the limit load factor. This would be aggravated even further if there were an imbalance of ordnance or fuel on the wings. For this reason, in all maneuvers requiring a pullout at higher than normal loading, one of the first steps is to always level the wings. If the pilot were to experience an asymmetric load after a bombing run, e.g., hung ordnance, special attention must be paid to the amount of Gs and angle of bank. Because asymmetric loading is cumulative with pilot induced loading, the limit load factor due to pilot induced loads should be reduced to approximately two-thirds of the normal limit load factor. This will ensure that one wing is not overstressed. In the T-6B, the maximum load factor during asymmetric loading is +4.7 to -1.0 Gs.

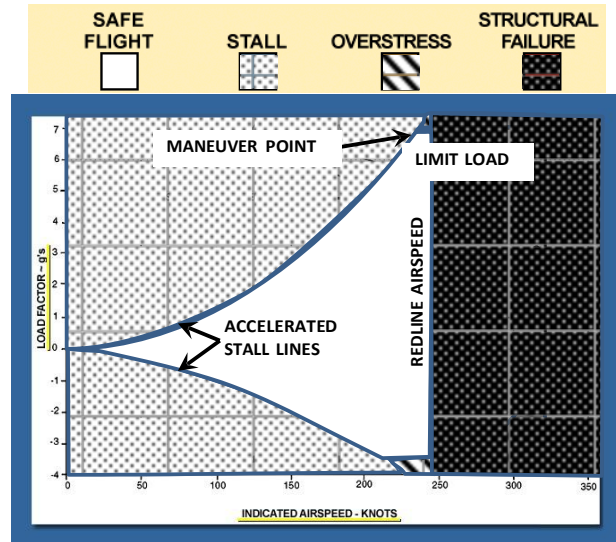

Figure 4-35 Effect of Increased Altitude

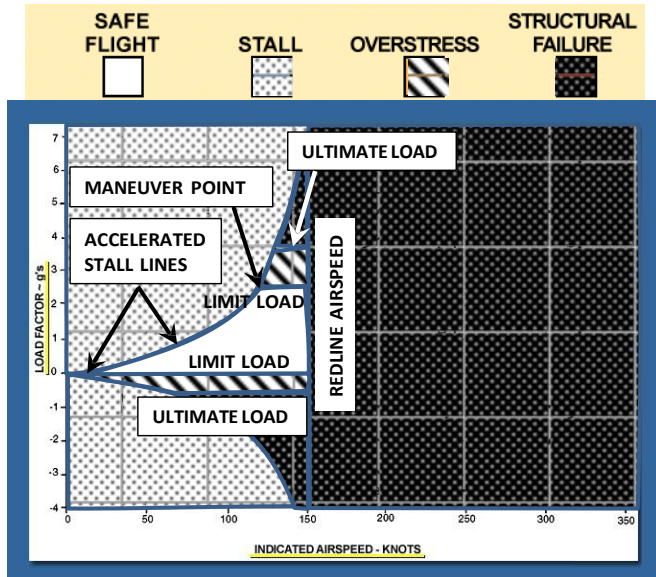

Figure 4-36 Effect of Configuration

Gust loading refers to the increase in the G load due to vertical wind gusts. The load imposed by a gust is dependent upon the velocity of the gust: the higher the velocity, the greater the increase in load. If an airplane were generating the limit load factor during a maximum performance turn and hit a vertical gust, the gust would instantaneously increase the angle of attack of the airfoils and increase the lift on the wings enough to raise the G load above the limit load factor. For this reason, intentional flight through forecasted severe or reported moderate turbulence is prohibited in the T-6B.

Vertical gusts of up to 30 feet per second may be encountered in moderate turbulence. This could produce up to 2 Gs of acceleration on the airplane. Because gust loading is cumulative with pilot induced loading, the limit load factor due to pilot induced loads should be reduced to two-thirds of the normal limit load factor.

Turbulence penetration also requires that you slow the airplane to a speed that will reduce the effects of stress caused by gust loading. NATOPS states that the maximum airspeed for the T-6B in turbulence is 207 KIAS, and the recommended airspeed is 180 KIAS. When entering severe or extreme turbulence, the pilot should slow to an airspeed less than this. Maneuver speed is normally what the manufacturer recommends because the airplane cannot be overstressed for positive Gs at that airspeed. At a slower airspeed the aircraft will stall more easily; it makes no sense to spend more time than necessary in the turbulence.

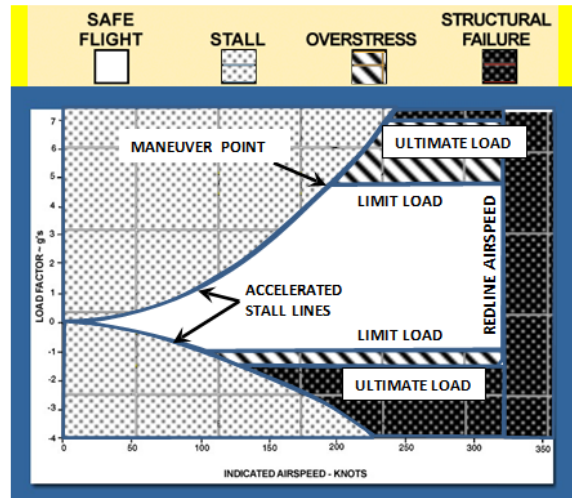

Figure 4-37 Effect of Asymmetric Loading or Gust Loading

Stability

Types Of Stability

Stability is the tendency of an object to return to its state of equilibrium once disturbed from it. There are two kinds of stability: static and dynamic. **Static stability** is the initial tendency of an object to move toward or away from its original equilibrium position. **Dynamic stability** is the position with respect to time, or motion of an object after a disturbance.

Static Stability

If an object has an initial tendency toward its original equilibrium position after a disturbance, it is said to possess **positive static stability**. Consider a ball inside a bowl (Figure 4-38). The ball's equilibrium position is at the bottom of the bowl. If the ball is moved from this position toward the rim of the bowl, its initial tendency, when released, is to roll back toward the bottom of the bowl. It is therefore said to possess positive static stability.

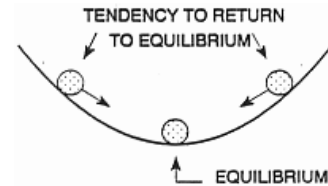

Figure 4-38 Positive Static Stability

Negative static stability is the initial tendency to continue moving away from equilibrium following a disturbance. Consider the bowl upside down with the ball on top as in Figure 4-39. Observe the ball's new equilibrium position. If the ball is moved away from its equilibrium position and released, its initial tendency is to roll farther away from equilibrium. The ball exhibits negative static stability.

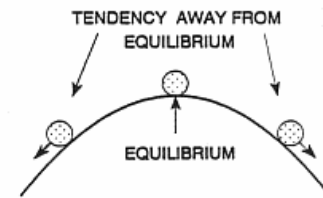

Figure 4-39 Negative Static Stability

Neutral static stability is the initial tendency to accept the displacement position as a new equilibrium. If we place the ball on a flat surface, it is again in equilibrium. If it is moved away from its original spot, the ball adopts the new equilibrium position (Figure 4-40). It does not have a tendency to move toward or away from the original equilibrium position. The ball now demonstrates neutral static stability.

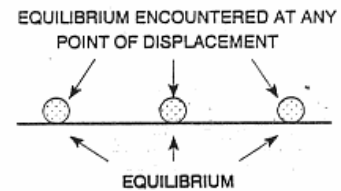

Figure 4-40 Neutral Static Stability

Dynamic Stability

Static stability reveals nothing about whether the object ever settles back to its original equilibrium position. To study dynamic stability, we will first assume the object to possess positive static stability.

Consider a ball at the top of Figure 4-38. After it is released, it will roll back to the bottom and up the other side. It will roll back and forth, and due to friction will oscillate less and less about the equilibrium position until it finally comes to rest at the bottom of the bowl. It possesses **positive dynamic stability**. Note that although the ball passes through the equilibrium position, it is not in equilibrium again until it has stopped moving. The motion described is **damped oscillation** (Figure 4-41).

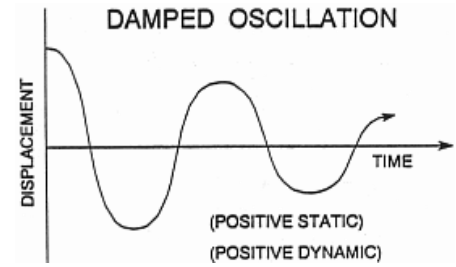

Figure 4-41 Positive Static and Positive Dynamic Stability

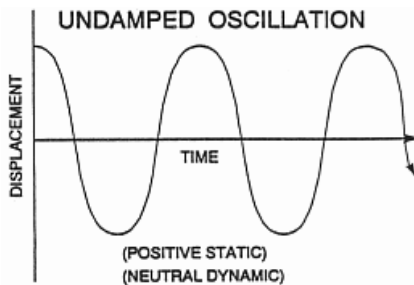

Figure 4-42 Positive Static and Neutral Dynamic Stability

If the ball oscillates about the equilibrium position and the oscillations never dampen out, in a frictionless environment, it possesses **neutral dynamic stability**. Figure 4-42 depicts its displacement relative to equilibrium over time. This motion is **undamped oscillation**.

If, somehow, the ball did not slow down, but continued to climb to a higher and higher position with each oscillation, it would never return to its original equilibrium position. Figure 4-43 depicts **negative dynamic stability**. This motion is impossible with a ball, but occasionally aircraft behave this way. This motion is **divergent oscillation**.

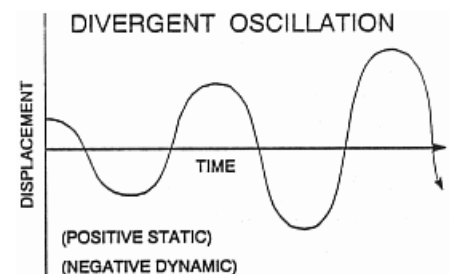

Figure 4-43 Positive Static and Negative Dynamic Stability

If an object does not have positive static stability, it cannot have positive dynamic stability. If an object has positive static stability, it can have any type of dynamic stability. In other words, static stability does not ensure dynamic stability, but static instability ensures dynamic instability. If an object is dynamically **stable**, the displacement from equilibrium will be reduced until the object is again at its original equilibrium. It must have both positive static and positive dynamic stability. If an object is dynamically **unstable**, the displacement may or may not increase, but the object will never return to its original equilibrium.

Airplane Static Stability And Maneuverability

Equilibrium occurs when the sum of the forces and moments around the center of gravity (CG) are equal to zero. An aircraft in equilibrium will travel in a constant direction at a constant speed, developing no moments that would cause it to rotate around the CG. Since an airplane can rotate around three different axes, we must consider its stability around each of these axes. **Longitudinal stability** is stability of the longitudinal axis around the lateral axis (pitch). **Lateral stability** is stability

of the lateral axis around the longitudinal axis (roll). **Directional stability** is stability of the longitudinal axis around the vertical axis (yaw). Each motion requires a separate discussion.

Any discussion of airplane stability requires an explanation on how the wings, fuselage, vertical stabilizer, horizontal stabilizer, etc, affect the longitudinal, lateral, and directional stability of the airplane. This lesson considers only conventional airplanes, that is, airplanes with their wings, fuselage and stabilizers in their normal positions.

We'll make some basic assumptions to simplify our study. First, we assume a constant TAS. The disturbances that cause the airplane to pitch, yaw, or roll will be small enough that it does not affect the airplane's forward velocity. The disturbances will also be small enough to keep the change in pitch attitude, and degree of yaw and roll small enough so that we do not approach any stalling AOA's or unusual attitudes. These disturbances are external and not caused by the pilot. The pilot applies no inputs to correct the displacement from equilibrium. Any moment that corrects the airplane's attitude results from the design of the airplane.

An airplane's **maneuverability** is the ease with which it will move out of its equilibrium position. Maneuverability and stability are opposites. A stable airplane tends to stay in equilibrium and is difficult for the pilot to move out of equilibrium. The more maneuverable an airplane is, the easier it departs from equilibrium, and the less likely it is to return to equilibrium.

There are two ways to increase an airplane's maneuverability. If we want an airplane to move quickly from its trimmed equilibrium attitude, we can give it weak stability. Of course, this means the airplane will be more difficult to fly in equilibrium and will require more of the pilot's attention. Our other option is to give the airplane larger control surfaces. If the control surfaces are large, they can generate large moments by producing greater aerodynamic forces. The airplane designer must decide how to compromise between stability and maneuverability. The mission of a specific airplane dictates the compromises the designer will have to make. A transport plane must be relatively stable for long range flights and ease in landing. A fighter must possess great maneuverability for high performance turning.

Now that we have a basic understanding of static stability, we can discuss each component and its individual contribution to static stability. Afterwards, we'll combine all the components and discuss the overall static stability of the airplane.

Longitudinal Static Stability

Longitudinal static stability is stability of the longitudinal axis around the lateral axis. An airplane has longitudinal stability if, after some disturbance causes it to pitch up or down, it generates forces and moments that tend to move the pitch attitude to a level flight condition.

The Flying Wing Model

Each individual component may have its own aerodynamic center, and thus its own effect on static stability. These individual components create moments around the CG of our airplane that can be either stabilizing or destabilizing. To examine stability in greater detail, we will first take a simplified approach using a "flying wing" model. By choosing the flying wing we have essentially eliminated the stability effect of any component except the wing itself. An airplane experiences four main forces in equilibrium flight: lift, weight, drag, and thrust. Recall that these forces act around the center of gravity. For our discussion of longitudinal stability we only need to address lift and weight. Figure 4-44 shows these two forces in equilibrium on our airplane.

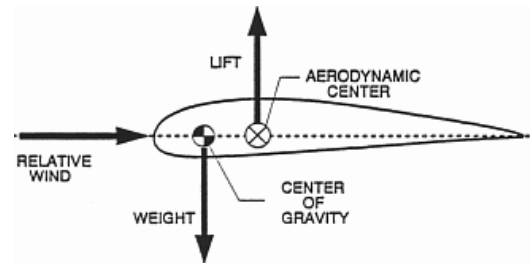

Figure 4-44 Flying Wing Model

Notice in Figure 4-44 that lift is acting through the aerodynamic center (AC), which is at a distance from our CG. This creates a moment around the CG. It should be understood that our flying wing in Figure 4-44 is in equilibrium, and that trim devices are preventing the wing from rotating to a nose-down attitude.

Consider how the flying wing reacts to a disturbance that increases the AOA sensed by the airfoil. The increased AOA will increase lift. If the CG is ahead of the AC, the increase in lift at the AC develops a moment that pitches the nose of the airplane down in the direction of its original equilibrium AOA. Our flying wing has positive longitudinal static stability because of its initial tendency to return to equilibrium (Figure 4-45). If a component's aerodynamic center is behind the airplane's center of gravity the component will be a positive contributor to longitudinal static stability.

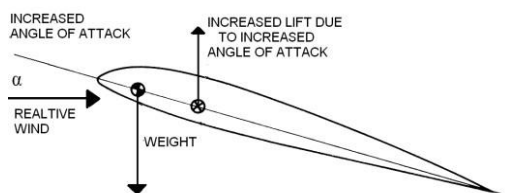

Figure 4-45 Positive Longitudinal Static Stability

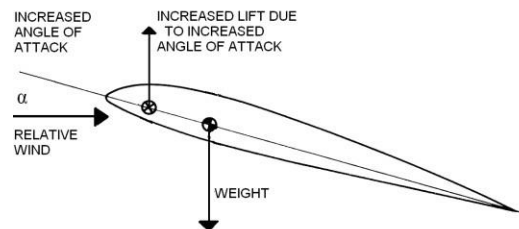

Figure 4-46 Negative Longitudinal Static Stability

Next, examine a flying wing where the AC is ahead of the CG. When the disturbance increases AOA, the wing produces more lift and rotates the flying wing further away from equilibrium (Figure 4-46). Any disturbance would soon lead to stall and possibly out of control flight. We can generalize this and

say that if a component's aerodynamic center is in front of the airplane's center of gravity the component will be a negative contributor to longitudinal static stability.

Straight Wings

The wing's contribution to longitudinal static stability depends mainly on the location of the wing's AC with respect to the airplane's CG. Most airplanes have straight wings with the AC forward of the airplane's CG. Like the second flying wing example, having the AC forward of the CG causes longitudinal static instability. The wings of most conventional airplanes are negative contributors to longitudinal static stability. Figure 4-47 illustrates the location of the wing's AC and the airplane's CG.

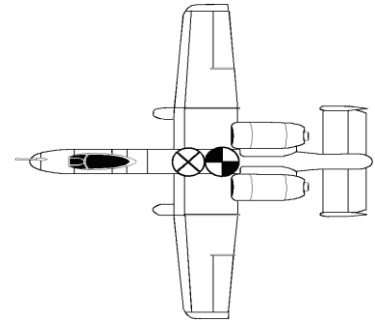

Figure 4-47 Straight Wings

Wing Sweep

AC moves aft as the wings sweep aft, stabilizing the aircraft longitudinally.

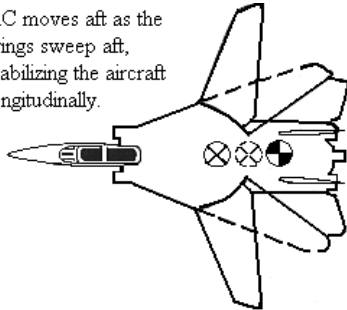

Figure 4-48 Wing Sweep

When an F-14's wings are swept forward, they have a strong longitudinally destabilizing effect. This is because the wing's AC is well forward of the airplane's CG. This increases the F-14's maneuverability. As sweep angle increases (i.e. the wings move aft), the wings' AC moves aft, closer to the airplane's CG (Figure 4-48), making the airplane more longitudinally stable. Sweeping an airplane's wings back is a positive contributor to longitudinal static stability.

The Fuselage

The fuselage acts as an airfoil and thus produces lift. The fuselage's AC is usually located ahead of the airplane's CG (Figure 4-49). If a disturbance causes an increase in angle of attack, the fuselage will produce greater lift that produces a destabilizing effect. The fuselage is a negative contributor to longitudinal static stability.

THE HORIZONTAL STABILIZER

The horizontal stabilizer is a symmetric airfoil designed to stabilize the airplane around the lateral axis. Its contribution to longitudinal static stability is determined by the moment it produces around the CG. Since its AC is well behind the airplane's CG (Figure 4-50), the horizontal stabilizer has the greatest positive effect on longitudinal static stability. The pitching moment can be increased by increasing the distance between the airplane's CG and the stabilizer's AC, or by enlarging the horizontal stabilizer. Thus, for a short moment arm between the airplane's CG and the horizontal stabilizer's aerodynamic center, a large horizontal stabilizer is needed. For an airplane with a longer moment arm, a smaller horizontal stabilizer will suffice.

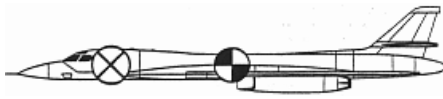

Figure 4-49 Fuselage

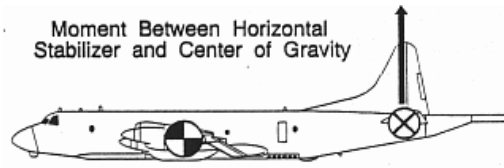

Figure 4-50 Horizontal Stabilizer

THE NEUTRAL POINT

The longitudinal static stability provided by the horizontal stabilizer must overcome the instabilities of the wings and fuselage in order to produce a stable airplane. Figure 4-51 shows the AC for each individual component. The **neutral point (NP)** is the location of the center of gravity along the longitudinal axis that would provide neutral longitudinal static stability. It can be thought of as the aerodynamic center for the entire airplane. The location of the NP is fixed on conventional airplanes, but we can change the location of the CG by moving around cargo or mounting ordnance and fuel in various locations. As the CG is moved aft, the airplane's static stability decreases. The NP defines the farthest aft CG position without negative stability. Once the CG is aft of the NP the airplane becomes unstable and the pilot may have difficulty controlling it in flight.

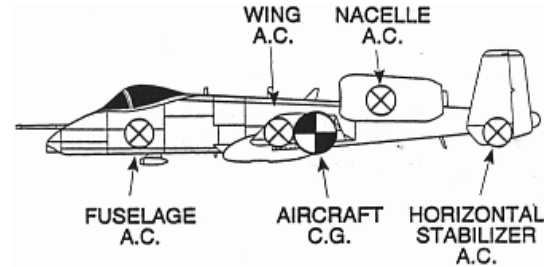

Figure 4-51 AC for each component

Directional Static Stability

Directional static stability is stability of the longitudinal axis around the vertical axis. When an airplane yaws, its momentum keeps it moving along its original flight path for a short time. This condition is known as a **sideslip**. The angle between the longitudinal axis and the relative wind is called the **sideslip angle (β)** (Figure 4-52). The component of the relative wind that is parallel to the lateral axis is called the **sideslip relative wind**. Reaction to the sideslip will determine a component's contribution to directional static stability. We will examine the effects of the wings, wing sweep, fuselage, and the vertical stabilizer on directional static stability.

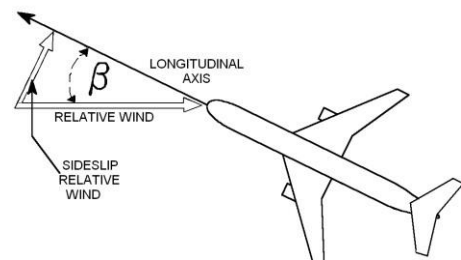

Figure 4-52 Sideslip Angle β

Straight Wings

During a sideslip, the advancing wing on a straight winged airplane has a momentary increase in airflow velocity as it moves forward. This increases parasite drag on that wing and pulls it back to its equilibrium position. The retreating wing has less velocity and less parasite drag, which helps to bring the nose back into the relative wind. Therefore, straight wings have a small positive effect on directional static stability.

SWEPT WINGS

The swept design of a wing will further increase directional stability. The advancing wing not only experiences an increase in parasite drag, but also an increase in induced drag due to the increased chordwise flow. Remember that lift and induced drag are produced by the wings when air flows chordwise over them. The retreating wing experiences more spanwise flow. Figure 4-53 depicts this phenomenon with the left wing experiencing greater induced and parasite drag. The result is an airplane that comes back into the relative wind.

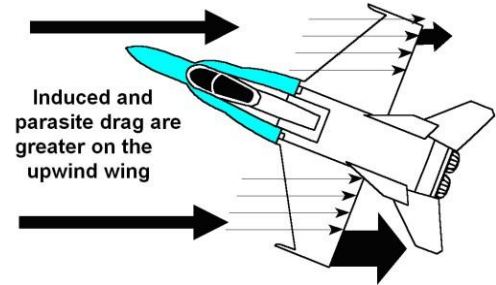

Figure 4-53 Swept Wings

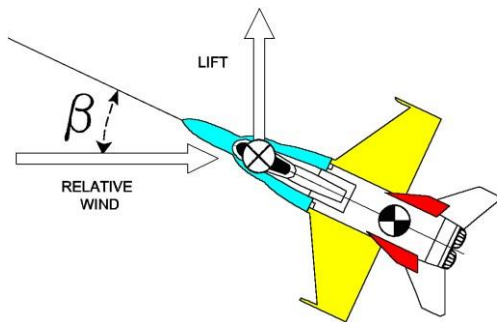

Figure 4-54 Fuselage

THE FUSELAGE

The fuselage is a symmetric airfoil with its aerodynamic center forward of the airplane's CG. At zero angle of attack or zero sideslip it produces no net lift. When the airplane enters a sideslip, an angle of attack is created on the fuselage. The lift produced at the fuselage AC pulls the nose away from the relative wind, thus causing an increase in the sideslip angle. Therefore, the fuselage is a negative contributor to the airplane's directional static stability (Figure 4-54).

The Vertical Stabilizer

The vertical stabilizer is the greatest positive contributor to the directional static stability of a conventionally designed airplane. The vertical stabilizer is a symmetric airfoil mounted far behind the airplane's CG. A sideslip causes the vertical stabilizer to experience an increased angle of attack. This creates a horizontal lifting force on the stabilizer that is multiplied by the moment arm distance to the airplane's CG (Figure 4-55). The moment created will swing the nose of the airplane back into the relative wind. This is identical to the way a weather-vane stays oriented into the wind. There is an inverse relationship between tail size and moment arm length. The smaller the distance to the CG, the larger the vertical stabilizer must be and vice versa. It is not always desirable to have a large vertical stabilizer because of limited storage room aboard aircraft carriers and the large radar signatures. Designers often use two or more smaller vertical stabilizers (A-10, F-15, F/A-18, and E-2), to accomplish the same stability effects as one large stabilizer.

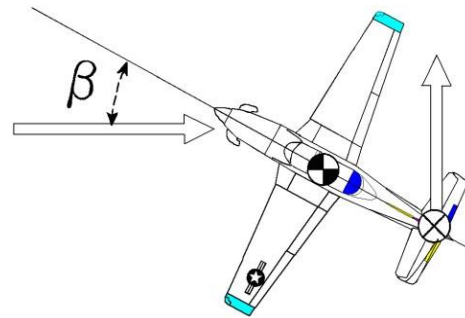

Figure 4-55 Vertical Stabilizer

Lateral Static Stability

Lateral stability is stability of the lateral axis around the longitudinal axis. An airplane has lateral stability if, after some disturbance causes it to roll, it generates forces and moments that tend to reduce the bank angle and restore the airplane to a wings level flight condition. When an airplane rolls, the lift vector points to the inside of the turn, reducing the vertical component of lift. Since weight still acts downward with the same force (Figure 4-56), the plane descends. The horizontal component of lift pulls the airplane to the side, thus creating a sideslip relative wind. This sideslip relative wind acts on the various components of the airplane causing stability or instability.

DIHEDRAL EFFECT

When an airplane is laterally sideslipping, dihedral wings cause an increase in angle of attack and lift on the down-going wing. The up-going wing has a reduced angle of attack and a decrease in lift (Figure 4-57). This difference in lift creates a rolling moment that rights the airplane and stops the sideslip. Wings that are straight have neutral lateral static stability. Dihedral wings are the greatest positive contributors to lateral static stability. Anhedral wings are the greatest negative contributors to lateral static stability.

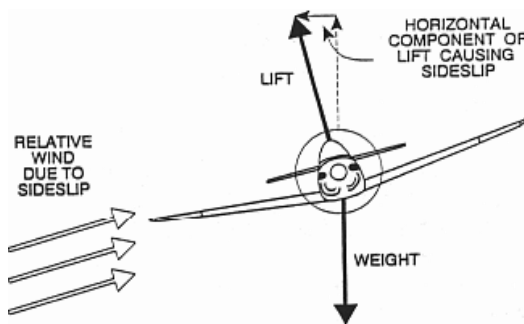

Figure 4-56 Sideslip Relative Wind

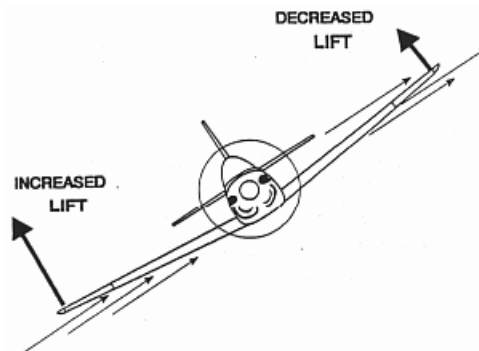

Figure 4-57 Dihedral Wings

WING PLACEMENT ON THE VERTICAL AXIS

During a sideslip the fuselage of a high-winged airplane impedes the airflow generated by the sideslip. This increases the upwash at the wing root on the down-going wing which increases the AOA and lift. The up-going wing receives downwash which decreases the AOA, and lift. The lift imbalance rolls the airplane back to wings level. A low-mounted wing has the opposite effect. Thus, a high mounted wing is a positive contributor, and a low mounted wing is a negative contributor to lateral static stability (Figure 4-58).

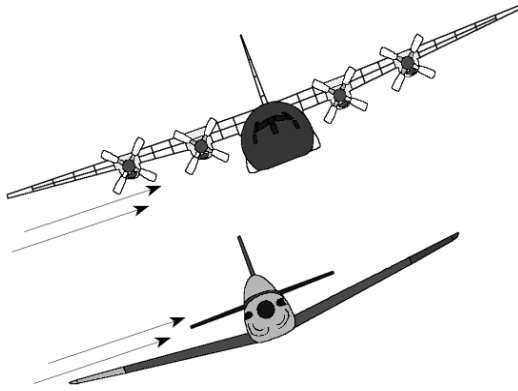

Figure 4-58 High- and Low-Mounted Wings

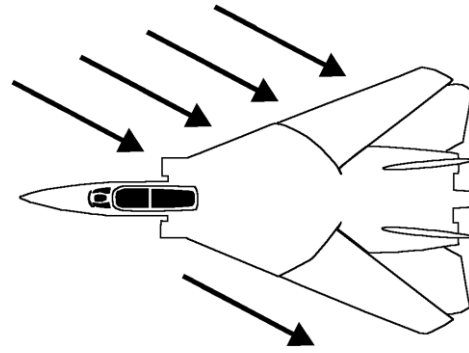

Figure 4-59 Wing Sweep

WING SWEEP

Another way to affect lateral stability is to sweep the wings aft. As an airplane begins to sideslip in the direction of roll, the wing toward the sideslip has more chordwise flow than the wing away from the sideslip (Figure 4-59). The wing toward the sideslip (the lower wing) generates more lift, which levels the wings. Swept wings are laterally stabilizing. These effects are cumulative. High-mounted, swept dihedral wings are much more stable than low-mounted, straight wings with the same dihedral.

The Vertical Stabilizer

The only other major effect on lateral stability comes from the vertical stabilizer. When in a lateral sideslip, the vertical stabilizer senses an angle of attack, so it produces lift. Since the tail is above the airplane's center of gravity, this lift produces a moment that tends to right the airplane (Figure 4-60).

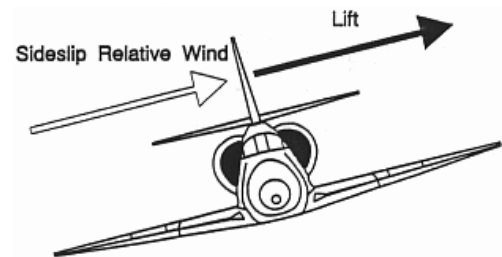

Figure 4-60 Vertical Stabilizer

Dynamic Stability

Our discussion thus far has centered on static stability. When we discuss dynamic stability, we must realize that lateral and directional stability are interrelated. This interrelationship is called cross-coupling. The motions of an airplane are such that a rolling motion causes a yawing motion and vice versa. This cross-coupling between directional static stability and lateral static stability causes several dynamic effects including spiral divergence, Dutch roll, proverse roll, and adverse yaw.

Directional Divergence

Directional divergence is a condition of flight in which the reaction to a small initial sideslip results in an increase in sideslip angle (Figure 4-61). Directional divergence is caused by negative directional static stability. If the vertical stabilizer becomes ineffective for some reason (battle damage, mid-air collision), directional divergence could cause out of control flight. Most airplanes have very strong directional stability to prevent this from occurring.

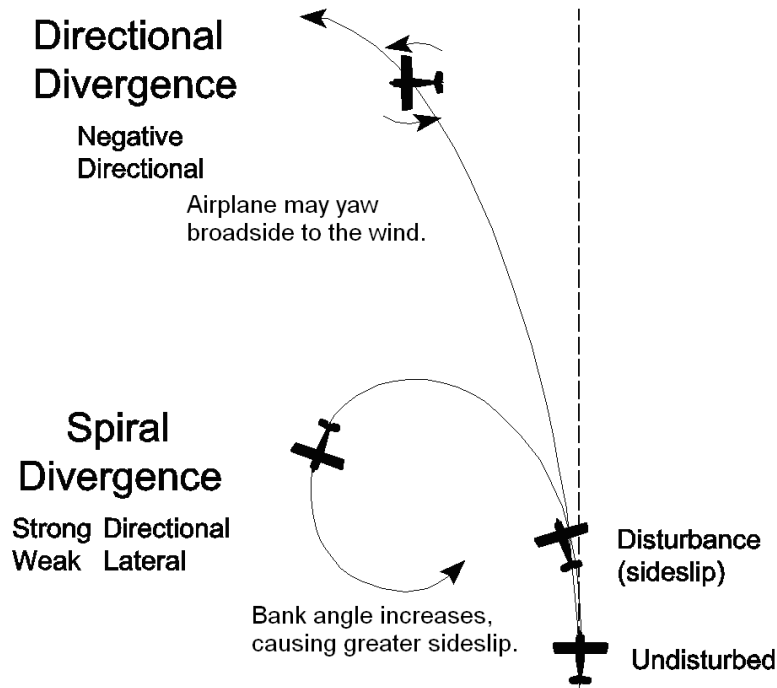

Figure 4-61 Directional and Spiral Divergence

SPIRAL DIVERGENCE

Spiral divergence occurs when an airplane has strong directional stability and weak lateral stability (Figure 4-61). For example, an airplane is disturbed so that its wing dips and starts to roll to the left. Because the airplane has weak lateral stability it cannot correct itself and the flight path arcs to the left. The airplane senses a new relative wind from the left and aligns itself with the new wind by yawing into it (strong directional stability). The right wing is now advancing and the increased airflow causes the airplane to roll even more to the left. The airplane will continue to chase the relative wind and will develop a tight descending spiral. This is easily corrected by control input from the pilot.

DUTCH ROLL

Dutch roll is the result of strong lateral stability and weak directional stability. The airplane responds to a disturbance with both roll and yaw motions that affect each other. For example, a gust causes the airplane to roll left, producing a left sideslip. The strong lateral stability increases lift on the left wing and corrects it back to wings level. At the same time, the nose of the airplane yaws left into the sideslip relative wind. This leaves the airplane wings level, with the nose cocked out to the left.

The weak directional stability now swings the nose to the right to correct the nose back into the relative wind. This causes the left wing to advance faster than the right wing, a situation which produces more lift on the left wing and rolls the airplane to the right, creating a right sideslip. The strong lateral stability corrects the wings back to level, while the nose yaws right into the sideslip relative wind. This leaves the airplane wings level, with the nose cocked out to the right. As the nose yaws left into the relative wind, the wings will roll left which starts the entire process again.

The airplane appears to be “tail wagging” (Figure 4-62). This condition can be tolerated and may eventually dampen out. However, it is not acceptable in a fighter or attack airplane when the pilot is trying to aim at a target.

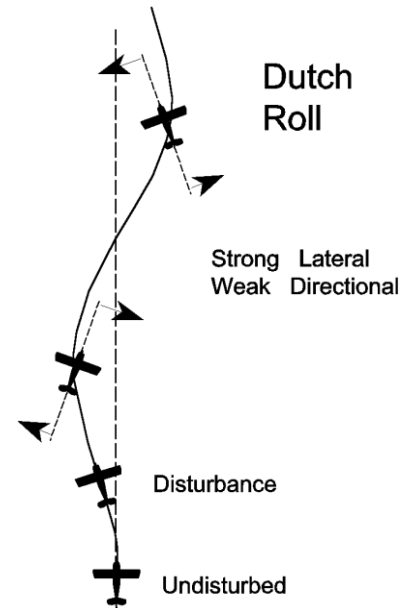

Figure 4-62 Dutch Roll

Phugoid Oscillations

Phugoid oscillations are long period oscillations (20 to 100 seconds) of altitude and airspeed while maintaining a nearly constant angle of attack. Oscillations of pitch attitude do occur, but are often minor. Phugoid oscillations are not a result of cross-coupling. Upon being struck by an upward gust, an airplane would gain altitude and lose airspeed. A large but gradual change in altitude and airspeed occurs. When enough airspeed is lost, the airplane will nose-over slightly, commencing a gradual descent, gaining airspeed and losing altitude. When enough airspeed is regained, the nose will pitch up, starting the process over. The period of this oscillation is long enough that the pilot can easily correct it. Often, due to the almost negligible changes in pitch, the pilot may make the necessary corrections while being completely unaware of the oscillation.

Pilot / Airplane Interaction

A complete discussion of an airplane’s stability characteristics is not limited to how the airplane reacts to various external forces, but must also consider the interaction of the pilot and the airplane.

Proverse Roll

Proverse roll is the tendency of an airplane to roll in the same direction as it is yawing. When an airplane yaws, the yawing motion causes one wing to advance and the other wing to retreat. This increases the airflow on the advancing wing and decreases airflow over the retreating wing. A difference in lift is created between the two wings, and the airplane rolls in the same direction as it

yawed. Proverse roll is even more pronounced on swept wing airplanes since the advancing wing will have more chordwise flow and will produce more lift.

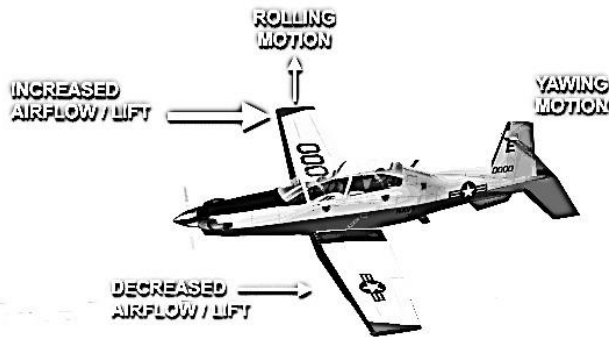

Figure 4-63 Proverse Roll

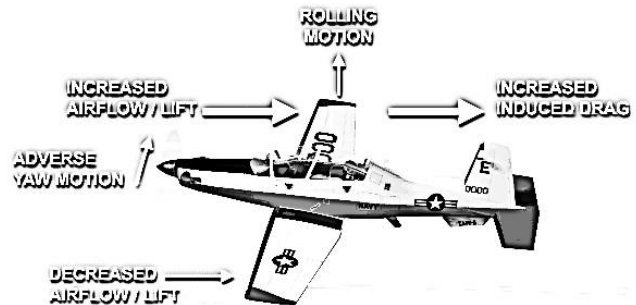

Figure 4-64 Adverse Yaw

Adverse Yaw

Adverse yaw is the tendency of an airplane to yaw away from the direction of aileron roll input. When an airplane rolls, it has more lift on the up-going wing than on the down-going wing. This causes an increase in induced drag on the up-going wing that will retard that wing's forward motion and cause the nose to yaw in the opposite direction of the roll. The aircraft produces adverse yaw each time the ailerons are deflected (rolling into and out of a turn).

We can do three things to overcome this problem. The first method is to use spoilers instead of ailerons. The spoiler is deflected into the airstream from the upper surface of the wing. This spoils the airflow and reduces lift, causing the airplane to roll. The spoiler increases the parasite drag on the down-going wing, offsetting the induced drag on the up-going wing and helps reduce or eliminate adverse yaw. The second method is to use a rudder input to offset adverse yaw. The third is actually a design method of building the aircraft with differential ailerons.

PILOT INDUCED OSCILLATIONS

Pilot induced oscillations (PIO) are short period oscillations of pitch attitude and angle of attack. PIO or porpoising occurs when a pilot is trying to control airplane oscillations that happen over approximately the same time span as it takes to react. For example, a gust of wind causes the nose to pitch up. The natural longitudinal stability of the airplane will normally compensate. However, if the pilot tries to push the nose-down, his input may coincide with the stability correction, causing the nose to over correct and end up low. The pilot then pulls back on the stick causing the nose to be high again. Since the short period motion of PIO is of relatively high frequency, the amplitude of the pitching could reach dangerous levels in a very short time. If PIO is encountered, the pilot must rely

on the inherent stability of the airplane and immediately release the controls, if altitude permits. If not, the pilot should “freeze” the stick slightly aft of neutral.

ASYMMETRIC THRUST

Any airplane with more than one engine can have directional control problems if one engine fails. This is known as asymmetric thrust. If an airplane with its engines located far from the fuselage, such as an S-3, E-2 or KC-10, has an engine failure, the thrust from the operating engine(s) will create a yawing moment toward the dead engine (Figure 4-65). This can happen even if the engines are relatively close, such as with the F/A-18. The farther from the longitudinal axis that the engines are located the greater the moment created by the operating engine. The yawing motion may be sufficient to cause proverse roll. Full opposite rudder may be required to compensate for the yawing moment, while opposite aileron should be used to correct the proverse roll. Every multi-engine airplane has a minimum directional control speed that must be flown to ensure maximum effectiveness of the vertical stabilizer following an engine failure.

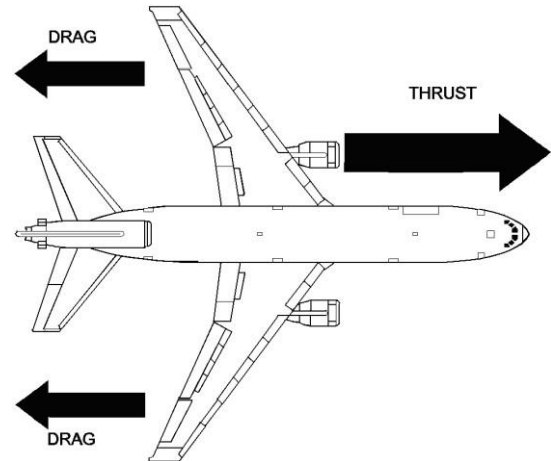

Figure 4-65 Asymmetric Thrust

ASSIGNMENT SHEET 2-4-3

PERFORMANCE & MANEUVERING REVIEW

A. INTRODUCTION

Performance and Maneuvering is the third aerodynamics lesson in a series presenting aerodynamic theories and operational principles. Upon completion of this lesson, you will understand aircraft performance with respect to temperature, maximum range and endurance, and aircraft speeds relating to the lift and thrust curves. You will also understand maneuvering characteristics relating to velocity, angle of attack, load factor, and aircraft stability.

B. ENABLING OBJECTIVES

C. STUDY ASSIGNMENT

1. Review Naval Aviation Fundamentals, NAVAVSCOLSCOM-SG-200 Unit 2, Chapter 3
2. Read Naval Aviation Fundamentals, NAVAVSCOLSCOM-SG-200 Unit 2, Chapter 4

D. STUDY QUESTIONS

1. Takeoff distance is _____.
 - a. decreased by a tailwind
 - b. increased by a tailwind
 - c. decreased by higher elevation
 - d. increased by use of flaps
2. Max range is defined as _____.
 - a. the farthest distance an airplane can travel with a headwind component of 50 knots or less
 - b. the farthest distance an airplane is allowed to travel
 - c. the most time an airplane can remain airborne for a given amount of fuel
 - d. the farthest distance an airplane can travel on a given amount of fuel
3. Max endurance is _____.
 - a. the farthest distance an airplane can travel on a given amount of fuel
 - b. the maximum time that an airplane can remain airborne on a given amount of fuel
 - c. the most amount of time an airplane can spend at cruise altitude
 - d. not affected by configuration

4. Max glide range (flown at Best Glide Speed) is _____.
 - a. obtained by flying at L/D_{MAX} airspeed
 - b. decreased by a tailwind
 - c. not affected by altitude
 - d. flown at an airspeed less than L/D_{MAX} airspeed

5. Gaining the most altitude in a given amount of time is _____.
 - a. based on amount of excess thrust available
 - b. used for obstacle clearance
 - c. Max Angle of Climb
 - d. Max Rate of Climb

6. Slipstream swirl is most noticeable _____.
 - a. at low power settings and high airspeed
 - b. at high power settings and low airspeed
 - c. in a spin
 - d. when the aircraft displays positive directional stability

7. Ultimate load factor for the T-6B is defined as _____.
 - a. the least load factor an airplane can sustain without any risk of permanent deformation
 - b. +6.0 Gs
 - c. -1.0 G
 - d. the maximum load factor that the airplane can withstand without structural failure

8. Turn radius is _____.
 - a. a factor of velocity and bank angle
 - b. a factor of weight, airspeed, and temperature
 - c. a factor of velocity, wingspan, and bank angle
 - d. measured in degrees per second

9. Critical Mach is defined as _____.
 - a. the ratio of true airspeed to the local speed of sound
 - b. the speed at which the airplane goes supersonic
 - c. the Mach number that produces the first evidence of local supersonic flow
 - d. aircraft's maximum allowable Mach number

10. Sideslip angle is _____.
 - a. the angle between the relative wind and the lateral axis
 - b. the difference between the flightpath and the longitudinal axis
 - c. greater in aircraft that have positive static stability
 - d. smaller in fighter/attack aircraft

11. When flying at maximum endurance airspeed in the T-6B, increasing AOA to maintain level flight will result in _____.
- a. higher airspeed requiring less power
 - b. higher airspeed requiring more power
 - c. slower airspeed requiring less power
 - d. slower airspeed requiring more power

ADDITIONAL LESSON REVIEW QUESTIONS

1. Of the factors affecting takeoff and landing performance, what is the single largest contributor to increasing takeoff or landing distance?
2. Why is it impossible to exceed the aircraft load limit at airspeeds below cornering velocity?
3. What is the difference between positive and negative static stability?
4. Which airframe component is the largest positive contributor to aircraft directional static stability?

Increased Factor	Air Density	Takeoff Roll
Weight	N/C	↑
Altitude	↓	↑
Temperature	↓	↑
Humidity	↓	↑
Headwind	N/C	↓
Tailwind	N/C	↑

Figure 1 – Takeoff Factors Summary Chart

Increased Factor	ROC	AOC
Weight	↓	↓
Configuration	↓	↓
Altitude	↓	↓
Temperature	↓	↓
Humidity	↓	↓
Headwind	N/C	↑
Tailwind	N/C	↓

Figure 2 – Climb Factors Summary Chart

Increased Factor	Maximum Endurance	Maximum Range
Weight	↓	↓
Configuration	↓	↓
Altitude	↑	↑
Temperature	↓	↓
Headwind	N/C	↓
Tailwind	N/C	↑

Figure 3 – Cruise Factors Summary Chart

Increased	Turn Radius	Turn Rate
Airspeed	↑	↓
Bank Angle	↓	↑

Figure 4 – Turn Performance Summary Chart

Increased Factor	Air Density	Landing Distance
Weight	N/C	↑
Altitude	↓	↑
Temperature	↓	↑
Humidity	↓	↑
Headwind	N/C	↓
Tailwind	N/C	↑

Figure 5 – Landing Factors Summary Chart

Answers:

- 1.B 7. D
- 2.D 8. A
- 3.B 9. C
- 4.A 10. B
- 5.D 11. D
- 6.B

Answers to Additional Lesson Review Questions:

1. Weight is the greatest factor. Doubling weight quadruples both takeoff and landing distance.
2. Cornering velocity is the minimum airspeed at which the aircraft G-load limit can be obtained. Below this airspeed the aircraft will stall, making an over-G condition impossible.
3. a. Positive static stability: Initial tendency is for the object to return to its original equilibrium position
b. Negative static stability: Initial tendency is for the object to move away from its original equilibrium position.
4. The vertical stabilizer is the greatest positive contributor to directional static stability due to its weathervane effect.

OUTLINE SHEET 2-5-1

SPINS

A. INTRODUCTION

This lesson covers fundamental information on the aerodynamic causes and characteristics of aircraft spins. At the completion of this lesson, you will be able to define and state the causes of a spin and describe the aerodynamic factors affecting spin development.

B. ENABLING OBJECTIVES

- 3.19 DEFINE a spin, in a classroom, in accordance with Naval Aviation Fundamentals, NAVAVSCOLSCOM-SG-200
- 3.20 DEFINE autorotation, in a classroom, in accordance with Naval Aviation Fundamentals, NAVAVSCOLSCOM-SG-200
- 3.21 DESCRIBE the aerodynamic forces affecting a spin, in a classroom, in accordance with Naval Aviation Fundamentals, NAVAVSCOLSCOM-SG-200
- 3.22 STATE the characteristics of erect, inverted, and flat spins, in a classroom, in accordance with Naval Aviation Fundamentals, NAVAVSCOLSCOM-SG-200
- 3.23 DESCRIBE the factors contributing to aircraft spin, in a classroom, in accordance with Naval Aviation Fundamentals, NAVAVSCOLSCOM-SG-200
- 3.24 DISCUSS the effects of weight, pitch attitude, and gyroscopic effects on spin characteristics, in a classroom, in accordance with Naval Aviation Fundamentals, NAVAVSCOLSCOM-SG-200
- 3.25 STATE how empennage design features change spin characteristics, in a classroom, in accordance with Naval Aviation Fundamentals, NAVAVSCOLSCOM-SG-200
- 3.26 STATE the cockpit indications of an erect and inverted spin, in a classroom, in accordance with Naval Aviation Fundamentals, NAVAVSCOLSCOM-SG-200
- 3.27 DESCRIBE the pilot actions necessary to recover from a spin, in a classroom, in accordance with Naval Aviation Fundamentals, NAVAVSCOLSCOM-SG-200
- 3.28 DESCRIBE a progressive spin, in a classroom, in accordance with Naval Aviation Fundamentals, NAVAVSCOLSCOM-SG-200

3.29 DESCRIBE an aggravated spin, in a classroom, in accordance with Naval Aviation Fundamentals, NAVAVSCOLSCOM-SG-200

C. TOPIC OUTLINE

1. Introduction
2. This Lesson Topic
3. Spin Development
4. Spin Aerodynamics
5. Spin Indications and Recovery
6. Summary and Review
7. Application
8. Assignment

INFORMATION SHEET 2-5-2

SPINS

A. INTRODUCTION

This lesson covers fundamental information on the aerodynamic causes and characteristics of aircraft spins. At the completion of this lesson, you will be able to define and state the causes of a spin and describe the aerodynamic factors affecting spin development.

B. REFERENCES

1. Aerodynamics for Naval Aviators, NAVAIR 00-80T-80
2. T-6 Joint Primary Pilot Training, AETC / CNATRA Syllabus P-V4A-J NATOPS Flight Manual

C. INFORMATION

Spin Aerodynamics

A **spin** is an aggravated stall that results in autorotation. **Autorotation** is a combination of roll and yaw that propagates itself due to asymmetrically stalled wings. For an aircraft to spin two conditions are required: the aircraft must be stalled, and yaw must be present. Without both conditions present, an aircraft will not enter a spin. Yaw can be introduced intentionally, such as during training, or unintentionally. Unintentional yaw inputs can be pilot induced, such as misapplication of controls, or non-pilot induced, such as fuel loading, or wake turbulence.

To help you understand the aerodynamics of the spin, consider the motions an aircraft undergoes during a spin. Every aircraft exhibits different spin characteristics, but they all have stall and yaw about the spin axis. The **spin axis** is the aerodynamic axis around which stall and yaw forces act to sustain spin rotation. For the T-6B, the spin axis is a vertical axis through the cockpit, forward of the center of gravity. There are four phases to a spin: post-stall gyration, incipient, developed, and recovery phases.

The **poststall gyration phase** begins at the instant the airplane stalls, and is where the pilot provides the necessary elements for the spin, either unintentionally or intentionally. Poststall gyrations are determined by the aerodynamic forces during a stall that result in movement around the pitch, roll, and yaw axes. Poststall gyrations characteristics are dependent on airspeed. The higher the airspeed at stall entry, the greater poststall gyration severity, while the lower the airspeed at stall entry, the less poststall gyration severity. During a stall, lift and drag of both wings are balanced unless yaw is introduced. The introduction of yaw creates an AOA difference between the left and right wings. Poststall gyrations can result in introduction of yaw and can result in spin entry.

Examine the AOA and relative wind on each wing (Figure 5-1). In this example, the airplane stalls and begins a roll to the left. The left wing now becomes the down-going wing and senses a roll relative wind from beneath. This roll relative wind is added to the existing relative wind and creates an average relative wind that is further from the chord line; therefore, the down-going wing has a higher AOA. This wing has become more stalled. Conversely, the right wing becomes the up-going wing and senses a roll relative wind from above. When added to the original relative wind, the up-going wing has a lower AOA and is less stalled. Remember that while both wings are stalled, they do not lose all their lift, nor are they equally stalled.



Figure 5-1 Roll Relative Wind

The AOA differential results in two cases: lower AOA, more lift and less drag on the up-going wing, and higher AOA, less lift and more drag on the down-going wing (Figure 5-2).

The higher AOA on the down-going wing decreases the C_L generated by that wing. The up-going wing has a greater C_L due to a lower AOA, and therefore has greater total lift. The lift differential results in a continued rolling motion of the airplane around the spin axis.

The increased AOA on the down-going wing increases the C_D generated by that wing. The greater drag on the down-going wing results in a drag differential and causes a yawing motion around the spin axis. The combined effects of roll and yaw cause the airplane to continue its autorotation.

After the plane is stalled and poststall gyrations have introduced yaw, the incipient stage begins. The **incipient stage** begins after the poststall gyrations and ends when the spin is fully developed. This can take up to two rotations in most airplanes.

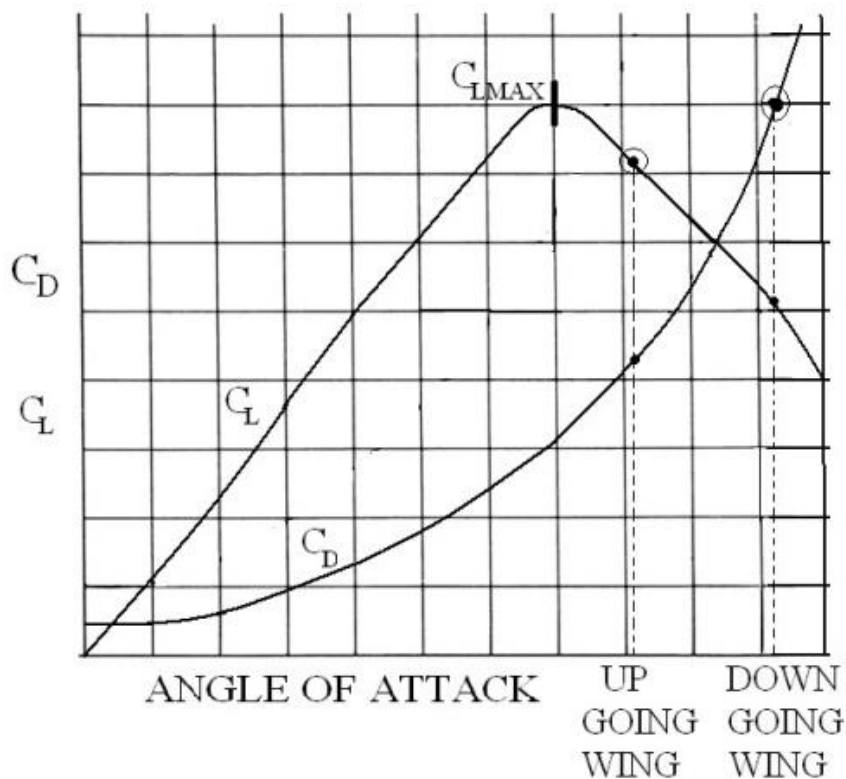

Figure 5-2 C_L and C_D in a Spin

Factors Affecting Spins

Conservation of angular momentum plays a significant role in determining how an airplane will spin. In the T-6B, the spin axis will be forward of the center of gravity. As the nose of the aircraft pitches down, the moment arm between the spin axis and the center of gravity shortens. This results in more mass closer to the moment of inertia and increases the rotation rate. An example of this is a spinning ice skater bringing their arms closer to their body and increasing their rate of rotation. Conversely, as the nose of the aircraft pitches up, the moment arm between the spin axis and the center of gravity increases, resulting in a more mass away from the moment of inertia and therefore, a slower rotation rate. Continuing the example from above, the ice skater is now moving their arms away from their body and slowing their rotation. Pitch attitudes can be affected by control inputs, aircraft weight, pitch attitude at stall entry, and spin direction

Ailerons

Depending on wing shape and the aerodynamic properties of a wing, ailerons applied in the direction of spin will cause increased roll and yaw oscillations, while ailerons applied in the direction opposite of spin rotation will tend to dampen roll and yaw oscillations. However, ailerons are not used to recover from a spin in the T-6B since they rarely assist in the recovery. This is a result of the wing being in a deep stall and little useful air flowing over the ailerons. Therefore, during a spin, apply neutral ailerons.

Rudder

The rudder is the principal control for stopping autorotation in the T-6B. During normal operation a rudder increases the angle of attack on the vertical stabilizer and produces lift, in the horizontal direction, that creates a yawing moment about the center of gravity. Due to the direction of the relative wind in a spin, the vertical stabilizer acts as a flat plate, instead of as an airfoil (Figure 5-3) and the rudder is used to create drag, not lift, to create the yawing moment. The direction of the rudder has a significant effect on the amount of drag created.

If the rudder is deflected in the same direction as the spin (pro-spin rudder), the amount of rudder exposed to the relative wind will be minimized and result in less drag. A rudder deflected in the opposite direction as the spin (anti-spin rudder), will maximize the amount of rudder exposed to the relative wind, and the amount of drag. The drag created by the vertical stabilizer can be divided into a horizontal and vertical component. The horizontal component creates a force that opposes the yawing of the airplane slowing rotation rate. The vertical component creates a force that pulls the tail up and pitches the nose-down, reducing the AOA on both wings.

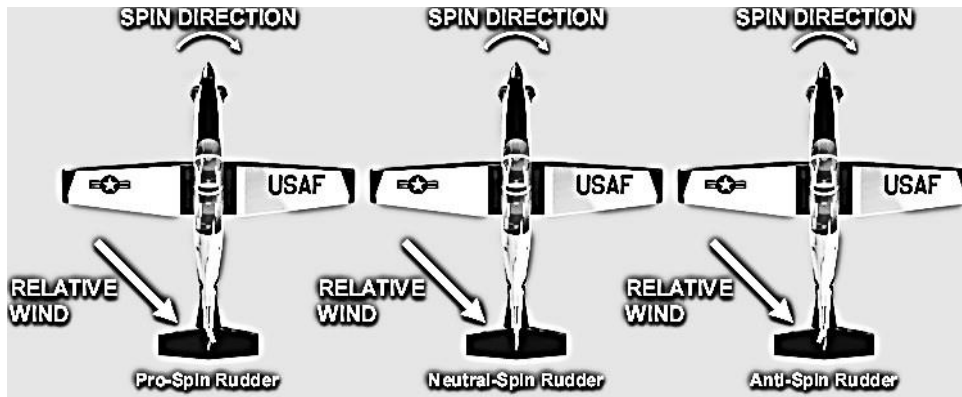
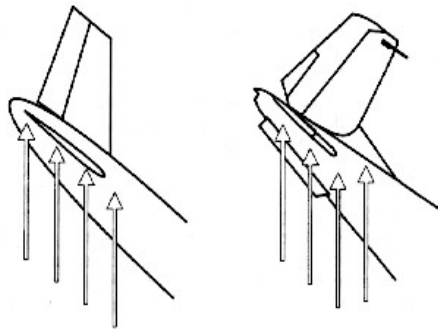

Figure 5-3 Rudder Forces During a Spin

The design of the vertical stabilizer and rudder and the placement of the horizontal control surfaces will significantly affect spin recovery. In the case of a swept vertical fin (Figure 5-4), airflow to the rudder is almost entirely blocked by the horizontal surfaces and is therefore not effective at stopping the autorotation. With the T-6B tail design, airflow to the rudder is not blocked and the horizontal stabilizer is farther aft, exposing more of the rudder in a spin increasing spin-recovery characteristics.

It is interesting that although an inverted spin in a T-6B is difficult to enter and very disorienting, it is easy to recover from. This is due to the entire vertical stabilizer is in an inverted position and therefore completely exposed to the relative wind

The T-6B uses a dorsal fin, strakes, and ventral fin to decrease the severity of spin characteristics (Figure 5-5). The dorsal fin is attached to the front of the vertical stabilizer to increase its surface area. This decreases the spin rate and aids in stopping the autorotation. A ventral fin on the T-6B is located beneath the empennage. Ventral fins decrease the spin rate and aid in maintaining a nose down attitude. The T-6B has strakes located in front of the horizontal stabilizer. These strakes increase the surface area of the horizontal stabilizer in order to keep the nose pitched down and prevent a flat spin.



SWEPT VERTICAL FIN
Figure 5-4 Effect of a Swept Vertical Fin

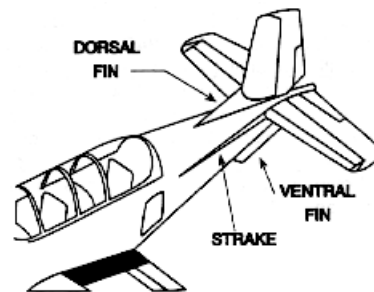

Figure 5-5 Empennage

Elevator

In a stabilized spin, the horizontal stabilizer and elevator are fully stalled due to an angle of attack in excess of 50° . This results in very little lift and a great amount of drag. The drag will be maximized with full down elevator and minimized with full up elevator (Figure 5-6). The increased drag on the horizontal stabilizer and elevator will cause a more nose-down pitch attitude. Similar to the vertical stabilizer, this drag will also have a vertical and horizontal component.



Figure 5-6 Effect of Elevator

Full aft stick results in the flattest pitch attitude and therefore the slowest spin rate. This is referred to as an unaccelerated spin. Any stick position other than full aft will result in a steeper pitch attitude and an increase in rotation rate. This is referred to as an accelerated spin.

As the pitch attitude is slowly lowered, the increase in spin rate causes the center of gravity to experience a greater force away from the spin axis. The acceleration resists the airplane moving to a steeper pitch attitude. This is why brisk control inputs are emphasized in a recovery. Abrupt forward stick will drive the pitch attitude down before rotation rate can increase appreciably and build up the nose down resistance.

Aircraft Weight

The aircraft's weight varies primarily due to fuel usage, but can also vary if items are dropped off the airplane (e.g., ordnance, fuel tanks, etc.). If an aircraft carries fuel in the wings, a large portion of the weight of the airplane is away from the center of gravity. This creates a large moment of inertia for a spin to overcome. A heavier airplane will have a slower spin entry with lesser oscillations due to this large moment of inertia. A lighter airplane will enter a spin more quickly, with greater oscillations possible, but will also recover from a spin faster.

Pitch Attitude

The pitch attitude will have a direct impact on the speed the aircraft stalls. For a given power setting, stall speed varies inversely with pitch attitude. As an airplane increase its pitch attitude, a larger portion of the thrust vector is in the vertical, in effect, adding lift. This additional lift reduces the load seen by the wings allowing for a slower stall speed. Slower stall speeds make the spin entry slower and with lesser oscillations. At lower pitch attitudes, the aircraft stalls at a higher airspeed and entries are faster and more oscillatory.

Spin Direction

Gyroscopic precession is a phenomenon that occurs when a gyroscope experiences a force. A gyroscopic mass reacts to a disturbance (force) along the rotational axis at a point 90° further in the rotation cycle. The propeller of the T-6B is a clockwise rotating gyroscope (as viewed from cockpit). If an airplane is in a right spin (nose yawing right), the nose of the T-6B will tend to pitch down due to gyroscopic precession. Conversely, if the T-6B is in a left spin, the nose will tend to pitch up. The T-6B will therefore have a flatter attitude when spinning to the left than to the right. This makes for a

more nose-high pitch attitude, slower rotation rate and smoother entries into spins that stabilize quicker. A T-6B in a right spin will have a more nose down pitch attitude, higher rotation rate, and a more oscillatory entry.

Spin Indications

After the incipient stage, a spin is considered to be in the **developed phase**. The developed phase occurs when the airplane’s angular rotation rate, airspeed, and vertical speed are stabilized while in a flight path that is nearly vertical. This is where airplane aerodynamic forces and inertial forces are in balance, and the attitude, angles, and self-sustaining motions about the vertical axis are constant or repetitive.

The T-6B will spin either erect (upright) or inverted. Erect spins result from positive-G stall entries. Inverted spins occur from a negative-g stall. The type of spin is independent of aircraft attitude at entry.

In case of spatial disorientation during a spin, the pilot must be aware of what the cockpit instrument indications are for each type of spin. The instruments used to confirm a spin are the turn needle, AOA indicator, and airspeed indicator. The turn needle is the only reliable indicator of spin direction. The balance ball (slip indicator) gives no useful indication of spin direction and should be disregarded. The altimeter is monitored to ensure compliance with bailout/ejection criteria.

<u>Gauge</u>	<u>Spin Indications</u>	<u>Remarks</u>
Altimeter	Rapidly decreasing	May indicate up to 1000 feet above actual altitude.
AOA	18+ Units (pegged)	Stalled
Airspeed	120-135 KIAS	Stable
Turn Needle	Pegged in direction of spin	Spin rate: 100–170° per sec.
VSI	6000 fpm (pegged)	8,000–15,000 fpm
Attitude Gyro	May be tumbling	60° Nose down

Table 5-1 T-6B Indications of an Erect Spin
(characterized by nose-down, upright attitude, and positive Gs)

An inverted spin is characterized by an inverted attitude and negative Gs on the airplane. Stabilized inverted spins are uncommon because the positioning of the vertical stabilizer in this spin causes the airplane to recover easily. Inverted spins are very disorienting to the aircrew and difficult to enter. The T-6B is prohibited from performing intentional inverted spins.

<u>Gauge</u>	<u>Spin Indications</u>	<u>Remarks</u>
Altimeter	Rapidly decreasing	May indicate up to 1000 feet above actual altitude.
AOA	0 units (pegged)	Stalled
Airspeed	40 KIAS	Stable
Turn Needle	Pegged in direction of spin	Spin rate: 120° per sec.
VSI	6000 fpm (pegged)	Approx 9000 fpm
Attitude Gyro	May be tumbling	30° Nose down

Table 5-2 T-6B Indications of an Inverted Spin
(characterized by nose-down, upside down attitude, and negative Gs)

A flat spin is characterized by a flat attitude and transverse or “eyeball out” Gs. Since the relative wind is from directly below the airplane, the control surfaces are ineffective. The cockpit indications will be similar to an erect spin, except airspeed may vary depending on how flat the spin is. The T-6B is aerodynamically incapable of entering a flat spin.

Recovery Phase

The spin recovery is the most positive recovery available and is 100% effective when properly applied.

1. **Gear, flaps, and speed brake – Retracted**
2. **PCL – IDLE**
3. **Rudder – Full opposite to turn needle deflection**
4. **Control stick – Forward of neutral with ailerons neutral**
5. **Smoothly recover to level flight after spin rotation stops**

If the pilot is hanging in the straps, he is in an inverted spin. Inverted spin direction is hard to determine visually, so the turn needle should be referenced. Recovery instructions can be found in the T-6 Flight Manual (NATOPS). The spin will recover to a steep, inverted, nose down dive. Roll or split-S out of the dive to level flight in a timely manner as airspeed will build rapidly.

If proper recovery procedures are not followed, a progressive or aggravated spin could result. A **progressive spin** will result if, during the recovery phase, the pilot puts in full opposite rudder but inadvertently maintains full aft stick. After one or two more turns in the initial spin direction, the nose will pitch steeply down and the airplane will snap into a reversed direction of rotation. The spin reversal is disorienting and significantly more violent than a normal erect spin entry. No matter how disorienting and violent the entry may be, remember to look at the turn needle to determine spin direction. To recover, apply full rudder opposite the turn needle and stick slightly forward of neutral. When rotation stops, the horizon should be referenced to maintain a wings level attitude during the pull-out.

An **aggravated spin** is caused by maintaining pro-spin rudder while moving the control stick forward of the neutral position. Neutralizing rudder while advancing the stick may also be sufficient to enter an aggravated spin. Aggravated spins are characterized by a steep nose-down pitch attitude (approximately 70° nose down) and an increase in spin rate (approximately 280° per second). In addition, aggravated spins tend to induce severe pilot disorientation. Recovery procedures from an aggravated spin are the same as from a progressive spin.

ASSIGNMENT SHEET 2-5-3

SPINS REVIEW

A. INTRODUCTION

This lesson covers fundamental information on the aerodynamic causes and characteristics of aircraft spins. At the completion of this lesson, you will be able to define and state the causes of a spin and describe the aerodynamic factors affecting spin development.

B. ENABLING OBJECTIVES

C. STUDY ASSIGNMENT

1. Review Naval Aviation Fundamentals, NAVAVSCOLSCOM-SG-200 Unit 2, Chapter 5
2. Read Naval Aviation Fundamentals, NAVAVSCOLSCOM-SG-200 Unit 2, Chapter 6

D. STUDY QUESTIONS

1. What two conditions must be present in order for an aircraft to spin?
2. How does the introduction of yaw affect the lift and drag of a stalled wing?
3. What conditions must be present to enter an inverted spin?
4. What is the main aerodynamic factor affecting spins?
5. What causes an accelerated spin?
6. In a right spin, which rudder position will provide the greatest anti-spin forces?
7. How can a progressive spin be entered?

8. Which aircraft will enter a spin slower, with less oscillation, and take longer to recover?



9. Which aircraft will spin at a lower pitch attitude and higher rotation rate?



Answers:

1. Stall and yaw
2. Causes asymmetrical lift and drag between the outside and inside wing
3. Negative G stall and yaw introduced
4. Conservation of angular momentum
5. Spinning with the control stick anywhere other than full aft
6. Full left rudder
7. By maintaining full aft stick while applying and holding anti-spin rudder
8. 6000 pound aircraft
9. Right spin
 - a. Stabilizes at lower pitch
 - b. Stabilizes more slowly with increased oscillations
 - c. Rotation rate increased

OUTLINE SHEET 2-6-1

WAKE TURBULENCE AND WIND SHEAR

A. INTRODUCTION

This lesson discusses the causes of, hazards created by, and procedures to be followed for wake turbulence and wind shear. When the lesson is completed, you will have a basic understanding of these flying hazards and the procedures used to avoid them.

B. ENABLING OBJECTIVES

2.187 DESCRIBE wake turbulence, in a classroom, in accordance with Naval Aviation Fundamentals, NAVAVSCOLSCOM-SG-200

2.188 DESCRIBE the effects of changes in weight, configuration, and airspeed on wake turbulence intensity, in a classroom, in accordance with Naval Aviation Fundamentals, NAVAVSCOLSCOM-SG-200

2.189 DESCRIBE the effects of wake turbulence on aircraft performance, in a classroom, in accordance with Naval Aviation Fundamentals, NAVAVSCOLSCOM-SG-200

2.190 STATE the takeoff and landing interval requirements for the T-6B, in a classroom, in accordance with Naval Aviation Fundamentals, NAVAVSCOLSCOM-SG-200

2.191 DESCRIBE procedure for wake turbulence avoidance during takeoff, in a classroom, in accordance with Naval Aviation Fundamentals, NAVAVSCOLSCOM-SG-200

2.192 DESCRIBE procedure for wake turbulence avoidance during landing, in a classroom, in accordance with Naval Aviation Fundamentals, NAVAVSCOLSCOM-SG-200

2.193 DEFINE wind shear, in a classroom, in accordance with Naval Aviation Fundamentals, NAVAVSCOLSCOM-SG-200

2.194 STATE the conditions that will lead to an increasing performance wind shear, in a classroom, in accordance with Naval Aviation Fundamentals, NAVAVSCOLSCOM-SG-200

2.195 STATE the conditions that will lead to a decreasing performance wind shear, in a classroom, in accordance with Naval Aviation Fundamentals, NAVAVSCOLSCOM-SG-200

2.196 DESCRIBE the effects of wind shear on aircraft performance, in a classroom, in accordance with Naval Aviation Fundamentals, NAVAVSCOLSCOM-SG-200

2.197 DESCRIBE procedures for flying in and around wind shear, in a classroom, in accordance with Naval Aviation Fundamentals, NAVAVSCOLSCOM-SG-200

2.198 DESCRIBE wind shear avoidance techniques, in a classroom, in accordance with Naval Aviation Fundamentals, NAVAVSCOLSCOM-SG-200

C. TOPIC OUTLINE

1. Introduction
2. This Lesson Topic
3. Wake Turbulence
4. Wind Shear
5. Summary and Review
6. Application
7. Assignment

INFORMATION SHEET 2-6-2

WAKE TURBULENCE AND WIND SHEAR

A. INTRODUCTION

This lesson discusses the causes of, hazards created by, and procedures to be followed for wake turbulence and wind shear. When the lesson is completed, you will have a basic understanding of these flying hazards and the procedures used to avoid them.

B. REFERENCES

1. Aerodynamics for Naval Aviators, NAVAIR 00-80T-80
2. Introduction to the Aerodynamics of Flight, NASA SP-367
3. T-6 Joint Primary Pilot Training, AETC / CNATRA Syllabus P-V4A-J NATOPS Flight Manual

C. INFORMATION

Wake Turbulence

The spanwise airflow that moves around the wingtip does more than just create induced drag, it also creates wingtip vortices. **Wingtip vortices** are spiraling masses of air that are formed at the wingtip when an airplane produces lift (Figure 6-1). This disturbance is often called “jetwash” or “wake turbulence”. Flying into another aircraft’s wing vortex can lead to a variety of dangerous situations including structural damage. Vortices may instantly change the direction of the relative wind and cause one or both wings of the trailing airplane to stall, or disrupt airflow in the engine inlet inducing a compressor stall.

The strength of a vortex depends on three main factors: airplane weight, airplane speed, and wing shape. To maintain level flight, a heavier airplane must produce more lift, and will therefore have a greater pressure differential at the wingtip where the vortex is created. Because weight is the most significant factor in the strength of wingtip vortices, the FAA has divided aircraft into three weight classes: Small aircraft (up to 41,000 lbs), large aircraft (41,000 to 255,000 lbs), and heavy aircraft (255,000 lbs or more). The FAA requires heavy aircraft to use the word “heavy” in terminal area radio communications. Vortex strength has a direct correlation to induced drag, the greater the induced drag the stronger the vortex. Since induced drag is dominant at lower airspeeds, a slower aircraft will have stronger vortices. Also, a faster aircraft will spread the vortices

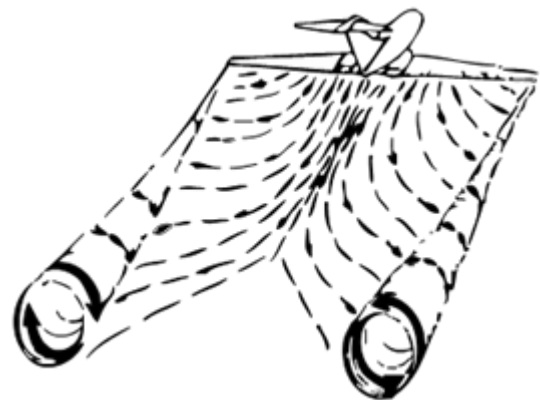

Figure 6-1 Wingtip Vortices

energy over a greater distance, reducing the effect of the vortex. Configuration also plays a significant role in vortex strength. If the flaps are lowered, more lift is created at the wing root, which decreases the pressure differential at the wingtip. The greatest vortex strength occurs when the generating airplane is heavy, slow, and clean. It is important to note that all aircraft, regardless of size, speed, or configuration generating lift produce a vortex hazard.

The diameter of the core of the vortex is about one fourth of the generating aircraft's wingspan. As vortices trail behind the aircraft, they remain within about three-fourths of the generating aircraft's wingspan. Because of the close proximity, the vortices tend to merge creating a larger field of influence called the wake turbulence zone. The **wake turbulence zone** is the region behind the aircraft containing the trailing vortices, and the region between them.

They sink at a rate of 400 to 500 feet per minute and level off about 900 feet below the flight path of the generating airplane. Vortices will lose strength and break up after a few minutes. Atmospheric turbulence will accelerate this breakup.

Hazards

The primary hazard to aircraft is loss of control caused because of induced roll. Wing vortices generate sufficient airflow to exceed the roll control capability of an airplane flying into the vortex. In cases where the wingspan and ailerons of the encountering airplane extend beyond the rotational flow of the vortex counter control is usually effective against induced roll. It is more difficult for airplanes with short wingspans (compared with the vortex generating airplane) to counter the induced roll (Figure 6-2). Pilots of short wingspan airplanes, even of the high performance type, must be especially alert to vortex encounters. The most significant factor affecting your ability to counteract the roll induced by the vortices is the relative wingspan between the two airplanes.

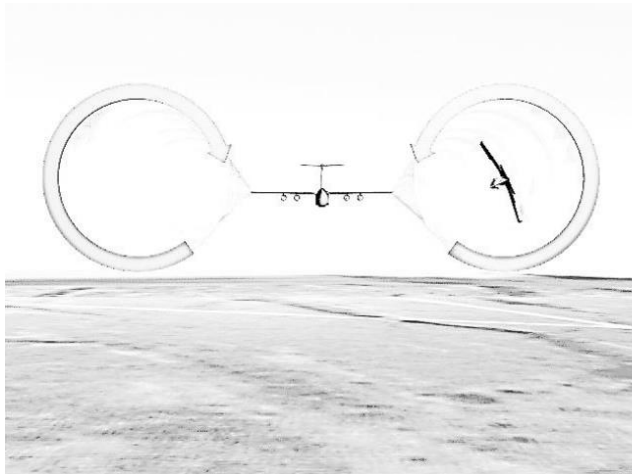

Figure 6-2

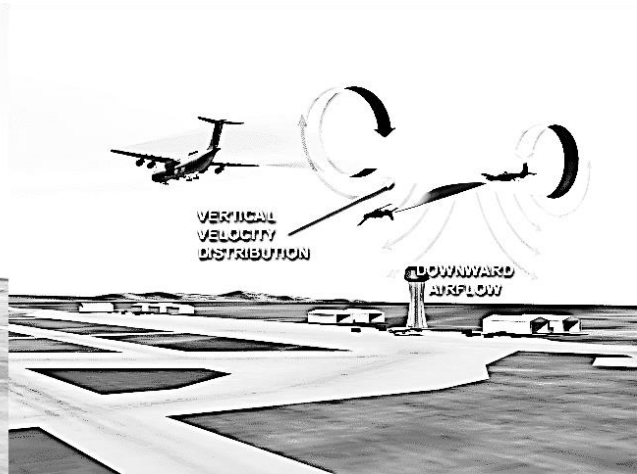

Figure 6-3

Along with induced roll, a second hazardous condition exists called the induced flow field. An **induced flow field** is created by the interactions of both vortices resulting in a downwash, between the vortices, of up to 1500 feet per minute. This can be disastrous to an aircraft that are already descending at a low power setting (Figure 6-3).

Helicopters also create unique hazards in the airfield environment. When a helicopter is in a hover it creates a tremendous downwash similar to other prop/jet blasts from aircraft. Because of the extreme downwash, small aircraft should avoid operating within 3 rotor diameters of any hovering helicopter (Figure 6-4). When a helicopter is in forward flight, it produces twin vortices similar to wingtip vortices. Therefore, pilots should give helicopters the same spacing consideration as conventional airplanes of similar size and weight.

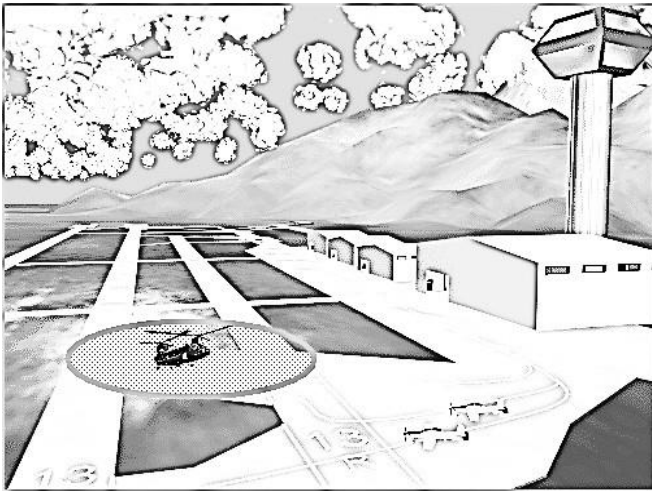

Figure 6-4

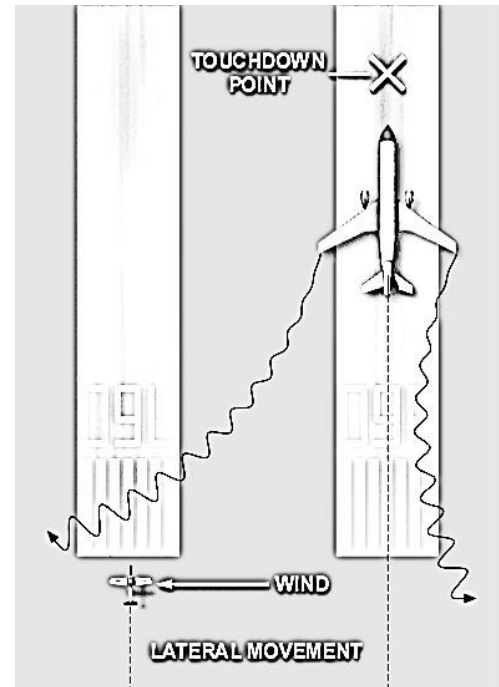

Figure 6-5 Lateral Vortex Movement

Avoidance

Most accidents involved with wake turbulence occur during takeoff and landing operations, due to the limited altitude with which to recover. Since vortices are a by-product of lift, they are generated from the moment an airplane rotates for takeoff until the airplane nosewheel touches down for landing.

Once the vortex comes in contact with the ground, it will move laterally outward at about 5 knots. A crosswind of 4 to 6 knots will cause the upwind vortex to remain stationary while the downwind vortex will move at a rate of 6 to 10 knots. This may result in the upwind vortex remaining in the touchdown zone, and the downwind vortex drifting over a parallel runway (Figure 6-5). Use caution when operating on parallel runways less than 2,500 feet apart.

The most important technique for dealing with wing tip vortices/wake turbulence is avoidance. To help avoid unexpected encounter with vortices created by landing and departing aircraft, the T-6B's **minimum takeoff spacing** requirement is 2 minutes behind a heavy aircraft (over 255,000 pounds). The same spacing is recommended for large aircraft (41,000-255,000 pounds) as well. For landing, the **minimum landing spacing** requirement is 3 minutes behind a heavy aircraft (over 255,000 pounds).

In addition to the minimum spacing requirements, pilots can adjust their rotation and landing points to avoid wake turbulence. Because wingtip vortices are not created until the departing aircraft's nosewheel lift from the runway, there are no hazards associated with wake turbulence before the liftoff point. Upon landing, once the nosewheel contacts the runway, the hazard ceases as well.

When taking off behind a larger airplane that is departing ahead of you, ensure your rotation is complete at least 300 feet prior to the larger airplane's point of rotation and conduct your climb-out to remain above his flight path (Figure 6-6C). If departing after a larger aircraft has landed, plan to rotate at a point forward of where the larger aircraft's nosewheel touched down (Figure 6-6D). These techniques will ensure you will not be climbing through any wake turbulence after takeoff.

When landing behind a larger airplane, besides observing the minimum spacing requirement, stay at or above the larger airplane's final approach path and land beyond its nosewheel touchdown point (Figure 6-6A). If a larger airplane performs a touch-and-go or low approach, observe the required spacing interval. When landing behind a larger aircraft that has just departed, ensure that your touchdown point is prior to the larger aircraft's rotation point (Figure 6-6B). This will ensure that you avoid flying through wake turbulence on short final or in the flare.

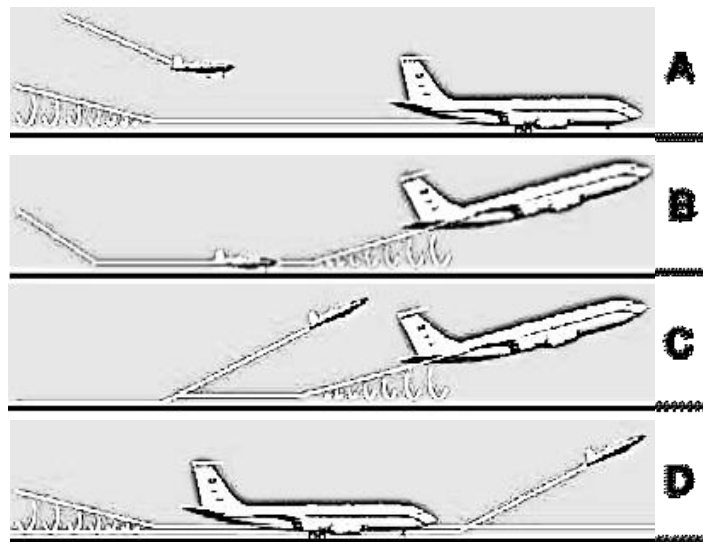

Figure 6-6 Vortex Avoidance

During formation flying and in-flight refueling, airplanes close to one another produce a mutual interference especially when the trailing airplane is slightly aft and below the lead airplane. The leading airplane experiences an effect that is similar to ground effect because of a reduction in downwash and induced drag. For the second airplane, this mutual interference of the flow pattern can instantaneously alter the direction of the relative wind that the airfoils are sensing. Flying through lead's flightpath will place you in wake turbulence, which could result in an over-G or a flameout.

When operating on intersecting runways, or parallel runways within 2500 feet of each other, you must be alert to adjacent large aircraft operations, particularly upwind of your runway (Figure 6-5). A large aircraft executing a takeoff, low approach, or landing can severely affect your runway and flight path. Adjust your takeoff or landing point to avoid possible wake turbulence and assure that an interval of at least 2 minutes has elapsed before you attempt to takeoff or land.

Wind Shear

Wind shear is defined as a sudden change in wind direction and/or speed over a short distance in the atmosphere. Wind shear boundaries can be vertical or horizontal and vary in intensity. Weak shears distribute the wind change from one body of air to the other gradually. A pilot flying through this type of shear may not even notice a change in aircraft performance. On the other hand, strong shears distribute the wind abruptly creating rapid changes in aircraft performance. Wind shear is most often caused by jet streams, land or sea breezes, fronts, inversions and thunderstorms.

Wind shears can be very complex combinations of wind velocities. Usually the more complex the wind shear, the more difficult it is for the pilot to react correctly. To simplify things we will limit our discussion in this section to horizontal wind shears so that we may gain a basic understanding of how wind shear will affect aircraft performance.

Wind shears change airflow over the aircraft. The velocity of the relative wind can be altered causing immediate changes in the indicated airspeed and/or angle attack of the aircraft. Once the aircraft is stabilized in the body of air it behaves as if nothing happened. You have probably experienced this effect while riding on a moving sidewalk or escalator. As you step onto these moving surfaces you feel a little unstable for a few seconds. Shortly thereafter, you stabilize and function normally. The only difference is your “groundspeed” is now a little faster.

If we confine ourselves to the horizontal plane, we can say wind shear either causes an increase or decrease in aircraft performance. With ample airspeed and altitude, wind shear does not pose a serious threat. However during slow airspeed and low altitude operations, such as during takeoffs and landings, wind shear becomes hazardous.

Wind Shear During Takeoff

Increasing Performance Wind Shear: Figure 6-7 shows an aircraft passing through a wind shear which increases headwind by 20 knots resulting in an increase of dynamic pressure by 20 knots. Because IAS is directly proportional to dynamic pressure, IAS will instantly increase by 20 knots. The increase in IAS results in an increase in lift and therefore causes an initial increase in performance. Also, a 20 knot increase in headwind will reduce our ground speed by 20 knots, resulting in a steeper angle of climb. As long as a proper climb attitude is maintained, a wind shear with an increasing headwind component on takeoff does not pose a serious threat.

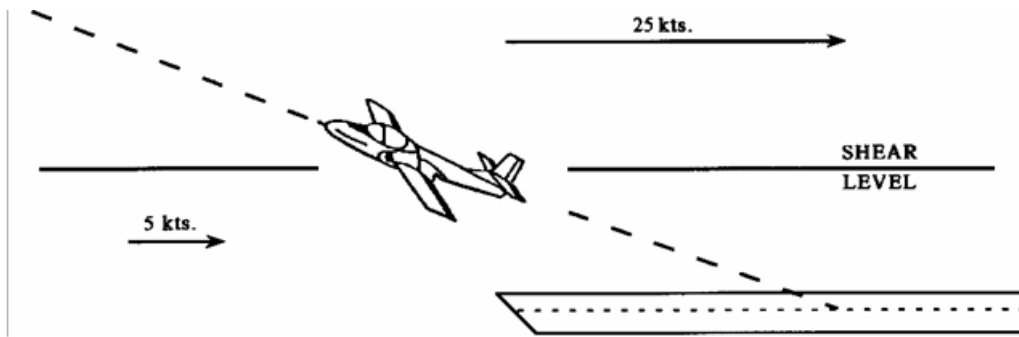

Figure 6-7 Increasing Performance Wind Shear on Takeoff

Decreasing Performance Wind Shear: Figure 6-8 shows an aircraft entering a shear which decreases the indicated airspeed by 25 knots. This causes a significant decrease in performance. The drop in dynamic pressure reduces lift and also results in a shallower angle of climb. A rapid drop of airspeed can place an aircraft near stall speed. An increase in angle of attack in this situation will probably result in an approach to stall indication and possibly a stall. This example illustrates how shear can be dangerous during a decreasing performance wind.

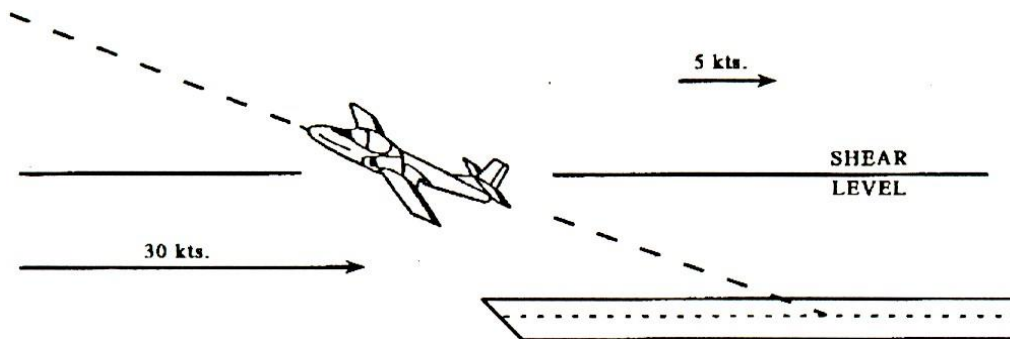

Figure 6-8 Decreasing Performance Wind Shear on Takeoff

Wind Shear During Landing

An aircraft established on a glidepath for landing is usually trimmed for a constant airspeed descent. Any change in indicated airspeed will cause a change in pitch due to trim and a change in the rate of descent. The pilot will have to make quick control inputs to maintain the desired glidepath.

Increasing Performance Wind Shear: Figure 6-9 shows an aircraft descending through a shear which increases its indicated airspeed. Notice that the transition from a tailwind to zero wind causes an increase in performance. This shear increases lift and causes the aircraft to pitch up and rise above the glidepath. If the pilot is slow to recognize the wind shear, a steep fast approach can quickly develop. This may result in significantly longer landing distances, a hazard that will vary depending on the runway environment (runway length, icy, wet, etc.). An overly aggressive correction can lead to a high rate of descent with a dangerously low power setting.

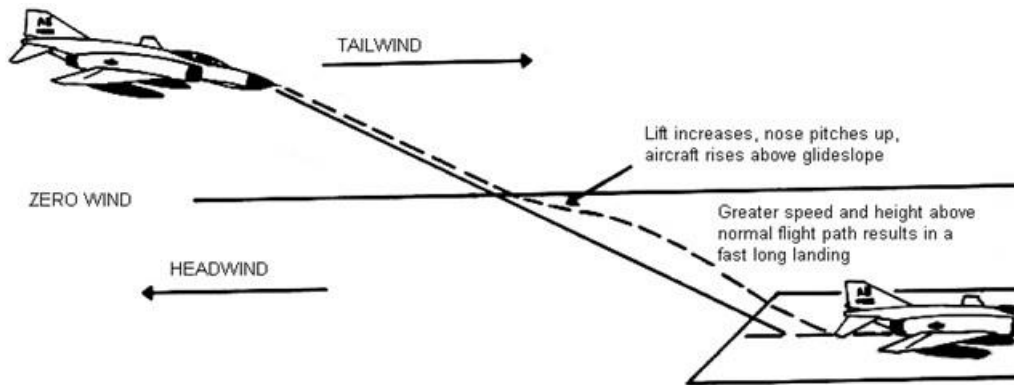

Figure 6-9 Increasing Performance Wind Shear on Landing

For the purpose of comparing relative power settings, assume a hypothetical thrust scale of from 1 to 10, and that the normal no-wind power setting is 6. Because of the tailwind (higher groundspeed) above the shear, the pilot needs a power setting of 5 to maintain the glidepath. When the aircraft crosses the shear and begins to rise above glidepath, the pilot reduces power to 4. As the aircraft returns to glidepath, a power setting of 6 will be required to maintain the glidepath. This is due to the lower rate of descent required by a slower groundspeed. Notice that a higher power setting is required after the shear than before the shear to maintain the glidepath. In other words, you must eventually add more power than was removed to stabilize on the glidepath.

If too much power is removed, combined with an overly aggressive correction back to the original glidepath, there may be insufficient altitude for the pilot to recover, resulting in landing short of the runway (Figure 6-10). If a strong wind shear is encountered at low altitudes a wave-off/go-around can be executed if necessary.

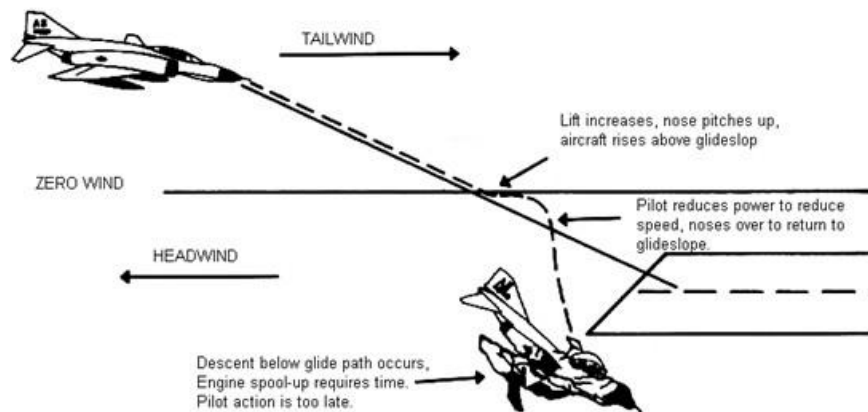

Figure 6-10 Increasing Performance Wind Shear on Landing Resulting in Landing Short

Decreasing Performance Wind Shear: A decreasing performance wind shear on landing is one of the most hazardous situations a pilot can encounter. Figure 6-11 shows an aircraft descending through a shear which decreases its indicated airspeed. This shear causes the aircraft to pitch down and descend below the glidepath. The pilot counters this by adding power and raising the nose. However, the pilot may over correct and rise above the glidepath. Once back on glidepath, a lower power

setting will be required to compensate for the higher ground speed and new rate of descent within the new body of air.

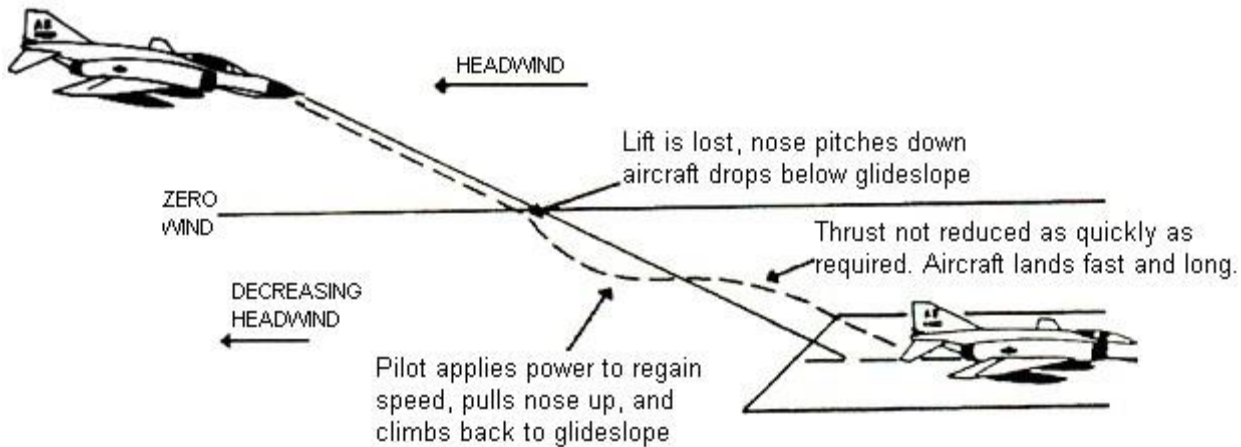

Figure 6-11 Decreasing Performance Wind Shear on Landing

Again assuming a thrust scale of from 1 to 10, we can examine the power requirements during this type of shear. Let's assume the normal no-wind power setting of 6. Because of the headwind above the shear, the pilot needs a power setting of 7 to maintain the glidepath. Then the aircraft crosses the shear and begins to descend below glidepath, the pilot increases power to 8 or 9. As the aircraft returns to glidepath, a power setting of 6 will be required to maintain it. Again, this is because of the higher rate of descent dictated by a higher groundspeed. The point to remember is that you must eventually reduce power by more than the amount added to stabilize on the glidepath.

If a strong decreasing performance wind shear is encountered at very low altitude, or if a pilot is slow to recognize the situation, there may be insufficient time and power to overcome the resulting loss of lift (Figure 6-12) and landing short of the runway.

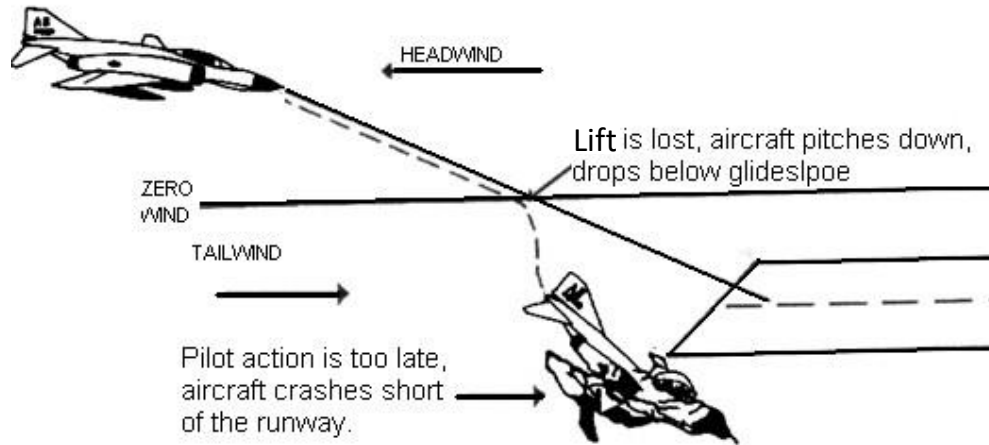

Figure 6-12 Decreasing Performance Wind Shear on Landing Resulting in a Landing Short

Wind Shear Avoidance

The best technique for dealing with wind shear is to avoid it. If a moderate to strong wind shear is expected, delay your takeoff or landing until the shear condition no longer exists. Anytime wind shear is experienced, pilots should consider going around. If airborne and unable to delay, consider diverting to a place with more favorable conditions.

Strong shears like those associated with microburst activity must be avoided at all cost. An aircraft encountering a microburst will initially experience a strong, increasing performance wind shear. This will cause the aircraft to pitch up and climb. A pilot's natural reaction is to apply nose down stick. Soon after, the aircraft will experience a strong, decreasing performance wind shear. Combined with the nose-down stick applied by the pilot, the decreasing performance wind shear can result in impacting the terrain. These wind shears can be anywhere from 50 knots to 200 knots and can occur in a relatively short period and severely impair an aircraft's ability to maintain controlled flight, especially at low altitude. Downdrafts exceeding 700 feet per minute have also been measured.

Methods of Wind Shear Detection

Because wind shear is such a dangerous phenomenon, early detection is vital to mishap prevention. In most wind shear accidents there have been warning signs that were ignored, misinterpreted or misunderstood. You must evaluate the warning signs and make a decision quickly and decisively. Fortunately, there are several methods to help pilots detect and avoid wind shear.

Departure or, arrival weather reports calling for gusty winds, heavy rain or thunderstorms should be a clue that a high potential for microburst activity exists. When you receive your pre-flight briefing or call ahead for an en route update, be alert for any convective activity that might be forecast or building. It is important to remember that weather changes very quickly. The best briefing may not prepare you for every situation that you may encounter.

Visual cues are very important because they help substantiate the information given by the weather guesser. In fact, in many fatal wind shear mishaps the pilot continued the approach or takeoff in

visible and known thunderstorm conditions. Visual cues include virga, localized blowing dust (especially in circular or elliptical patterns), rain shafts with rain diverging away from the core of the cell, and of course an indication of lightning or tornado-like activity.

Wind Shear Alert Systems are another source of information about potential wind shear activity. There are several types in operation today at many civilian fields, especially those with a history of strong winds. For example the Low Level Wind Shear Alert System (LLWAS) measures the wind speed and direction at several points on the ground and compares them with a reference sensor located near the center of the airfield. Because of the small diameter of microbursts, many may go undetected. When they are detected, they are on the field and it may be too late. There are also some Doppler radar systems which show greater accuracy in wind shear warnings. A NEXRAD Doppler radar system is a ground based radar that can very accurately detect microburst activity. Systems onboard modern aircraft monitor changes in wind velocity and aircraft acceleration to provide wind shear warning and pitch guidance to help escape wind shear. Many modern commercial and military aircraft that have onboard system to monitor changes in wind velocity and aircraft acceleration to provide warning to the crew. In most onboard systems, the surface winds are loaded by the pilot. The computer is then able to constantly compare current winds with surface winds and alert the aircrew if the difference becomes significant. In more advanced onboard systems, aircraft pitch, airspeed, and other guidance is displayed to help pilots negotiate wind shear. Unfortunately, these systems are not on our trainer aircraft.

PIREPS and Weather Alerts are one of the best sources of wind shear information. Because of the short lifespan and localized nature of wind shear and microbursts, PIREPS are sometime the only way to disseminate information in a timely manner. If you encounter wind shear, it is imperative that you make a PIREP to approach control or tower so they may notify other aircrews. Your PIREP should include the location where the shear was encountered, an estimate of its magnitude and most importantly a description of what was experienced, such as turbulence, airspeed gain or loss, glidepath problems, etc.

Takeoff and Landing Procedures

If wind shear cannot be avoided, here are some T-6B specific procedures to be used in areas of suspected wind shear.

For takeoff:

Use the longest suitable runway. Consider crosswind, obstacles, runway surface conditions, etc., when selecting the runway.

Use takeoff flaps, but delay rotation (V_{ROT}) by the amount of predicted wind shear (up to 10 additional knots). Notice, this addition applies to increasing performance wind shear.

Rotate to normal climb attitude at increased V_{ROT} and maintain attitude.

If wind shear is encountered near V_{ROT} , abort if possible.

For Landing:

Set flaps to takeoff and increase approach speed by the amount of wind shear potential (up to 10 knots above normal). Again, notice this addition applies to increasing performance wind shear. By setting the flaps to takeoff, there will be less drag and the aircraft will be able to accelerate more quickly.

Establish the proper approach pitch, trim, and power settings by 1000 AGL. Resist the temptation to make large power reductions. Keep in mind that increased landing speed means longer landing distances.

ASSIGNMENT SHEET 2-6-3

WAKE TURBULENCE AND WIND SHEAR REVIEW

A. INTRODUCTION

This lesson discusses the causes of, hazards created by, and procedures to be followed for wake turbulence and wind shear. When the lesson is completed, you will have a basic understanding of these flying hazards and the procedures used to avoid them.

B. ENABLING OBJECTIVES

C. STUDY ASSIGNMENT

1. Review Naval Aviation Fundamentals, NAVAVSCOLSCOM-SG-200 Unit 2, Chapter 6

D. STUDY QUESTIONS

1. When viewed from behind the generating aircraft, wingtip vortices rotate _____ from the right wing and _____ from the left wing.
 - a. clockwise; clockwise
 - b. counterclockwise; clockwise
 - c. counterclockwise; counterclockwise
 - d. clockwise; counterclockwise
2. Wake turbulence is generated _____.
 - a. only by heavy aircraft
 - b. only by helicopters at hover
 - c. only when an aircraft's flaps are extended
 - d. by any aircraft whenever it is producing lift
3. When taking off behind a heavy aircraft in the T-6B, you should allow for a minimum spacing of _____ minute(s).
 - a. 1
 - b. 2
 - c. 3
 - d. 4
4. When taking off behind a heavy aircraft that has just landed, what should you do to minimize the effects of its wake turbulence?
 - a. Plan to lift off before its nose gear touchdown point
 - b. Plan to lift off after its nose gear touchdown point

5. Key hazards created by wake turbulence are _____ and _____.
 - a. low visibility; reduced engine performance
 - b. slower climb rates; adverse yaw
 - c. induced roll; induced flow field
 - d. longer takeoff distances; induced pitch changes

6. The wake turbulence generated by a heavy aircraft taking off from a parallel or intersecting runway is not a factor for aircraft operating on another runway.
 - a. True
 - b. False

7. How will a wind shear that decreases your headwind component by 20 knots affect your aircraft?
 - a. Indicated airspeed will decrease 20 knots thereby decreasing lift.
 - b. Indicated airspeed will increase 20 knots thereby increasing lift.
 - c. Indicated airspeed will decrease 20 knots thereby increasing lift.
 - d. There would be no appreciable effect.

8. During an approach, you pass through a shear that changes the wind from a 10 knot tailwind to a 10 knot headwind. How will this shear affect your aircraft?
 - a. Indicated airspeed will increase by 10 knots, lift will decrease, and aircraft will tend to descend below glidepath.
 - b. Indicated airspeed will increase by 20 knots, lift will decrease, and aircraft will tend to descend below glidepath.
 - c. Indicated airspeed will increase by 20 knots, lift will increase, and aircraft will tend to climb above glidepath.
 - d. Indicated airspeed will decrease by 10 knots, lift will decrease, and aircraft will tend to climb above glidepath.

9. What wind changes would an aircraft initially encounter if flown through a microburst?
 - a. A strong headwind
 - b. A strong tailwind

10. An aircraft reported wind shear on final with a 10 knot loss of airspeed. How should you adjust your approach?
 - a. Subtract 10 knots from your approach speed.
 - b. Set flaps to "Takeoff" and maintain your normal approach speed.
 - c. Delay landing for 2 minutes.
 - d. Set flaps to "Takeoff" and add 10 knots to your approach speed.

ADDITIONAL REVIEW QUESTIONS

1. What is the definition of a stall?
2. What are the two major classifications of stalls?
3. Which type of stall will have lower stall airspeed?
4. What is the only reason the T-6B will stall?
5. What two conditions must be present in order for an aircraft to spin?
6. What causes an accelerated spin?
7. In a right spin, which rudder position will provide the greatest anti-spin forces?
8. Which aircraft will enter a spin slower, with less oscillation, and take longer to recover?
9. When taking off behind a heavy aircraft in the T-6B, you should allow for a minimum spacing of _____ minute(s).
10. When landing behind a heavy aircraft that has just landed, what should you do to minimize the effects of its wake turbulence?
11. How will a wind shear that decreases your headwind component by 20 knots affect your aircraft?
12. An aircraft reported wind shear on final with a 10 knot loss of airspeed. How should you adjust your approach and what things should you look out for?

Answers:

- 1.B 6. FALSE
- 2.D 7. A
- 3.B 8. C
- 4.B 9. A
- 5.C 10. D

Answers to Additional Lesson Review Questions:

- 1. Condition in flight where increase in AOA results in decrease in C_L .
- 2. Power-on and power-off stalls
- 3. Power-on stall
- 4. Exceeding stall AOA (18 units)
- 5. Stall and yaw
- 6. Spinning with the control stick anywhere other than full aft
- 7. Full left rudder
- 8. 6000 pound aircraft
- 9. Two
- 10. Delay landing for three minutes. In addition, you can land beyond the landing aircraft's nose gear touchdown point.
- 11. Indicated airspeed will decrease 20 knots, thereby decreasing lift.
- 12. a. Set flaps to "Takeoff"
 - b. Add 10 knots to your approach speed
 - c. Be alert for the tendency to land long

Glossary

absolute altitude The aircraft's height above the terrain directly beneath the aircraft, measured in feet above ground level (AGL). Absolute altitude is found by subtracting the terrain elevation from the true altitude.

absolute ceiling The maximum altitude above sea level in a standard atmosphere that an airplane can maintain level flight.

accelerated spin A spin in which the control stick is not held in the full aft position. An accelerated spin is characterized by steeper pitch attitudes and higher spin rates.

accelerated stall A stall in which the load factor is greater than one, as in a pullout. Usually more violent and disorienting than a normal stall.

accelerated stall line A curved line describing the number of g's that can be generated at a given indicated airspeed as a function of C_{LMAX} angle of attack for a particular airfoil. Also called line of maximum lift.

acceleration A change in the velocity of a body with respect to magnitude or direction, or both.

accelerometer An instrument that measures one or more components of the acceleration of a vehicle.

adverse pressure gradient A pressure gradient of increasing static pressure in the direction of airflow.

adverse yaw Yaw in the opposite direction of aileron roll input.

aerodynamic balance The feature of a control surface that reduces the magnitude of the aerodynamic moment around the hinge line. See shielded horn.

aerodynamic braking A technique for slowing an airplane to a speed suitable for frictional braking. Aerodynamic braking is accomplished by increasing the surface area exposed to the relative wind in order to increase parasite drag, primarily by holding the nose of the airplane in the landing attitude.

aerodynamic center (AC) The point along the chord line of an airfoil where all changes in aerodynamic force effectively take place. It is normally located at the point of 25% chord.

aerodynamic force (AF) A force acting on an airfoil that is the result of air pressure and friction distribution over the surface of the airfoil.

aerodynamics The science that studies the motion of gaseous fluid flows, and of their actions against and around bodies, and of the forces acting on bodies within that flow.

aerodynamic twist Form of wing tailoring that employs a decrease in camber and/or relative thickness from wing root to wingtip. The wing root is more positively cambered and/or thicker (relative to the chord) than the tip, resulting in a root first stall pattern. Also called section variation.

aileron A movable control surface, attached to the wing of an airplane, used to produce a rolling moment around the longitudinal axis by creating unequal lifting forces on opposite sides of an airplane.

aileron reversal Reversal of the control effect usually produced by an aileron, caused by a moment around the aerodynamic center twisting the wing and changing its angle of attack.

aircraft (AC) Any device used or intended to be used for flight in the air.

airflow A flow or stream of air. A rate of flow measured by mass per unit time.

airfoil A streamlined shape designed to produce lift as it moves through the air.

airframe The structural components of an airplane including the framework and skin of such parts as the fuselage, wings, empennage, landing gear, and engine mounts.

airplane An engine driven, heavier-than-air, fixed-wing aircraft that is supported by the dynamic reaction of airflow over its wings.

altimeter Any instrument for measuring altitude. An instrument similar to an aneroid barometer that uses the change of atmospheric pressure with altitude to indicate the approximate elevation above a given reference.

altitude The height of a point, measured from a reference plane, such as mean sea level.

ambient Pertaining to the air or air conditions around a flying aircraft but undisturbed or unaffected by it.

aneroid barometer An instrument for measuring the pressure of the atmosphere which operates on the principle of having changing atmospheric pressure bend a metallic surface which, in turn, moves a pointer across a scale graduated in units of pressure.

angle of attack (AOA, α) The angle formed between the relative wind and the chord line of the airfoil

angle of bank (AOB, ϕ) The angle between the horizon and the lateral axis of an aircraft. The angle of lateral displacement (roll) of an aircraft, especially in making a turn

angle of climb (AOC, γ) The angle between the horizon and the flightpath of a climbing aircraft.

angle of descent (γ) The angle between the horizon and the flightpath of a descending aircraft.

angle of incidence The angle between the airplane's longitudinal axis and the chord line of its wing. The root chord is commonly chosen to measure the angle of incidence.

angular acceleration Rate of change of angular velocity.

anhedral angle A negative dihedral angle. Also called cathedral angle.

approach A specified flightpath and associated altitudes to be flown in preparation for a landing, especially a published instrument approach.

artificial feel A method of simulating, altering, or otherwise enhancing the feedback or control feel that is transmitted to the cockpit controls by the forces acting on the control surfaces.

aspect ratio (AR) The ratio of the wingspan to the average chord.

attitude The orientation of an aircraft as determined by the relationship between its axes and some reference line or plane. Usually refers to nose attitude or pitch attitude.

automatic slot High lift device that consists of a movable vane attached to the leading edge of the wing that moves away from the body of the wing to allow airflow from below the wing to reach the upper surface and reenergize the boundary layer, delaying boundary layer separation. See slat.

autorotation During a spin, a combination of roll and yaw that is self-sustaining.

average chord (c) The geometric average of every chord from the wing root to the wingtip. Also called mean geometric chord.

axis A reference line passing through a body, around which the body rotates.

axis system A set of three mutually perpendicular axes, intersecting at the center of gravity of an aircraft, around which the motions, moments, and forces of roll, pitch, and yaw are measured.

bank The position or attitude of an aircraft when its lateral axis is inclined from the horizontal.

Bernoulli's Equation $P_T = P_S + q$. (After Daniel Bernoulli, 1700-1782, Swiss scientist.) In aerodynamics, a law or theorem stating that in a flow of incompressible fluid, the sum of the static pressure and the dynamic pressure along a streamline is constant if gravity and frictional effects are disregarded.

boundary layer The layer of airflow over the surface of an airfoil, which shows local airflow retardation caused by viscosity. The boundary layer is very thin at the leading edge of an airfoil (about 1 mm) and grows in thickness as it moves over a body. It is composed of laminar flow and turbulent flow.

boundary layer control (BLC) The control of the airflow within the boundary layer in order to prevent its separation at high angles of attack. See also slot and slat.

buffeting The beating, shaking, or oscillation of an aircraft's structure or surfaces by an unsteady flow, gusts, turbulence, etc.

cabin Compartment of an aircraft in which passengers, troops, or cargo are loaded.

calibrated airspeed (CAS) Indicated airspeed corrected for instrument error.

calibrated altitude Indicated altitude corrected for instrument error.

camber The curvature of the mean line of an airfoil from leading edge to trailing edge; the amount of this curvature.

cantilever A beam or object supported only at or near one end, or one point; without external bracing.

cathedral See anhedral.

center of gravity (CG) The point at which the weight of an object is considered to be concentrated.

chord A measure of the chord line from the leading edge to the trailing edge of an airfoil. The chord may vary in length from the wingtip to wing root. The root chord, c_R , is the chord at the wing centerline and the tip chord, c_T , is measured at the wingtip.

chord line An infinitely long, straight line drawn through the leading and trailing edges of an airfoil.

chordwise flow Airflow perpendicular to the leading edge of an airfoil; airflow along the chord of an airfoil. Since chordwise flow is accelerated over a wing, it produces lift.

cockpit Compartment of an aircraft in which the flight crew, especially the pilot(s), are located. The cockpit is where the aircraft is controlled from.

coefficient of aerodynamic force (C_F) The dimensionless portion of the aerodynamic force that is a function of angle of attack, camber, aspect ratio, compressibility, and viscosity.

coefficient of drag (C_D) The dimensionless portion of the total drag on an airfoil that is dependent on the same variables that affect C_F .

coefficient of friction (μ) A dimensionless number whose value depends primarily on the type of material and condition of the two surfaces that are in contact.

coefficient of lift (C_L) The dimensionless portion of the total lift on an airfoil that is dependent on the same variables that affect C_F .

compressibility The property of a substance that allows its density to increase as pressure increases.

compressible flow Flow at speeds sufficiently high that density changes in the fluid can no longer be neglected.

constant-speed propeller A propeller designed to maintain engine speed at a constant RPM, automatically increasing or decreasing pitch as engine speed tends to increase or decrease.

continuity equation $\rho_1 A_1 V_1 = \rho_2 A_2 V_2$. Principle of physics that states that for fluids, the mass flow rate has the same value at every position along a closed tube.

control feel The feel or impression of the stability and control of an aircraft that a pilot receives through the cockpit controls, either from aerodynamic forces acting on the control surfaces or from devices simulating these aerodynamic forces.

control force A force, either aerodynamic or pilot induced, acting on a control surface.

control horn A short lever or rigid post attached to a control surface, to which a control cable, wire, line, or rod is attached.

controllability The capability of an aircraft to respond to control inputs, especially in direction or attitude.

control stick A lever for controlling the movements of an aircraft in flight. On a fixed-wing airplane, the control stick operates the elevators by a fore-and-aft movement and the ailerons by a side-to-side movement.

control surface A movable airfoil or surface, such as an aileron, elevator, rudder, or spoiler used to control the attitude or motion of an airplane and to guide it through the air.

cosine (cos) In a right triangle, the function of an acute angle that is the ratio of the length of the adjacent side to the length of the hypotenuse.

creep The gradual reduction in a material's strength over time due to high temperature and stress. Also known as plastic deformation.

critical altitude The maximum altitude at which, in the standard atmosphere, an engine produces its sea level rated horsepower or torque.

critical Mach number (M_{CRIT}) The free airstream Mach number that produces the first evidence of local sonic flow.

crosswind A wind blowing across the flightpath of an airplane.

density (ρ) Mass per unit volume.

density altitude (DA) Density altitude is pressure altitude corrected for nonstandard temperature. Density altitude is the pressure altitude on a standard day that has the same density as the ambient air.

dihedral angle The angle between the spanwise inclination of a wing and the lateral axis. It is the upward slope of the wings when viewed from head on. A negative dihedral is called anhedral.

directional control Control of the longitudinal axis around the vertical axis; yaw control.

directional divergence A departure from equilibrium around the vertical axis caused by negative directional static stability. Condition of flight in which the reaction to a small initial sideslip is an increase in sideslip angle. This would result in the airplane yawing broadside to the relative wind.

directional moment A moment created around an aircraft's vertical axis.

directional stability The stability of an aircraft around its vertical axis. The reaction of an aircraft to a sideslip.

dive A steep descent, usually power on.

downwash Chordwise airflow from the upper surface of an airfoil passing downward behind the trailing edge to the lower surface. Downwash decreases the amount of lift produced by the wing. Any downward moving airflow.

drag (D) That component of the aerodynamic force acting parallel to, and in the same direction as the relative wind. It acts as a retarding force.

Dutch roll Dynamic stability that is the result of strong lateral and weak directional static stability. An airplane prone to Dutch roll would appear to describe a figure eight on the horizon and would tail wag.

dynamic pressure (q) The pressure of a fluid resulting from its motion, equal to one half the density times the velocity squared ($q=1/2\rho V^2$).

dynamic stability The oscillatory motion of a body, beyond its initial tendency to move toward or away from equilibrium, after a disturbance. A measure of displacement with respect to time.

elastic limit The maximum load that may be applied to a component without permanent deformation.

elevator A control surface, attached to a horizontal stabilizer that produces a pitching moment around the airplane's lateral axis.

empennage The assembly of stabilizing and control surfaces at the tail of an airplane.

endurance The length of time that an aircraft can fly under specified conditions without refueling.

energy The ability or capacity to do work, expressed in foot-pounds.

equilibrium Flight condition that exists when the sum of the forces and moments acting around the center of gravity equal zero. The absence of linear or angular acceleration.

equivalent airspeed (EAS) The true airspeed at sea level on a standard day that produces the same dynamic pressure as the actual aircraft condition. It is equal to calibrated airspeed corrected for the compressibility of air.

equivalent parasite area (f) The total surface area of an airplane that contributes to parasite drag. Normally less than cross sectional area due to the effects of streamlining.

erect spin A spin characterized by positive Gs and an upright attitude.

fatigue failure The breaking (or serious permanent deformation) of a material due to a cyclic application of load or force.

fatigue strength A measure of a material's resistance to a cyclic application of load or force.

feathered propeller A propeller whose blades have been rotated so that the leading and trailing edges are nearly parallel with the aircraft flightpath to minimize drag and to stop propeller rotation.

feedback The transmission of forces initiated by aerodynamic action on control surfaces to the cockpit controls. The actual forces transmitted to the cockpit controls.

fence A stall fence.

final / final approach That portion or leg of an approach pattern after the last turn, in which the aircraft is in line with the runway in the landing direction.

finite wing A wing with a finite span; a wing with wingtips.

fixed slot A slot that remains open at all times.

flap A high lift device consisting of a hinged, pivoted, or sliding airfoil or plate, or a combination of such objects regarded as a single surface, extended or deflected for increasing camber. Used primarily to decrease the takeoff or landing velocity.

flat spin A spin characterized by transverse Gs and an attitude flatter than an erect spin.

flightpath (FP) The path described by an airplane's center of gravity as it moves through an air mass.

flow separation The breakaway of the boundary layer airflow from a surface; the condition of a flow separated from the surface of a body and no longer following its contours.

flutter A vibration or oscillation of a control surface or wing created and maintained by aerodynamic forces and the elastic and inertial forces of the object itself.

force A vector quantity equal to the push or pull exerted on a body. By Newton's Second Law, a force is a function of an acceleration and the mass of the body.

form drag Drag resulting from airflow over a surface with some frontal area, often referred to as pressure drag, profile drag, or plate drag.

fowler flap A high lift device that consists of a sliding airfoil attached to the trailing edge of a wing that increases camber, wing area, and uses BLC to increase the C_L .

friction Resistance due to the rubbing of one body or substance against another. Air friction results from the viscosity of the air, or its tendency to stick to a surface.

friction drag Drag arising from friction forces at the surface of an aircraft, due to the viscosity of the air.

fuel flow The rate of fuel being consumed by an aircraft's engine.

fuselage The main structural component of an airplane.

full-cantilever Supported at one point only, as in a full-cantilever wing, or a wing that is entirely internally supported, with no external bracing.

G (gravitational acceleration) A constant, equal to 32.2 ft/sec^2 , representing the acceleration on an object due to the Earth's gravity.

General Gas Law $P = \rho R T$. Law of physics that shows the relationship between properties of air: pressure (P), density (ρ), and temperature (T). R is a constant for any given mixture of gases (such as dry air).

geometric twist Form of wing tailoring that employs a decrease in the angle of incidence from the wing root to the wingtip. The wing root has a higher angle of incidence than the wingtip, causing it to stall first.

glide A shallow descent, usually associated with power off flight.

glide endurance (GE) The maximum time that an airplane can stay airborne in a glide as a function of weight, altitude, and angle of attack.

glide range (GR) The maximum distance that can be traveled in a glide as a function of altitude, wind, and lift to drag ratio.

glide ratio The ratio of the horizontal distance traveled to the vertical distance descended in a glide. Glide ratio is equal to the lift to drag ratio.

gross weight The total weight of a fully loaded aircraft.

ground effect The dramatic reduction of induced drag and thrust required that occurs within one wingspan of the ground or other surface.

ground speed (GS) An airplane's actual speed over the ground.

gust A sudden and brief change of wind speed or direction.

gust load A load imposed upon an aircraft or aircraft member by a gust.

gyroscopic precession The resultant action or deflection of a spinning disc when a force is applied parallel to its axis. The resultant force occurs 90° ahead in the direction of rotation, and in the direction of the applied force.

headwind A wind blowing from directly ahead, or blowing from a forward direction such that its principal effect is to reduce ground speed.

helicopter A rotorcraft that, for its horizontal motion, depends principally on its engine driven rotors.

high lift device Any device, such as a flap, or boundary layer control device, used to increase the lift of a wing by increasing the C_L or area of the wing. The result is a reduction of takeoff and landing speeds. Increases in C_L are achieved by increasing the camber of an airfoil, or by controlling the kinetic energy in the boundary layer.

hinge line The transverse axis around which a control surface moves.

horizontal stabilizer The entire horizontal part of an airplane's empennage comprising both fixed and movable surfaces. On most airplanes, the horizontal stabilizer is the greatest contributor to longitudinal stability.

horsepower A unit of power equal to 550 ft-lbs/sec or 33,000 ft-lbs/min.

humidity The amount of water vapor in the air.

hypersonic Movement or flow at very high supersonic speeds, generally at a Mach number of 5 or greater.

indicated airspeed (IAS) The instrument indication for the amount of dynamic pressure that the aircraft is creating during some given flight condition. Indicated airspeed is displayed in knots, abbreviated KIAS.

indicated altitude The indication on a pressure altimeter when the Kollsman window is set to the current local altimeter setting.

induced drag (D_i) That portion of total drag resulting from the production of lift.

infinite wing A wing with no wingtips; used in discussing airflow around an airfoil in ideal situations.

interference drag Drag caused by the mixing of streamlines around aircraft components due to their proximity. It is a form of parasite drag.

inverted spin A spin characterized by negative Gs and an inverted attitude.

isothermal layer The layer of the atmosphere from approximately 36,000 through 66,000 feet, in which the air remains at a constant temperature of -56.5°C .

kinetic energy (KE) The ability of a body to do work because of its motion.

laminar flow The portion of the boundary layer airflow that is smooth and unbroken and travels along well defined streamlines.

laminar flow wing An airfoil specially designed to maintain a laminar flow boundary layer.

lateral axis An axis going through an airplane's center of gravity from side to side (wingtip to wingtip). Any movement developed around this axis is called pitch.

lateral control Control of the lateral axis around the longitudinal axis; roll control.

lateral moment A moment created around an airplane's longitudinal axis.

lateral stability The stability of an aircraft around its longitudinal axis. The reaction of an aircraft to an angle of bank.

leading edge flaps A high lift device consisting of a hinged portion of the leading edge of a wing that moves down to increase the wing's camber.

leading edge radius The radius of a circle tangent to the leading edge, upper and lower surfaces of the airfoil.

lift (L) The component of the aerodynamic force acting perpendicular to the relative wind.

lift to drag ratio (L/D) The ratio of lift to drag, obtained by dividing the coefficient of lift by the coefficient of drag. A measure of the wing's efficiency. The L/D ratio is also used as the glide ratio.

lift to drag ratio-maximum (L/D_{MAX}) The greatest ratio of lift to drag. L/D_{MAX} AOA is the most efficient AOA for that airfoil.

limit airspeed See redline airspeed.

limit load The maximum load factor an airplane can sustain without any possibility of permanent deformation. It is the maximum load factor anticipated in the normal operation of the airplane.

linear acceleration Acceleration along a line or axis.

load A stress-producing force.

load factor (n) The ratio of the load applied by an airplane's lift to the load applied by its weight. It is a multiple of the acceleration of gravity, commonly called "Gs."

local speed of sound The speed at which sound travels in a given medium under local ambient conditions.

longitudinal axis An axis extending from the nose to the tail of an aircraft, passing through its center of gravity. Any movement developed around this axis is called roll.

longitudinal control Control of the longitudinal axis around the lateral axis; pitch control.

longitudinal moment A moment created around an airplane's lateral axis.

longitudinal stability The stability of an aircraft around the lateral axis. The reaction of an aircraft to changes in pitch.

Mach number (M) (Pronounced "mock," after Ernest Mach (1838-1916), Austrian scientist.) The ratio of the true airspeed of an object moving through the air to the local speed of sound in that air.

maneuverability The ability of an airplane to readily alter its flightpath. The ease with which an airplane moves out of equilibrium.

maneuver point The point on the V-n diagram at the intersection of the positive accelerated stall line and the positive limit load. It is the point where the limit load may be achieved without the possibility of overstress, or the lowest airspeed that the limit load is encountered.

maneuver speed (V_a) The indicated airspeed that an airplane can achieve its maximum turn rate and minimum turn radius. The slowest velocity that an airplane can generate its limit load. It is usually the recommended turbulent air penetration airspeed.

mass (m) The quantity of molecular material that comprises an object.

mass balance The feature of a control surface that reduces the magnitude of the inertial and gravitational moments around the hinge line.

mean aerodynamic chord (MAC) The chord of an imaginary rectangular airfoil that would have pitching moments throughout the flight range the same as those of an actual airfoil.

mean camber line A line halfway between the upper and lower surface of an airfoil.

minimum glide angle The smallest angle between the horizon and the flightpath of an airplane in a glide.

moment A tendency to cause rotation around a point or axis, as a control surface around its hinge or an airplane around its center of gravity; the measure of this tendency, equal to the product of the force and perpendicular distance between the point of rotation and the direction of the force., expressed as a vector. Also called torque.

moment arm The distance from a point of rotation, perpendicular to the force, over which a force acts to create a moment.

monocoque A type of construction, as an airplane fuselage, in which most or all the stresses are carried by the covering or skin.

nacelle A streamlined structure or compartment on an aircraft, used as housing for an engine.

negative camber airfoil An airfoil in which the mean camber line is below the chord line.

neutral point (NP) The location of the center of gravity of an airplane that would produce neutral longitudinal static stability. The average aerodynamic center for the overall airplane.

Newton's First Law (The Law of Equilibrium.)
"A body at rest tends to remain at rest and a body in motion tends to remain in motion in a straight line at a constant velocity unless acted upon by some unbalanced force."

Newton's Second Law (The Law of Acceleration.) "The acceleration of a body is directly proportional to the force exerted on the body, is inversely proportional to the mass of the body, and is in the same direction as the force." $F = m a$.

Newton's Third Law (The Law of Interaction.)
"For every action, there is an equal and opposite reaction."

nosewheel liftoff / touchdown speed (NWLO/)
The lowest speed that a heading and course along the runway can be maintained with full rudder and ailerons deflected when the nosewheel is off the runway.

overstress The condition of possible permanent deformation or damage that results from exceeding the limit load. It also refers to the damage that may occur as a result of exceeding the limit load. Overstress damage will not cause structural failure of the airframe, but could result in internal damage to various components.

parasite drag (D_p) All drag not associated with the production of lift.

phugoid oscillations Oscillations of altitude and airspeed that occur over relatively long periods of time, and are easily controlled by the pilot. Also called phugoid motion.

pilot induced oscillations (PIO) Oscillations of attitude and angle of attack caused by the pilot trying to stop unwanted aircraft oscillations, or by the instability of the control surfaces. These inputs may result in an increase in the magnitude of the original oscillations.

pitch The motion of an aircraft around its lateral axis. Pitch control is achieved through use of elevators or stabilators.

pitch angle The angle between the chord line of the rotor blade and the rotor's tip path plane; the angle between the propeller blade and the propeller tip path plane.

pitch attitude (θ) The angle between the longitudinal axis of the airplane and the horizon.

pitching moment Any moment around the lateral axis of an airplane.

pitot static system A system consisting of a pitot tube, a static pressure port, and a device that determines the difference, used principally in order to calculate dynamic pressure.

plain flap A high lift device consisting of a hinged airfoil attached to the leading or trailing edge of a wing that increases camber to increase the C_L .

planform The outline of an object, such as a wing, as viewed from above.

positive camber airfoil An airfoil in which the mean camber line is above the chord line.

potential energy (PE) The ability of a body to do work because of its position or physical state.

power (P) The rate of doing work, or work per unit time, measured in ft-lbs/sec or horsepower.

power available (P_A) The power an engine is producing. Power available is a function of PCL setting, density altitude, and velocity.

power control lever (PCL) Control on a propeller driven airplane or helicopter, that adjusts the fuel flow and therefore the power output of the engine(s). Similar to the throttle on a jet aircraft.

power deficit (P_D) The negative difference between power available and power required.

power excess (P_E) The positive difference between power available and power required.

power required (P_R) The power required to produce enough thrust to overcome drag in level equilibrium flight.

pressure altimeter Aneroid barometers calibrated to indicate altitude in feet instead of pressure.

pressure altitude (PA) Height above the standard datum plane, i.e., altitude measured from standard sea level pressure by a barometric altimeter.

pressure gradient A change in the pressure of a fluid per unit of distance.

propeller efficiency (p.e.) A measure of the effectiveness of a propeller in converting shaft horsepower into thrust horsepower.

Propeller wash The disturbed air produced by the passage of the propeller, usually making a corkscrew path around the airplane.

pullout An act or instance of recovering from a dive.

radar altimeter Specialized radar transmitter/receiver used to indicate height above terrain.

radius of turn (r) See turn radius.

range The distance that an aircraft can travel without refueling.

rate of climb (ROC) The rate at which an aircraft gains altitude, the vertical component of its airspeed in a climb.

rate of descent (ROD) The rate at which an aircraft loses altitude, the vertical component of its airspeed in a descent. Also called sink rate.

rate of turn (ω) See turn rate.

redline airspeed (V_{NE}) The maximum permissible airspeed for an airplane. Beyond the redline airspeed, a pilot may experience control problems and structural damage to the aircraft due to aeroelastic effects.

region of normal command The region of flight at velocities greater than maximum endurance airspeed in which an airplane is in stable equilibrium. That is, if disturbed (slowed down), it tends to return to equilibrium.

region of reversed command The region of flight at velocities less than maximum endurance airspeed, in which a greater power setting is required to fly at a lower velocity, due to increased total drag caused by induced drag. Takeoff and landing normally take place while in this region. Also called the “back side of the power curve.”

relative wind (RW) The airflow experienced by the aircraft as it flies through the air. It is always equal and opposite to the flightpath. The relative wind may arise from the motion of the body, from the motion of the air, or from both.

reverse thrust Thrust applied to a moving object in a direction opposite to the direction of the object’s motion.

reversibility The ability to transmit aerodynamic forces from the control surfaces to the cockpit controls.

roll The motion of an airplane around its longitudinal axis. Roll is controlled by the use of ailerons or spoilers.

rudder An upright control surface that is deflected to produce a yawing moment, rotating the airplane around its vertical axis.

safe flight envelope The portion of the V-n diagram that is bounded on the left by the accelerated stall lines, on the top and bottom by the positive and negative limit loads, and on the right by redline airspeed. An aircraft may operate in its safe flight envelope without exceeding its structural or aerodynamic limits.

scalar A quantity expressing only magnitude, e.g., time, amount of money, volume of a body.

section A cross section of an airfoil taken at right angles to the span axis or some other specified axis of the airfoil.

semi-monocoque A type of construction, as of a fuselage or nacelle, in which transverse members and stringers reinforce the skin and help carry the stresses.

shaft horsepower The horsepower delivered at the rotating driveshaft of an engine.

shielded horn The part of a control surface of longer chord than the rest of the surface, lying forward of the hinge line and partially shielded by the surface to which it is attached, used for aerodynamic balance.

shockwave A surface or sheet of discontinuity set up in a supersonic field of flow, through which the fluid undergoes a finite decrease in velocity accompanied by a marked increase in pressure, density, temperature, and energy.

sideslip A movement of an airplane such that the relative wind has a component parallel to the lateral axis.

sideslip angle (β) The angle between the airplane’s longitudinal axis and the relative wind, as seen from above.

sideslip relative wind The component of the relative wind that is parallel to the airplane's lateral axis.

sine (sin) In a right triangle, the function of an acute angle that is the ratio of the length of the opposite side to the length of the hypotenuse.

sink rate See rate of descent.

skin friction The friction of a fluid against the skin of an aircraft or other body; friction drag.

slat The vane used in a slot, especially an automatic slot. When the slat deploys it forms a slot.

slot High lift device that consists of a fixed vane that forms a gap between the leading edge of the wing and the body of the wing that allows airflow from below the wing to reach the upper surface and reenergize the boundary layer, delaying boundary layer separation. Also called fixed slot.

slotted flap A high lift device consisting of a hinged airfoil attached to the leading or trailing edge of a wing that increases camber and uses BLC to increase the C_L .

sonic Pertaining to sound or the speed of sound.

sonic boom An explosion-like sound heard when a shock wave generated by a supersonic airplane reaches the ear.

sonic speed Speed equal to the speed of sound.

sound barrier A popular term for the large increase in drag that acts upon an aircraft approaching the speed of sound.

span See wingspan.

spanwise flow Airflow that travels the span of the wing, parallel to the leading edge, normally root to tip. This airflow is not accelerated over the wing and therefore produces no pressure differential or lift.

spar A principal spanwise beam in the structure of a wing.

speed of sound The speed at which sound travels in a given medium under certain conditions. The speed of sound in air is primarily dependent on the temperature of the air mass.

spin An asymmetrical aggravated stall resulting in autorotation.

spiral A maneuver in which an airplane ascends or descends in a helical (corkscrew) path at an angle of attack within the normal range of flight angles.

spiral divergence A motion resembling a spiraling descent, becoming steeper over time. Spiral divergence results from strong static directional stability and weak static lateral stability.

split flap A high lift device consisting of a plate deflected from the lower surface of the trailing edge of a wing that increases camber to increase the C_L . It produces a similar change in C_L as a plain flap, but a much larger increase in drag due to the great turbulent wake produced.

spoiler A movable control surface attached to the wing of an airplane, used to produce a rolling moment around the longitudinal axis by disturbing the flow of the boundary layer over one wing.

stabilator A movable control surface that replaces the horizontal stabilizer and elevators.

stability The property of a body, such as an aircraft, to maintain its attitude or to resist displacement, and if displaced, to develop forces and moments that would return it to its original condition.

stabilizer A fixed or adjustable airfoil or vane that provides stability for an aircraft, i.e., a fin, the horizontal or vertical stabilizer on an airplane.

stagnation Loss of kinetic energy or velocity. Lack of motion.

stall A condition of flight in which an increase in AOA will result in a decrease in C_L .

stall fence A plate or vane projecting from the upper surface of a wing, parallel to the airstream, used to prevent spanwise flow.

stalling angle of attack The angle of attack on an airfoil beyond which a stall occurs, i.e., $C_{L_{MAX}}$. Beyond this angle of attack, the boundary layer is unable to remain attached to the wing, resulting in the decrease in C_L .

stall speed (V_S) The minimum true airspeed required to maintain level flight at $C_{L_{MAX}}$ AOA.

stall strip A sharply angled device attached near the wing's root on its leading edge to initiate a root first stall.

standard atmosphere A reference set of average atmospheric conditions.

standard datum plane (SDP) The actual elevation at which the barometric pressure is 29.92 in. Hg.

standard rate turn (SRT) A turn in an aircraft with a three degree per second turn rate.

static failure The breaking (or serious permanent deformation) of a material due to a steadily increasing, or sudden large application of force. This type of failure is often immediate and can occur without warning.

static pressure (P_s) The weight of a column of air over a given area; the pressure each air particle exerts on another due to the weight of all the particles above; the potential energy per unit volume.

static stability The initial tendency of an object to either move toward or away from equilibrium after a disturbance.

static strength A measure of a material's resistance to a steadily increasing load or force.

steady airflow Airflow in which at every point in the moving air mass, the pressure, density, temperature and velocity are constant.

stiffness Resistance to deflection or deformation.

straight horn See unshielded horn.

streamline The path traced by a particle of air while in steady flow.

streamtube An impenetrable tube formed by many streamlines. Streamtubes are closed systems.

strength A measure of a material's resistance to load or force.

subsonic Movement or flow at speeds below the speed of sound, generally at a Mach number of 0.0 to 0.75.

supersonic Movement or flow at speeds above the speed of sound, generally at a Mach number of 1.2 to 5.0.

sweep angle (Λ) The angle between the lateral axis and a line drawn 25% aft of the leading edge.

symmetric Exhibiting a correspondence of parts on opposite sides of a boundary or axis

symmetric airfoil An airfoil in which the mean camber line is coincident with the chord line. Also called a zero camber airfoil.

tangent (tan) In a right triangle, the function of an acute angle that is the ratio of the length of the opposite side to the length of the adjacent side. A line, curve, or surface touching but not intersecting another line, curve or surface at only one point.

taper A gradual reduction in the chord length of an airfoil from root to tip.

taper ratio (λ) The ratio of tip chord to root chord. The taper ratio affects the lift distribution and the structural weight of the wing.

temperature A measure of the average kinetic energy of air particles, expressed in degrees Celsius ($^{\circ}\text{C}$), Fahrenheit ($^{\circ}\text{F}$), or Kelvin (K).

terminal velocity The maximum velocity an airplane can attain under given conditions. A vertical (zero-lift) dive path, normal gross weight, zero engine thrust, and standard sea-level air density are assumed.

thickness The cross sectional height of an airfoil measured perpendicular to the chord line.

thrust available (T_A) The thrust an engine produces under a specific velocity, density, and throttle setting.

thrust axis The axis along which thrust is produced and the direction in which the force is generated.

thrust deficit (T_D) The negative difference between thrust available and thrust required.

thrust excess (T_E) The positive difference between thrust available and thrust required.

thrust horsepower The actual amount of horsepower that an engine-propeller system transforms into thrust, equal to shaft horsepower multiplied by propeller efficiency.

thrust required (T_R) The thrust required to overcome drag to maintain level equilibrium flight.

total pressure The pressure a moving fluid would have if it were brought to a rest without losses.

transonic Movement or flow at speeds very near the speed of sound, generally at a Mach number of 0.75 to 1.2.

trimmed flight A condition that exists when the sum of the moments acting around the center of gravity are equal to zero. The word "trim" often refers to the balance of control forces.

trim tab A tab that is deflected to a position where it remains to keep the aircraft in the desired attitude.

true airspeed (TAS) The velocity of an aircraft with respect to the air mass in which it is traveling. Airspeed value determined by correcting indicated airspeed for installation error, compressibility, and density.

true altitude The actual height above mean sea level. It is found by correcting calibrated altitude for temperature deviations from the standard atmosphere.

turbulence An agitated condition of air in which random fluctuations in velocity and direction occur. Airflow in which the velocity at any point varies erratically in magnitude and direction.

turbulent flow Boundary layer airflow characterized by turbulent, unsteady airflow.

turn radius (r) One half the diameter of the circle an aircraft would fly if it completed a 360 degree turn.

turn rate (ω) The number of degrees of arc traversed per unit of time while turning, expressed in degrees/sec.

ultimate load The maximum load factor that the airplane can withstand without structural failure. It is 1.5 times the limit load.

unshielded horn The part of a control surface of longer chord than the rest of the surface, lying forward of the hinge line and entirely exposed to the relative wind, used for aerodynamic balance.

upwash Chordwise airflow from the lower surface of an airfoil passing upward over the leading edge to the upper surface. Any upward airflow.

V-n diagram A diagram describing the structural and aerodynamic limits within which an airplane must operate.

vector A quantity that expresses both magnitude and direction. A vector quantity is represented by an arrow that displays direction and has a length proportional to magnitude.

velocity (V) Speed, as referenced to another plane, object, or system. A vector quantity equal to speed in a given direction. True airspeed.

velocity never-to-exceed (V_{NE}) See redline airspeed.

vertical axis An axis passing from top to bottom through the aircraft's center of gravity. Any movement developed around this axis is called yaw.

vertical stabilizer A fin mounted approximately parallel to the plane of symmetry of an airplane, to which the rudder is attached.

viscosity (μ) A measure of a fluid's resistance to flow and shearing.

volume The size of the mass, or the amount of space occupied by an object.

vortices / wingtip vortices A spiraling mass of air created at the wingtip, due to the airflow around the tip from the high-pressure region below the surface to the low-pressure region above it. Vortex strength is dependent upon the wing loading, gross weight, and speed of the generating airplane. Vortices from medium to heavy airplanes can be extremely hazardous to smaller airplanes. Also called wake turbulence, or jetwash.

weight The force at which a mass is attracted toward the center of the earth by gravity.

wing An airfoil that produces a pressure differential when air is forced over it, resulting in a lifting force.

wing area (S) The surface area of a wing from wingtip to wingtip. The area within the outline of a projection of a wing on the plane of its chord, including that area lying within the fuselage or nacelles. With a swept wing, the area within the fuselage is contained within lines having the same sweep angle as the leading and trailing edges, fairings or fillets being ignored.

wing loading (WL) A ratio of airplane weight to the wing surface area.

wing root The base of a wing, where it joins the fuselage or other main body of an airplane.

wing section A cross section of a wing; the profile of a cross section or the area defined by a profile.

wingspan (b) The length of a wing, measured from wingtip to wingtip. Also called span.

work (W) Work is done when a force acts on a body and it moves. Work is a scalar quantity measured in ft-lbs. $W = F \times s$

yaw Rotation around the vertical axis of an airplane. Yaw is controlled by the rudder.

Useful Equations

$$W = F \cdot s$$

$$F = ma$$

$$M = F \times d$$

$$TE = PE + KE$$

$$PE = mgh$$

$$WL = \frac{W}{S}$$

$$KE = \frac{1}{2} mV^2$$

$$P = \rho RT$$

$$S = bc$$

$$\lambda = \frac{C_T}{C_R}$$

$$AR = \frac{b}{c}$$

$$\rho_1 A_1 V_1 = \rho_2 A_2 V_2$$

$$P_T = P_S + q$$

$$q = \frac{1}{2} \rho V^2$$

$$M = \frac{TAS}{LSOS}$$

$$TAS = IAS \sqrt{\frac{\rho_0}{\rho}}$$

$$AF = \frac{1}{2} \rho V^2 SC_{AF}$$

$$L = \frac{1}{2} \rho V^2 SC_L$$

$$V_S = \sqrt{\frac{2W}{\rho SC_{Lmax}}}$$

$$IAS_S = \sqrt{\frac{2W}{\rho_0 SC_{Lmax}}}$$

$$D = \frac{1}{2} \rho V^2 SC_D$$

$$D_T = D_P + D_I$$

$$D_P = qf$$

$$D_I = \frac{kL^2}{\rho V^2 b^2}$$

$$P_R = \frac{T_R \cdot V}{325}$$

$$P_A = \frac{T_A \cdot V}{325}$$

$$THP = SHP \cdot p.e.$$

$$T_E = T_A - T_R$$

$$P_E = P_A - P_R$$

$$\sin \gamma = \frac{T_E}{W}$$

$$ROC = \frac{P_E}{W}$$

$$ROD = \frac{P_D}{W}$$

$$n = \frac{L}{W}$$

$$V_{S\phi} = \sqrt{\frac{2Wn}{\rho SC_{Lmax}}}$$

$$IAS_{S\phi} = \sqrt{\frac{2Wn}{\rho_0 SC_{Lmax}}}$$

$$\omega = \frac{g \tan \phi}{V}$$

$$r = \frac{V^2}{g \tan \phi}$$

$$V_{TO} \approx 1.2 \sqrt{\frac{2W}{\rho SC_{Lmax}}}$$

$$IAS_{TO} \approx 1.2 \sqrt{\frac{2W}{\rho_0 SC_{Lmax}}}$$

$$V_{LDG} \approx 1.3 \sqrt{\frac{2W}{\rho SC_{Lmax}}}$$

$$IAS_{LDG} \approx 1.3 \sqrt{\frac{2W}{\rho_0 SC_{Lmax}}}$$

$$F_R = \mu(W - L)$$

$$S_{TO} = \frac{W^2}{g \rho SC_{Lmax} (T - D - F_R)}$$

$$S_{LDG} = \frac{W^2}{g \rho SC_{Lmax} (F_R + D - T)}$$

$$V_{hydroplane} = 9 \sqrt{\text{tire pressure}}$$

Standard Day Conditions

Altitude (feet)	Temperature		LSOS (knots)	Pressure (in. Hg)	Density (g / L)
	°C	°F			
0	15.0	59.0	661.7	29.921	1.225
1,000	13.0	55.4	659.4	28.856	1.190
2,000	11.0	51.9	657.1	27.821	1.155
3,000	9.1	48.3	654.8	26.817	1.121
4,000	7.1	44.7	652.5	25.843	1.088
5,000	5.1	41.2	650.2	24.897	1.056
6,000	3.1	37.6	647.9	23.980	1.024
7,000	1.1	34.0	645.6	23.090	0.993
8,000	-0.8	30.5	643.2	22.228	0.963
9,000	-2.8	26.9	640.9	21.391	0.934
10,000	-4.8	23.4	638.5	20.581	0.905
11,000	-6.8	19.8	636.2	19.795	0.877
12,000	-8.8	16.2	633.8	19.035	0.849
13,000	-10.7	12.7	631.4	18.298	0.823
14,000	-12.7	9.1	629.1	17.584	0.797
15,000	-14.7	5.5	626.7	16.893	0.771
16,000	-16.7	2.0	624.3	16.225	0.746
17,000	-18.7	-1.6	621.8	15.578	0.722
18,000	-20.6	-5.1	619.4	14.952	0.698
19,000	-22.6	-8.7	617.0	14.346	0.676
20,000	-24.6	-12.3	614.6	13.761	0.653
25,000	-34.5	-30.0	602.2	11.118	0.550
30,000	-44.4	-47.8	589.6	8.903	0.459
35,000	-54.2	-65.6	576.8	7.060	0.380
36,000	-56.2	-69.2	574.1	6.732	0.366
40,000	-56.5	-69.7	573.7	5.558	0.303
45,000	-56.5	-69.7	573.7	4.375	0.238
50,000	-56.5	-69.7	573.7	3.444	0.188
55,000	-56.5	-69.7	573.7	2.712	0.148
60,000	-56.5	-69.7	573.7	2.135	0.116
65,000	-56.5	-69.7	573.7	1.682	0.092

T-6B Data

PHYSICAL CHARACTERISTICS

FUSELAGE:

Construction: Semi-monocoque, Length: 33 ft 4 in, Height: 10 ft 8 in at tail

LANDING GEAR:

Tricycle

WING:

Construction: Full cantilever, Wingspan: 33 ft 5 in, Flap type: Split

PROPELLER:

Type: Variable pitch, Rotation: clockwise, Prop arc: 8 ft 1 in

CONTROLS:

Type: conventional –reversible, trim –electric, with trim aid system for directional assisted trim

	Aerodynamic Balance	Artificial Feel
Aileron	Overhang	Neutral trim tabs
Rudder	Shielded Horn	Anti-servo trim tabs
Elevator	Shielded Horn	Bobweights, Downsprings, and neutral trim tabs

FLIGHT CHARACTERISTICS

C_{Lmax} AOA: 18 units

Stall warning: Buffet, stick shaker, AOA display on PFD/HUD, AOA indexers (one in each cockpit)

Spin indications:

	Erect	Inverted
Altimeter	Decreasing	Decreasing
AOA	18+ Units	0 Units
Airspeed	120–135 KIAS	40 KIAS
Turn Needle	Fully deflected	Fully deflected

Crosswind limits: 25 kts (Flaps UP or TO, and dry runway), 10 kts (Flaps LDG, or wet runway)

Redline airspeed: 316 KIAS, 0.67 MACH (>19,020' MSL), 150 KIAS (gear down and/or flaps down)

Maneuver airspeed: 227 KIAS, Maximum turbulence airspeed: 207 KIAS (recommended 180 KIAS)

Limit load factor: +7.0 Gs, –3.5 Gs; Gear down and/or Flaps down: +2.5 Gs, 0.0 G

Standard rate turn: 2 needle widths; AOB = 15–20% indicated airspeed

PERFORMANCE CHARACTERISTICS

Engine: PT6A-68, Sea level flat rated 1100 SHP (2900 ft-lbs torque)

Critical altitude: 16,000 ft

Operational ceiling: 31,000 ft

Max endurance is achieved at 125 KIAS and 8.8 units AOA

Max range is achieved at 4.4 units AOA (KIAS varies)

Max AOC is not used in the T-6B, max ROC airspeed / best climb speed: 140 KIAS

Max level airspeed: 255 KIAS, normal climb airspeed: 160 KIAS

Max glide range / best glide speed at 125 KIAS for 11:1 glide ratio

CONTRIBUTIONS TO STATIC STABILITY

Feature	Longitudinal	Directional	Lateral
Straight Wings	-	+	
Swept / Delta Wings	+	+	+
Fuselage	-	-	
Horizontal Stabilizer	++		
Neutral Point. aft of C.G.	+		
Vertical Stabilizer		++	+
Dihedral Wings			++
Anhedral Wings			--
High-Mounted Wings			+
Low Mounted Wings			-

Performance Study Guide

	Weight Increase	Altitude Increase	Gears Down	Flaps Down
T_A		↓		
T_R	→ ↑	→	↑	← ↑
T_E	↓	↓	↓	↓
P_A		↓		
P_R	→ ↑	→ ↑	↑	← ↑
P_E	↓	↓	↓	↓

Performance Characteristic	Goal	Curve Referenced & V vs L/D_{MAX}		Effect of Factors on Performance			
		Jet	Prop	Weight↑	Altitude↑	Tailwind↑	Gear↓/Flap↓
Endurance	Min Fuel Flow	Thrust, =	Power, <	↓	↑		↓
Range	Min Fuel Flow / Velocity	Thrust, >	Power, =	↓	↑	↑	↓
AOC	Max T_E	Thrust, =	Thrust, <	↓	↓	↓	↓
ROC	Max P_E	Power, >	Power, =	↓	↓		↓
Glide Endurance	Min P_D	Power, <	Power, <	↓	↑		↓
Glide Range	Min T_D	Thrust, =	Thrust, =		↑	↑	↓

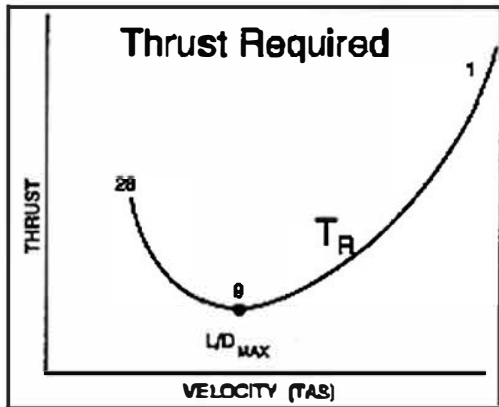

Figure 1

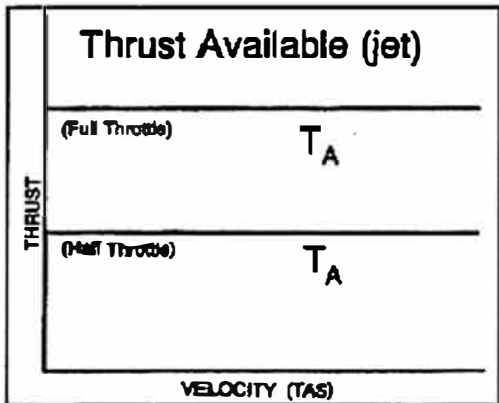

Figure 2

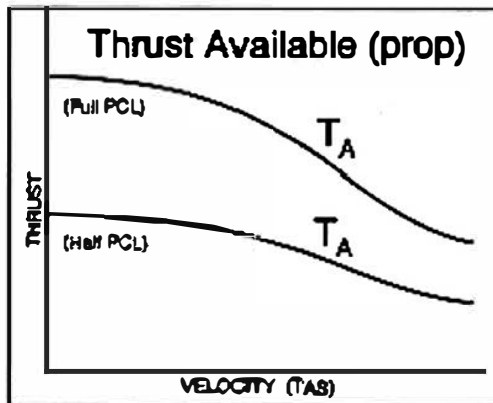

Figure 3

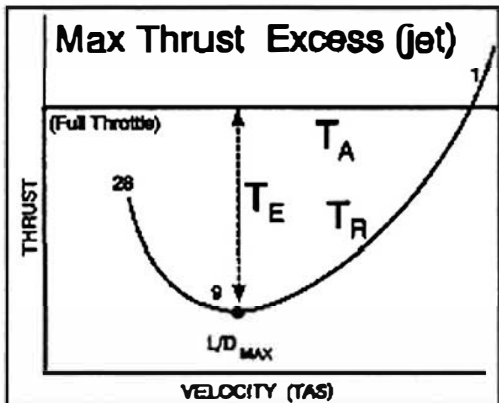

Figure 4

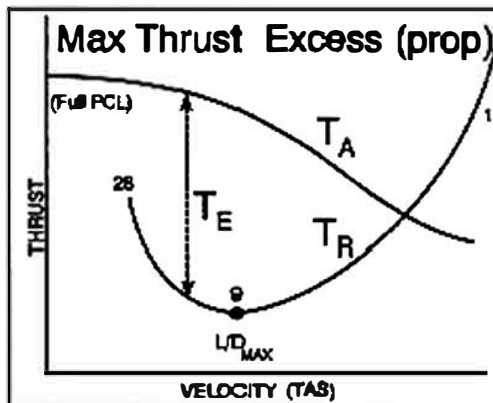

Figure 5

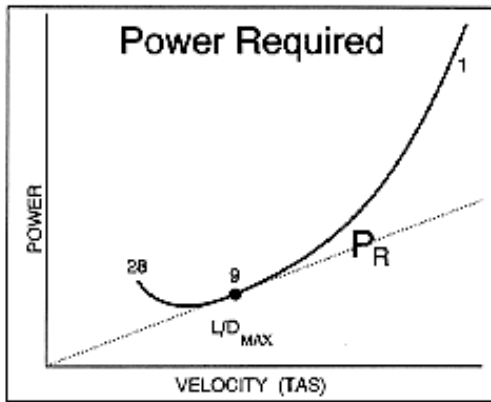

Figure 6

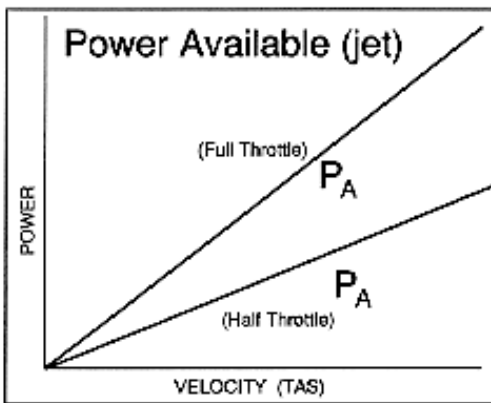

Figure 7

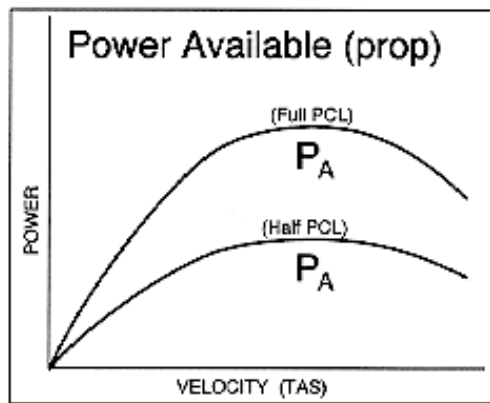

Figure 8

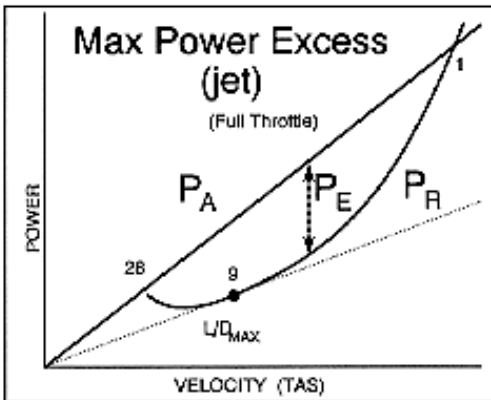

Figure 9

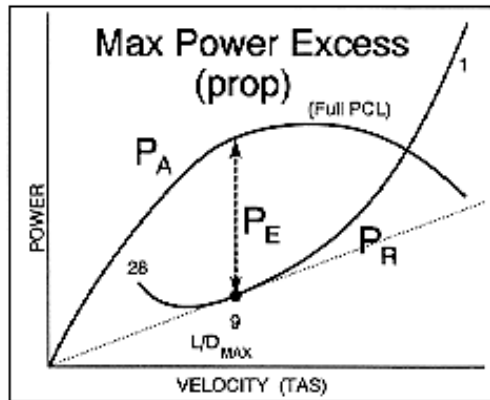

Figure 10

Symbols & Abbreviations

α	angle of attack	CAS	calibrated airspeed
β	sideslip angle	C_D	coefficient of drag
γ	climb or glide angle	C_{Di}	coefficient of induced drag
θ	pitch attitude	C_{Dp}	coefficient of parasite drag
λ	taper ratio	C_F	coefficient of aerodynamic force
Λ	sweep angle	CG	center of gravity
μ	viscosity or coefficient of friction	C_L	coefficient of lift
ρ	air density	C_{LMAX}	maximum coefficient of lift
ϕ	angle of bank	c_R	root chord
ω	rate of turn	c_T	tip chord
<	less than	d	moment arm distance
>	greater than	D	drag
\approx	approximately equal to	D	Density altitude
a	acceleration	D_i	induced drag
A	area	D_p	parasite drag
AC	aerodynamic center	D_T	total drag
AF	aerodynamic force	EAS	equivalent airspeed
AOA	angle of attack	f	equivalent parasite area
AOC	angle of climb	F	force
AR	aspect ratio	FF	fuel flow
b	wing span	F_R	rolling friction
c	average chord	G	acceleration of gravity
		GS	groundspeed

IAS	indicated airspeed	P_A	power available
IAS_{LDG}	indicated landing speed	P_D	power deficit
IAS_S	indicated stall speed	P_E	power excess
$IAS_{S\phi}$	indicated accelerated stall speed	P_R	power required
IAS_{SP}	indicated power-off stall speed	P_S	static pressure
IAS_{TO}	indicated takeoff speed	P_T	total pressure
k	constant	q	dynamic pressure
KE	kinetic energy	Q	torque
L/D	lift to drag ratio	r	radius of turn
L/D_{MAX}	maximum lift to drag ratio	ROC	rate of climb
L	lift	RW	relative wind
L_{EFF}	effective lift	s	distance of displacement
LSOS	local speed of sound	s_{LDG}	landing distance
m	mass	s_{TO}	takeoff distance
M	Mach number	S	wing surface area
M_{CRIT}	critical Mach number	SHP	shaft horsepower
n	load factor	SRT	standard rate turn
NP	neutral point	T	temperature or thrust
NWLO	nosewheel liftoff speed	T_A	thrust available
NWTD	nosewheel touchdown speed	T_D	thrust deficit
P	pressure		
p.e.	propeller efficiency		
PE	potential energy		
PA	pressure altitude		

Bibliography

Anderson, John D. Fundamentals of Aerodynamics, Fourth Edition. New York: McGraw Hill, 2007.

Anderson, John D., Introduction to Flight, Sixth Edition. New York: McGraw Hill, 2008.

Hurt, Hugh. Aerodynamics For Naval Aviators (NAVWEPS 00-80T-80). Washington D.C.: U.S. Government Printing Office, 1960.

National Oceanic and Atmospheric Administration. U.S. Standard Atmosphere, 1976, Washington, D.C.: U.S. Government Printing Office, 1976.

Naval Aviation Schools Command. Fundamentals of Aerodynamics. Center for Naval Aviation Technical Training, 2008.

Office of the Chief of Naval Operations. Flight Manual, NATOPS, USAF/USN Series T-6B Aircraft (NAVAIR A1-T6BAA-NFM-100). Commander, Naval Air Systems Command, 2012.

Talay, Theodore. Introduction to the Aerodynamics of Flight. Washington D.C.: Scientific and Technical Information Office, National Aeronautics and Space Administration, 1975.